

PAINTING ON THE MACINTOSH

A NON-ARTIST'S DRAWING GUIDE TO MACPAINT, SUPERPAINT, PIXELPAINT, HYPERCARD, AND MANY OTHERS

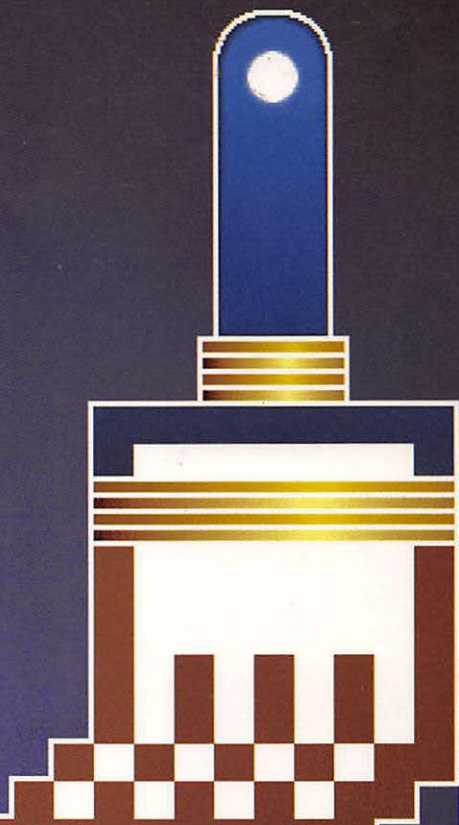

Deke McClelland
PUBLISHING RESOURCES INC.

Dow Jones-Irwin
Desktop Publishing Library



PAINTING ON THE MACINTOSH

*A non-artist's drawing guide
to MacPaint, SuperPaint,
PixelPaint, HyperCard, and many others*

PAINTING ON THE MACINTOSH

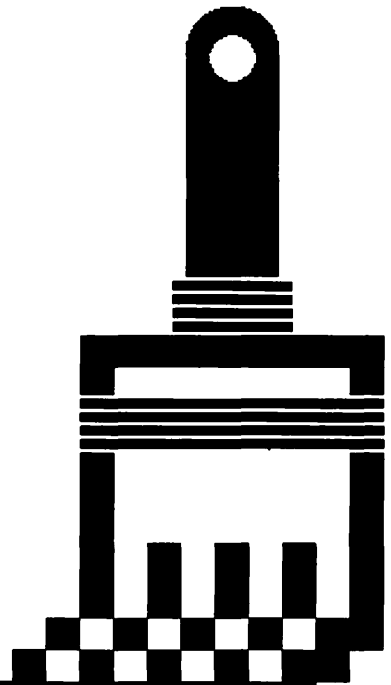

A NON-ARTIST'S DRAWING GUIDE TO MACPAINT, SUPERPAINT, PIXELPAINT, HYPERCARD, AND MANY OTHERS

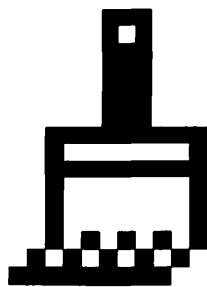
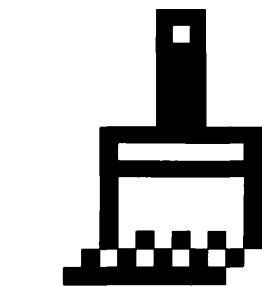
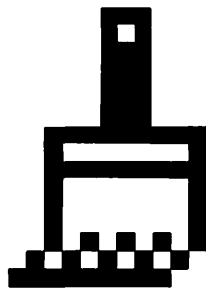
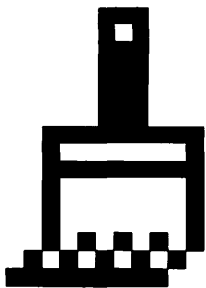

Deke McClelland
PUBLISHING RESOURCES INC.



Dow Jones-Irwin
Desktop Publishing Library

Dow-Jones Irwin, Homewood, IL 60430



© RICHARD D. IRWIN, INC., 1989

Dow Jones-Irwin is a trademark of Dow Jones & Company, Inc.

All rights reserved. No part of this publication may be reproduced, stored in a retrieval system, or transmitted, in any form or by any means, electronic, mechanical, photocopying, recording, or otherwise, without the prior written permission of the publisher.

This publication is designed to provide accurate and authoritative information in regard to the subject matter covered. It is sold with the understanding that the publisher is not engaged in rendering legal, accounting, or other professional service. If legal advice or other expert assistance is required, the services of a competent professional person should be sought.

From a Declaration of Principles jointly adopted by a Committee of the American Bar Association and a Committee of Publishers.

Library of Congress Cataloging-in-Publication Data

McClelland, Deke, 1962-

Painting on the Macintosh : a non-artist's drawing guide to MacPaint, SuperPaint, PixelPaint, HyperCard, and many others / Deke McClelland.

p. cm. — (Dow Jones-Irwin desktop publishing library)

Includes index.

ISBN 1-55623-265-9

1. Macintosh (Computer)—Programming. 2. Computer graphics—Computer programs. I. Title. II. Series.

QA76.8.M3M377 1989

89-7897

006.6'85—dc20

CIP

Printed in the United States of America

2 3 4 5 6 7 8 9 0 ML 6 5 4 3 2 1 0 9

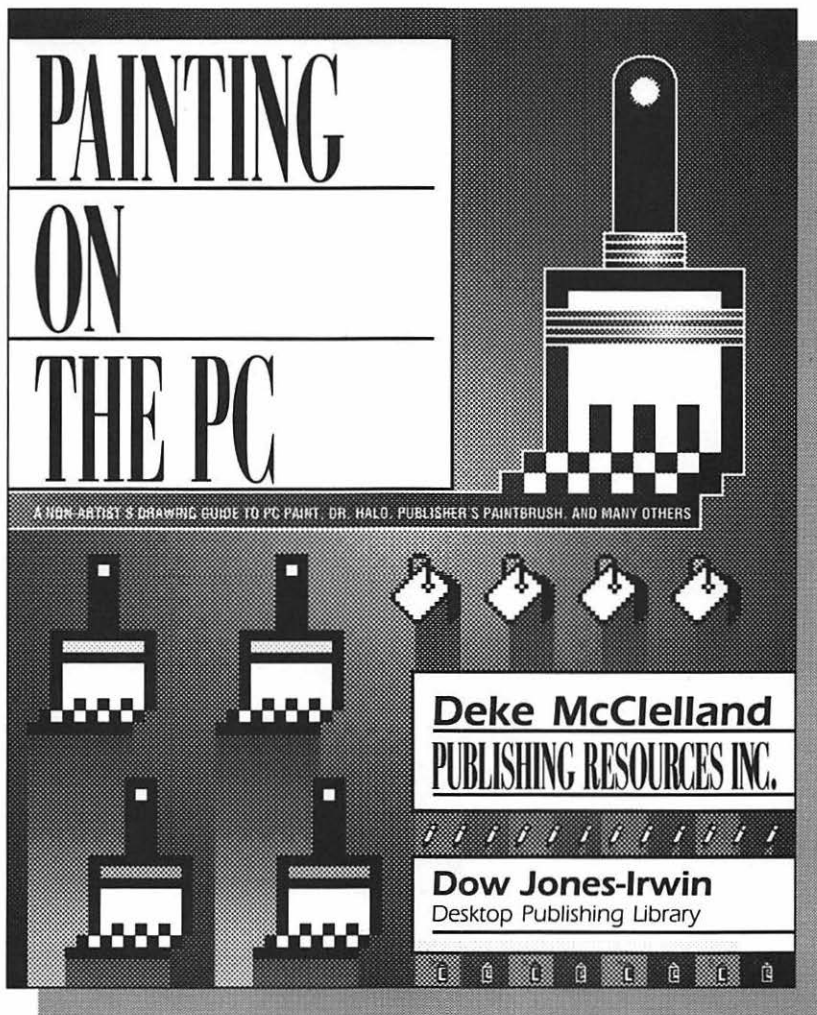

This title is also available in a PC-compatible edition.

Table of Contents

Foreword I

Part One, Developing a Successful Drawing Technique 5

Chapter 1: Understanding the Graphic Process7

Who can draw? 7

The electronic graphic process 9

Developing purpose and concept 10, *Sketching initial ideas* 12,

Creating a final draft 14, *Saving drawing for future reuse* 15

Examining drawing technique 17

Personal artistic style 20

Chapter 2: The Basics of Drawing Theory23

Presenting an idea professionally 26

Appropriateness: drawing for you audience 27, The importance of an appealing presentation 28, Creating appealing artwork 29

Drawing realistic forms 32

Recording form accurately 34, Stylizing form 36, Composition: the consistent flow of form 37

Scaling multiple objects 39

Indicating actual size differences 40, Distance: scaling between foreground and background 41, Scaling to indicate importance 43, Scaling for drama 45

Determining proportions 46

Accurately representing proportional differences 48, Making an object more interesting 49, Forcing visual relationships between objects 50

Demonstrating depth 51

Understanding perspective 52, Extending an object into the horizon 55, High detail and low focus 58, Shades of depth 59

Representing volume 61

Understanding origin of light 61, Shading and gradation 64, Reflection and reflected light 67

Adding color to your graphic 68

Understanding color models 68, Printing in color 70, Using like and contrasting colors 71, Color shading 72

Chapter 3: General Introduction to the Painting Environment75

The pencil and eraser tools 76

Drawing free-form lines and curves 77, Creating single dots 78, Erasing and undrawing mistakes 78, Drawing and erasing in straight lines 80, Sketching with the pencil 81

Line and shape tools and patterns 82

Creating a line or shape 83, The weight of a line or outline 85, Using gray values and patterns 88, Changing a gray value or pattern 90

Paintbrush, spraypaint, and paint can 93

Changing brush shapes 93, Painting with different patterns 96, Using the spraypaint tool 99, Spraypainting with a pattern 100, Filling solid and enclosed areas 101

The text tool and font commands	103
<i>The limitations of type in a paint program 103, Entering type from the keyboard 105, Determining font, style, size, spacing, and alignment 106</i>	
Lasso and marquee tools, basic commands	110
<i>Using the lasso tool 111, Using the marquee tool 114, Rotate, flip, and scale 115, Tracing edges 118, Fill and invert 119, Advanced special effects 122, Cut, copy, and paste 124, Cloning and drawing with an element 126</i>	
View sizes and the grabber tool	129
<i>Zooming, using the pencil in fat-bits 130, Moving the graphic with respect to the window 132</i>	

Chapter 4: Hints, Tips, & Painting Secrets 133

Thickening a line	134
<i>The lasso-and-clone method 134, The trace-edges-and-fill method 135</i>	
Adding a custom interior to a shape	136
<i>The cookie-cutter method 137</i>	
Type effects	141
<i>Changing letter spacing 142, Filling text with a pattern 143, Adding a custom interior to type 145</i>	
Creating and using gradations	148
<i>The spraypaint-layering method 149, The custom-gray-value method 151, Painting with custom gray values 155</i>	
Adding a shadow to an image	157
<i>The fill-scale-and-skew method 157</i>	

Part Two, Drawing from Scratch

Chapter 5: Basic Hands-On Projects 165

Creating a page ornament	166
Creating a simple cartoon	179

Chapter 6: Intermediate Hands-On Projects 195

Creating a human silhouette	196
Creating a company logo	210

Chapter 7: An advanced Hands-On Project 223

Creating a voluminous object	224
------------------------------	-----

Chapter 8: Creating Illustrations Using Clip-Art243

Customizing clip-art	246
<i>Simple clip-art transformations</i>	247, <i>Modification hints and tips</i>
248	
Combining multiple clip-art images	250
<i>Determining similar clip-art styles</i>	250, <i>Positioning multiple images to interact</i>
255	
Inserting clip-art into original drawings	257
<i>Finding clip-art similar to your personal style</i>	257, <i>Modifying your style to match clip-art</i>
259	
Framing your work with clip-art	261

Chapter 9: Using Scanned Artwork & Photographs ..265

<i>Scan formats and paint application compatibility</i>	267
Cleaning up scanned images	269
<i>Refining and enhancing artwork scans</i>	269, <i>Refining and enhancing photographic scans</i>
272	

Part Four, Comprehensive Software Review

Chapter 10: Paint Applications on the Macintosh281

<i>Unfamiliar terminology</i>	283
Canvas	284
Cricket Paint	287
DeskPaint	290
FullPaint	292
GraphicWorks	294
GraphistPaint II	296
HyperCard	299
LaserPaint Color II	301
MacPaint	304
Modern Artist	306
NuPaint	309
Photon Paint	311
PixelPaint	314
Studio/8	317
SuperPaint	320

Clip-Art Listing 325

Pages featuring clip-art images 326

Clip-art package vendors 328

Vendor information 329

Index 331

A 331, B 332, C 333, D 335, E 336, F 337, G 338, H 338,

I 338, J 339, K 339, L 339, M 339, N 340, O 341, P 341,

Q 343, R 343, S 343, T 346, U 347, V 347, W 347, Y 347,

Z 347

PAINTING ON THE MACINTOSH

*A non-artist's drawing guide
to MacPaint, SuperPaint,
PixelPaint, HyperCard, and many others*

Foreword

Craig Danuloff
President
Publishing Resources Inc.

It is often said that our world is becoming more and more the domain of the specialist. As each category of human interest and endeavor becomes increasingly complex and competitive, practitioners are left with little choice but to forgo a wide range of expertise in order to develop and maintain their chosen specialization. Time does not allow, or so the theory goes, one person to be an accountant and a researcher and an artist.

On the other hand, think of all that you can do with the aid of your personal computer and some software. If you have a spell-checking program,

you can spell; if you have an accounting package, you can correctly perform double-entry bookkeeping; if you have a telecommunications program, you can communicate with millions of people or search vast databases; and if you have page composition software, you can electronically “paste-up” complex documents. It seems that the personal computer is the anecdote to specialization.

In each of these cases, a complex process has been simplified to little more than data entry and button pushing. The tools required to perform these tasks have been computerized and the use of these tools has been automated.

The process of drawing, however, has thus far not undergone such a complete transformation. While the tools of drawing have been computerized—pencils, paintbrushes, and spraypaint cans are now simulated on-screen—the use of these tools has not been automated. This represents a fundamental difference between drawing and most other computerized processes: Drawing still requires that a person know how to use “the tools of the trade.”

But how many of us know how to use the tools of the drawing trade? Certainly not the average computer user—or so they believe. Millions of people own drawing software but most don’t dare to draw more than a map to their house. They assume that the ability to draw is solely dependent on talent, or that it requires extensive study and practice.

This book is for those people.

This book demystifies the artistic process, demonstrating that by learning a few basic principles, understanding the power of your automated drawing tools, and remembering where the “Undo” command is located, almost anyone can create the kind of art they need to spruce up newsletters, reports, letters, brochures, and so on. With a little practice, you will be creating original art as easily as you already correct your spelling, balance your books, or layout the monthly newsletter. In no time you will be personalizing your work, making it more attractive, saving both time and money, and having a little more fun with your computer.



A few words of advice before you set off to become the complete Renaissance Man or Woman: Start simple, stick with it, and refer back to the elementary sections of this book often. Drawing isn't going to be quite as easy as running your spell-checker (although it may be easier than balancing your books). And don't be embarrassed by your early work; just claim that it's some horrible clip-art you are trying to fix.

Best of luck.

Part 1

Developing a Successful Drawing Technique



Understanding the Graphic Process

An effective graphic is an amazing thing. To the untrained eye, it may be as mysterious as it is pleasing, seemingly outside the realm of personal achievement. But like a piece of furniture or a loaf of bread, an illustration is a basic work of craftsmanship. In this chapter, we try to break down the craft of drawing into its two basic elements of process and technique. By examining how an artist works and what an artist knows, we may gain a clearer understanding of how to create a successful graphic.

Who can draw?

A common misconception among “non-artists” is that drawing is a talent that is not so much learned as inherited at birth. In fact, most people can learn to draw passably, even quite well, in a short period of time.

*It is possible to
learn to draw
passably, even quite
well, in a short
period of time.*

Developing an ability to draw is not the impossible task that you may believe it to be. After all, a successful graphic is measured foremost by its ability to effectively communicate an idea. As a child, you probably created a successful drawing in the form of a dot-to-dot puzzle. Even a person endowed with little more than rudimentary hand-eye coordination can move a pencil in a fairly straight line from point A to point B, from point B to point C, from point C to point D, and so on. The finished dot-to-dot image will look the same and will communicate the same idea, with the same degree of clarity, whether completed by a modern-day Leonardo da Vinci or a careful child. Both Leonardo and the child possess the same innate ability to connect dots with a pencil. If both also possess the same determination to accurately follow the puzzle directions, both can master this simple drawing process.

The primary difference between the experienced artist Leonardo and the inexperienced child is that the artist knows how to draw without numbered dots as a guideline. Based on experience, the artist knows:

1. where to begin and end pencil strokes to accurately represent an image;
2. which stroke to create first and which to create last;
3. what tools are available and how each tool is operated;
4. that drawing is not an exact science, and there exists a generous margin for trial and error. Any stroke applied may be erased, reapplied, re-erased, and so on, until the stroke satisfies the imagined design.

An artist's knowledge is gained through a combination of reading, observation, and personal experience.

An artist's knowledge, like *all* knowledge, is gained through a combination of reading, observation, and personal experience. An artist is no more born with artistic knowledge than a banker is born with a knowledge of monetary exchange or thirty-year mortgage rates. An artist is born with the interest and attitude necessary to develop his or her drawing ability.

The next section examines how an artist uses a personal computer to create a graphic.

The electronic graphic process

Creating a graphic on a computer can be broken down into four parts:

1. Determine your purpose in creating the graphic, and develop a basic concept.
2. Create a series of rough sketches, representing every idea that you and your associates have come up with.
3. After selecting a favorite sketch, polish the sketch into a final draft or finished drawing.
4. Save the final draft and all preliminary sketches for future use.

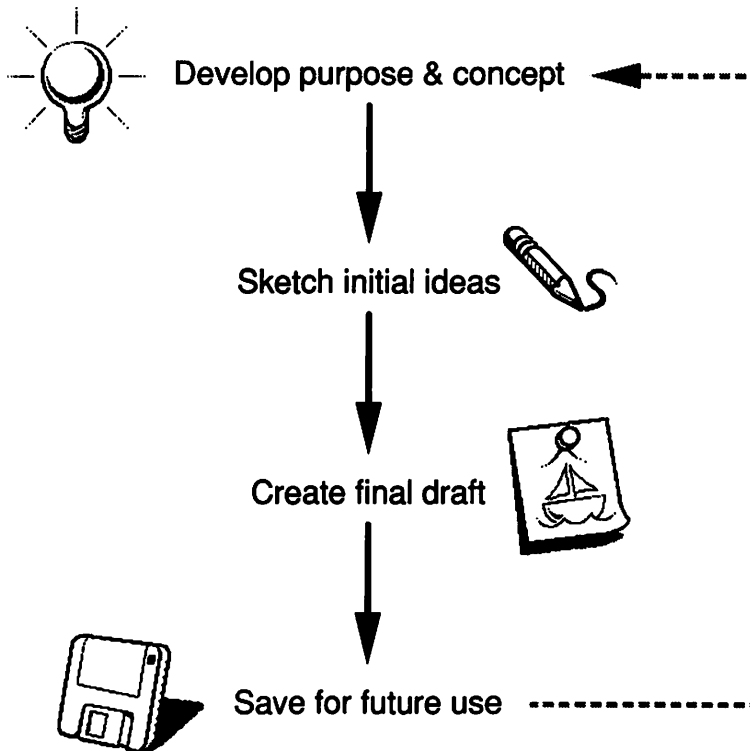

The electronic graphic process is cyclic—a single drawing can be used over and over.

As we shall see, the graphic process is cyclic. A single electronic drawing can be used over and over again in a variety of circumstances. The icons shown in this figure appear throughout our text, highlighting discussions of corresponding topics.

The next few pages describe the steps in the electronic graphic process in detail, and examine how each relates to other steps and to the process as a whole.

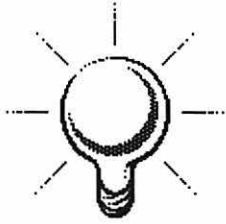

Developing purpose and concept

Before you draw a single line inside any paint program, you must have a clear idea of what you want to draw, and why. A drawing must have a definite purpose, whether it relates to a paragraph of text in a newsletter or stands alone as a calendar illustration.

The intention of a drawing should be forthright and obvious. A successful graphic explains itself without words. A graphic should provide a viewer with enough visual information to render any surrounding text largely repetitive, thus thoroughly preparing the viewer for your textual message, whether commercial or personal. Outside a museum or art class environment, viewers are rarely prepared for obscure or ambiguous visual themes.

A graphic should provide viewers with enough visual information to render any surrounding text largely repetitive.

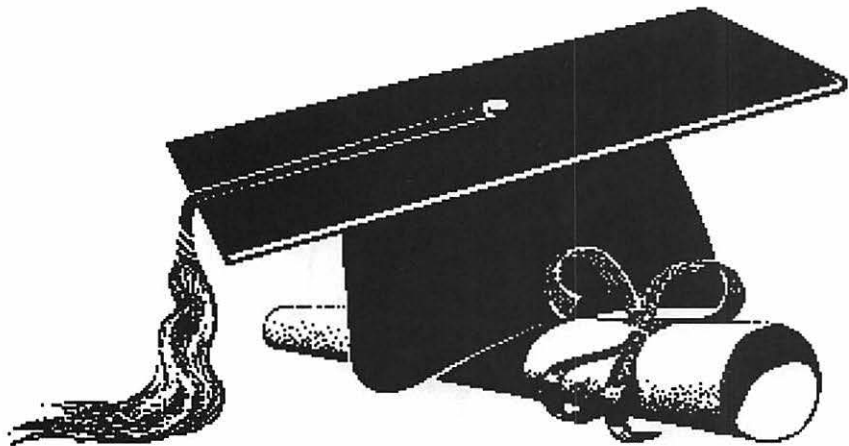

A drawing of a mortar board with a scroll requires no text to convey the theme of a high school or college graduation. It prepares the viewer to read text about graduation topics, such as party or gift information or job possibilities.



It is desirable to conceptualize drawings that are not only interesting, but also clear in purpose.

Placing our mortar board on a car roof obscures our message. Not only are mortar boards and cars unusual visual partners, but their size relationship is unrealistic. The graphic is more interesting than its predecessor, but more difficult to interpret.

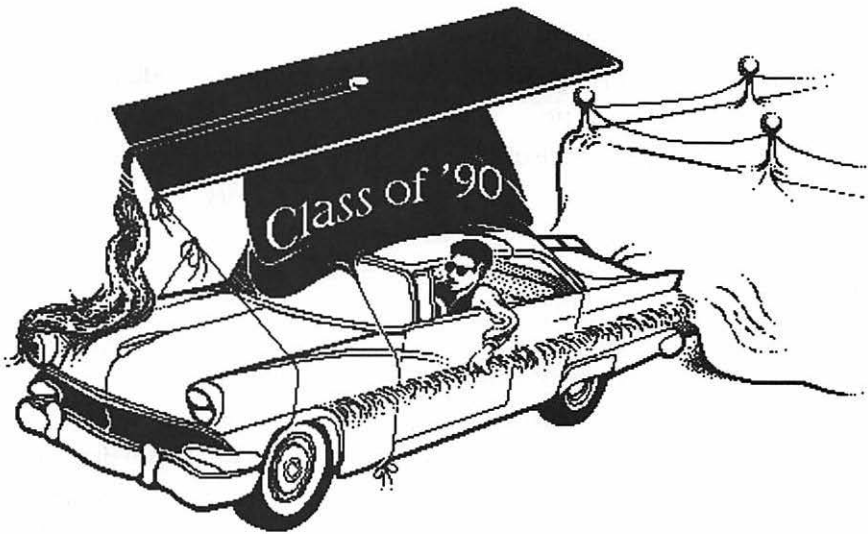

An ambiguous graphic can often be clarified by adding detail. In this case, we have transformed the surrealistic cap on a car into part of a parade float. In doing so, we have retained the graphic appeal of the previous figure while also refining its purpose.

When determining the concept for a prospective drawing, you must isolate your needs and your restrictions. Before your graphic can serve a purpose, you identify that purpose. Sometimes it can be helpful to make a list of your intentions. For example, if you are creating an advertisement for a brand of dog food, you know that first and foremost you want to interest dog owners—your graphic should be able to attract all dog owners. Suppose that you are also concerned that you don't offend owners of cats or birds, since your company produces many varieties of pet food. Therefore, although a drawing of a fierce retriever chasing after the neighbors' Siamese cat might amuse and attract many dog owners, it will no doubt repel cat owners, proving itself an unsuitable theme. You must find a happy medium that encourages dog owners to buy your brand while demonstrating to non-dog owners that your company is sympathetic to all animals.

Below are some of the most common categories of graphic needs and restrictions. Each consideration should be addressed when developing any business graphic:

Needs:

1. Primary purpose of graphic
2. General company interests
3. Clarity of concept
4. Overall appearance of final draft

Restrictions:

1. Time constraints, including deadline
2. Budget constraints
3. Printing restrictions and costs



Sketching initial ideas

Once you have firmly established your intentions, you may start drawing. However, do not feel compelled to create a perfect piece of artwork on your first try. Drawing is a process, not a goal. While you draw, you will often discover ideas and possibilities that you had not initially considered. One pencil stroke may suggest several others, each of which may take your drawing in a different direction. By creating several sketches for a single graphic, you take advantage of many ideas, possibly more than one at a time.



Sketching is a quick, intuitive process that allows you to transfer an idea to paper in a matter of moments. Many ideas may be materialized in a short period of time. Sketches may also themselves suggest other ideas to be sketched.

Sketching is a method for trapping ideas. Before you judge an idea to be good or bad, get it down on paper. The sketching process is not generally a time for evaluation; it is a time for fast, informal, and unstified production. You will have plenty of time to scrutinize your ideas later.

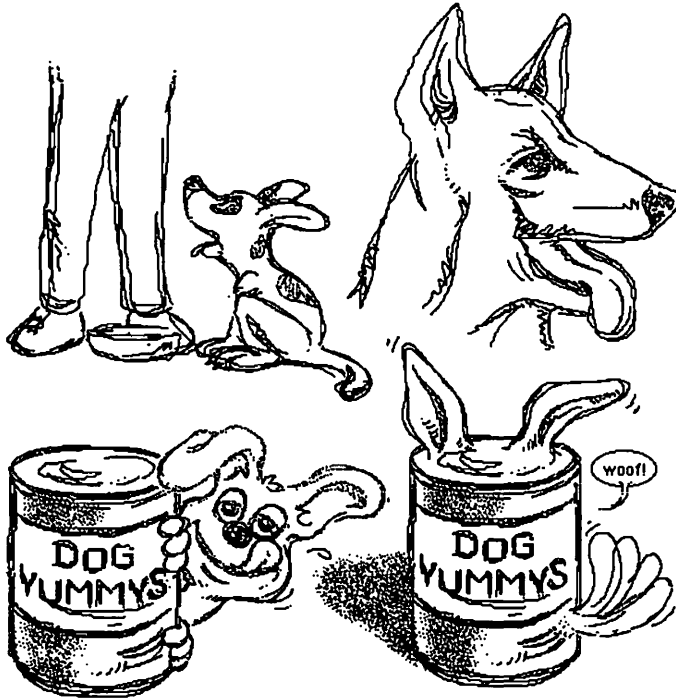

*Sketching is
a method for
trapping ideas.*

Suppose that these four sketches are a random sampling of those that we have created for the dog food advertisement. Don't worry if your sketches do not look this nice. Sketches should contain only a bare minimum of visual information to remind you of an idea later.

When sketching for your own purposes, it is rarely necessary to worry about the quality of the sketches. Their only purpose, after all, is to help you organize and promote your ideas. If you are creating sketches to present to

other people or business associates for consideration, we advise you to create a second series of sketches, representing only your four or five best ideas. Polish them enough to display your skills and effectively demonstrate your ideas.

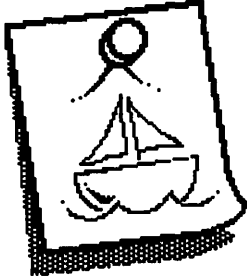

Creating a final draft

Having a variety of sketches to choose from provides you with a degree of freedom in approaching a graphic. No part of the effort required to create the final drawing need be directed toward identifying the concept. Once a favorite sketch is selected, you can work it into a final draft. If more than one sketch is impressive enough to warrant further deliberation, create final drafts for two or more sketches.

The final draft stage is your opportunity to work in a graphic style.

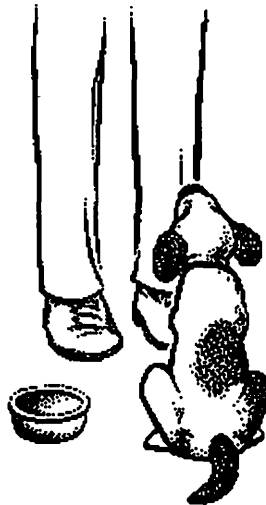

This graphic of a dog waiting patiently to be fed is not only endearing to dog owners, but inoffensive to other pet owners as well. We have developed it from our first sketch in the previous figure using a simple approach. The three objects—the man, the dog, and the bowl—are positioned in a basic triangular arrangement.

The final draft stage is your opportunity to work in your personal drawing style, which we will discuss more fully at the end of this chapter. You may also fine-tune your idea to more accurately fulfill your purpose.

If you're wondering how to create a final drawing, take a look at Chapters 5, 6, and 7 of this book. These chapters present the step-by-step evolution of several final drafts in an easy-to-follow fashion.

Saving drawings for future reuse

No drawing should ever be considered a waste of time. An idea turned down today may be picked up tomorrow. Save all your drawings, especially sketches. Sketches can provide a substantial resource for future works. You might be surprised to learn that many "new" graphics are really developed from sketches that were passed over several years ago.

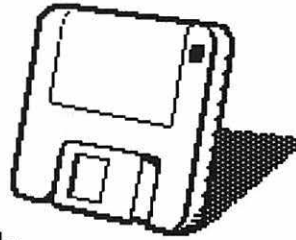

All artists possess piles of early artwork at which they cringe to look. But even these rudimentary efforts can provide raw material and inspiration for new pieces.

The electronic environment makes it very easy to borrow from old drawings. Images created previously can be copied and pasted into new backgrounds to create new graphic effects.

Save all your drawings; an idea turned down today may be picked up tomorrow.

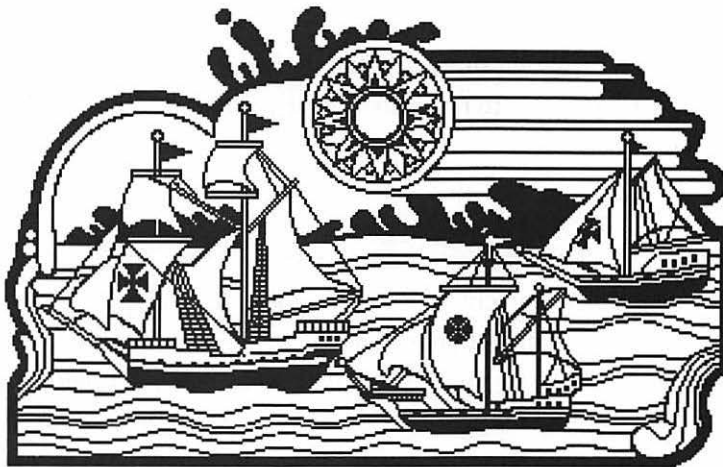

This drawing was created to represent the Niña, Pinta, and Santa Maria sailing to America. It is a few years old now, but we have never disposed of it. You never know when a graphic may prove useful in a new context.

The final step in the graphic process, saving a file to disk, is straightforward. In most paint applications, saving is accessed as a menu command, a practice familiar even to those with limited computer experience. The first step, developing a concept, is probably not foreign or intimidating either. If you've worked in advertising, visual media, printing, or any related field, you may have been involved in formulating graphic ideas that were later transformed into illustrations by a staff artist. Even if you have never worked with an artist or marketing committee, you have probably imagined visual ideas that could be worked into a drawing. Something as elemental as a dream, for example, is fundamentally a visualization of a concept, an idea entirely your own.

For most non-artists, steps two and three are the most difficult, since they involve actual drawing. If we were to end our discussion here, you would understand how to create a graphic without knowing how to draw, an overt oxymoron. For this reason, most of this book is devoted to analyzing the process of drawing and applying this knowledge to standard graphic types using a typical paint application.

Sketching initial ideas and creating a final draft are steps in the graphic process that require drawing technique.

Examining drawing technique

Whether you are using pencil and paper or mouse and keyboard, the effectiveness of your graphic depends on your drawing technique. *Technique* refers to the knowledge and tools that an artist uses to create an illustration.

Most artists are educated in form, scale, proportion, depth, and related subjects. This knowledge of drawing theory guides an artist through an illustration, providing a basis on which to make decisions about what goes where and how things should look.

An artist's tools include pencils, paint, brushes, paper, and canvas. In a paint application, these tools are accessed by clicking icons in an electronic toolbox. Understanding the purposes as well as the possible uses of tools enhances an artist's technique.

By gaining an understanding of drawing theory and software tools, a computer artist assembles an electronic drawing technique—the essential link between formulating a graphic concept and expressing it identifiably on paper.

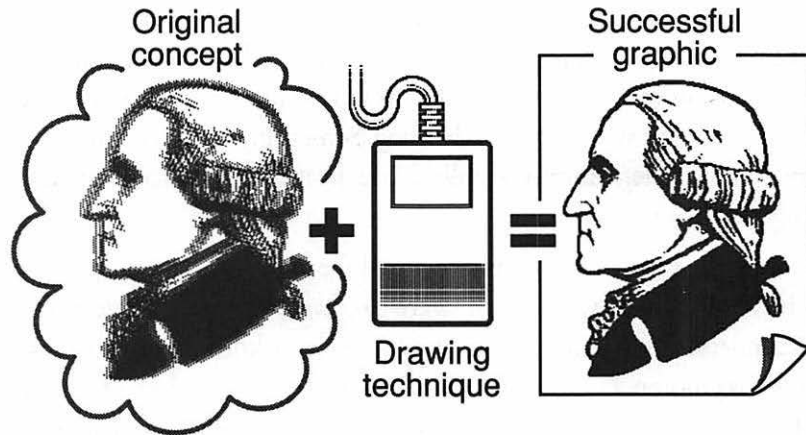

You can learn to draw by developing a successful technique, regardless of any preconceptions of natural ability.

A understanding of theory and tools forms the foundation of a successful drawing technique, which provides the knowledge required to move your mouse in the directions and distances necessary to convert a mental image into a visual form.

Technique differentiates those who can draw from those who cannot. By developing a successful technique, a person can learn to draw, regardless of any preconceptions of natural ability.

The qualifier in this discussion is the artist's style. Any two contemporary artists may have the same educational background and access to identical tools. However, one artist's technique may be less successful than the other's simply because of a difference in artistic style. In this sense, style not only dictates the appearance of an artist's work, but the manner in which it was created as well.

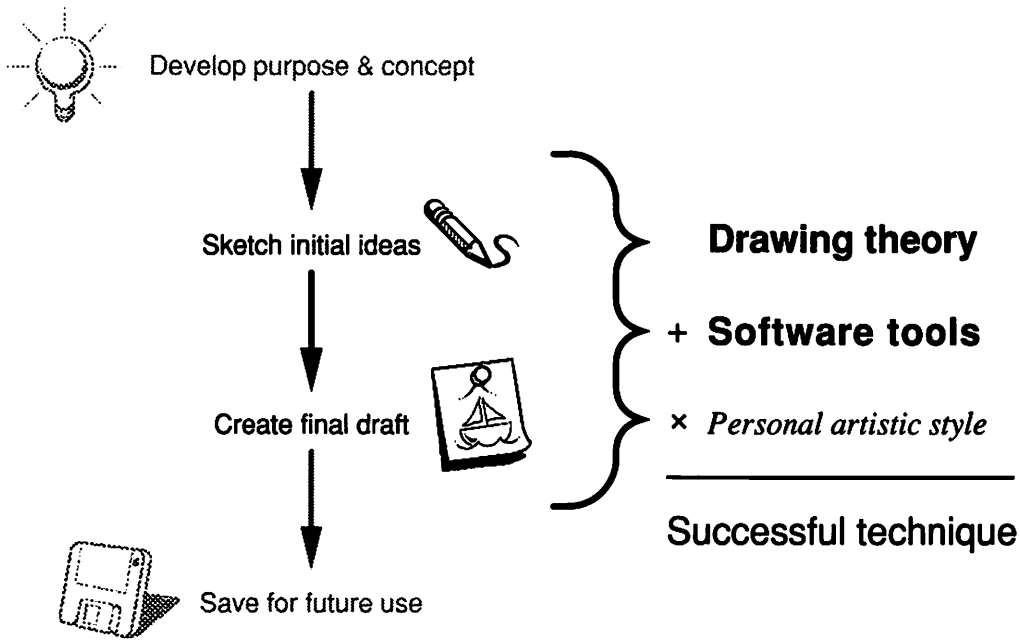

Sketching initial ideas and creating a final draft are steps in the drawing process that require a successful drawing technique. And as we have indicated in the figure, a knowledge of drawing theory plus an understanding of software tools, modified by your personal artistic style, equals technique.

Being able to draw is therefore the integration of knowing how to draw and knowing what to draw with. As you might suspect, these topics are so large that our first four chapters are devoted to aspects of drawing technique. Chapter 2 is an in-depth examination of drawing theory, including form, scale, proportion, and depth, which we mentioned earlier. In Chapter 3, we examine the tools and menu commands available in most painting applications. In Chapter 4, we point out some possible uses of these software tools.

That leaves only artistic style, the modifier of drawing technique. Style is a considerably smaller, less tangible subject. We will discuss style for the remainder of this chapter.

Being able to draw is the combined result of knowing how to draw and knowing what to draw with.

Personal artistic style

Every professional artist has a distinctive style. The appearance of each drawing created by an artist is immediately recognizable as typical of that artist's work. You are probably familiar with many artists' styles even without knowing their names. That familiarity provides a link between artist and viewer which helps win the viewer over to your product or idea.

A distinctive artistic style serves a product or company more effectively than a generic style, even when the technique is flawless.

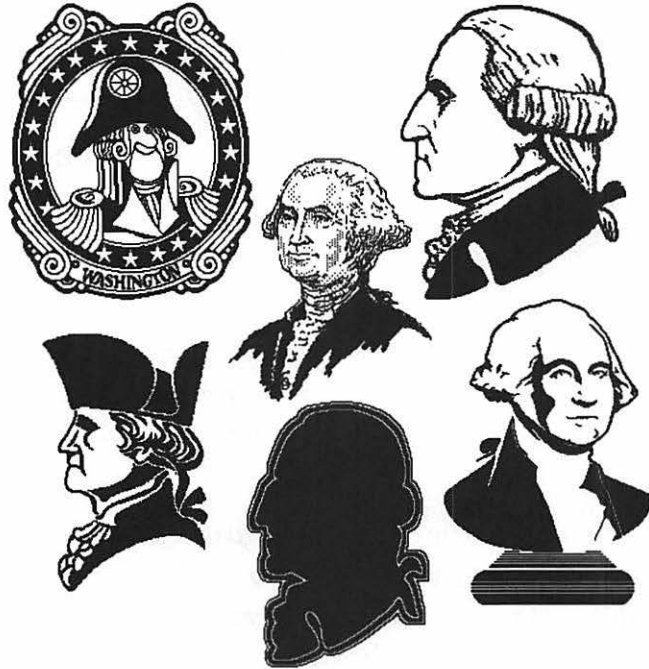

Each of these six drawings depicts George Washington, yet each differs from the others in one or more stylistic respects. The first George is a cartoon; the second George is drawn so lightly that it seems almost fragile; the third George is robust and confident; and so on. All are drawings of the same man, and many are drawn from the same angle. Nonetheless, each is clearly distinguishable from the others. Each is obviously drawn by a different artist. Each possesses a quality and character all its own.

A distinctive style serves a product or company more effectively than a generic style, regardless of the technical quality of the artwork. Since a viewer's affinity for a particular style may blind him or her to a flawed drawing technique, every artist should strive to develop a consistent personal artistic style.

If you are just beginning to learn to draw, you probably have yet to develop a artistic style. The easiest solution is to copy drawing styles of established artists. Avoid the mistake of trying to emulate the style of a *single* favorite artist. You may be far too successful! If your style is identical to that of another artist, you limit your creative development. A better idea is to borrow from many artists, carefully scrutinizing their work and borrowing only the few techniques from each that you find valuable.

For business reasons, you may wish to counterfeit the style of another artist. Rather than forsaking your personal style altogether, try to reach a compromise. You may work into your drawing to a sufficient degree a foreign style necessary to please your business interests, while at the same time displaying enough of your own style to further your personal goals and artistic development.

Besides helping an audience to identify your work, your style will play a decisive role in improving the quality of your work. We mentioned earlier that personal style modifies the way in which an artist applies knowledge of drawing theory and software tools. By working yourself into your artwork, you also work yourself into your technique. If you take the time to develop a personal artistic style, you will increase your artistic knowledge as well.

You can produce interesting effects by copying the content of one graphic and the style of another.

Drawing technique is a qualifying determinant in the graphic process, because if you can't draw, you can't sketch and you can't create a final illustration. As we have discussed, a knowledge of drawing theory and an understanding of software tools are two key elements to developing a successful drawing technique. Thorough examinations of these topics are contained in the next three chapters. The third key element, your personal artistic style, enables you to adeptly display your command of technique.

The time you spend developing a style will enhance your experience, increase your knowledge of drawing theory and software tools, and solidify your understanding of the graphic process in general.

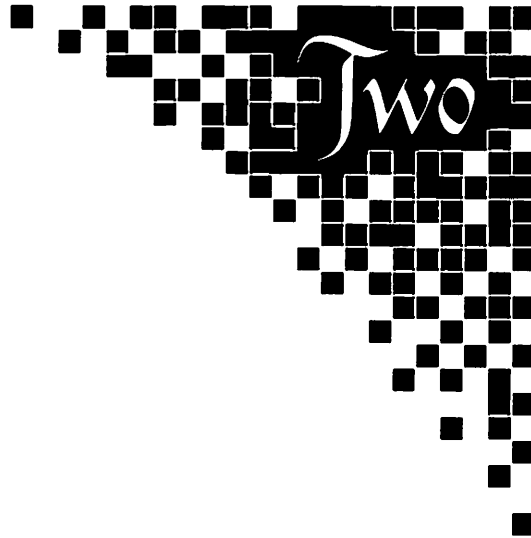

The Basics of Drawing Theory

In the previous chapter, we described technique as the combination of a knowledge of drawing theory and an understanding of software tools. The first half of technique—drawing theory—is the subject of this chapter.

In the same way that an understanding of tools can be considered an artist's practical knowledge, drawing theory is the sum of an artist's academic knowledge. For example, because of his or her understanding of tools, an artist knows that a pencil creates graphite lines when rubbed against paper. But if the artist wants to draw a graphite line that represents a duck or a tree or a house, he or she must rely on drawing theory. An artist uses theory to determine how lines should be drawn, how shapes should be formed, and how colors should be applied.

*Drawing theory
determines how
tools can be used to
represent images.*

Drawing theory may be broken down into many separate elements, which we will call building blocks. Each building block may or may not be used to create a particular graphic. This chapter focuses on each building block both individually and in relation to others.

The building blocks that compose a successful technique include:

1. *Presentation . . .*
How to draw professional graphics.
2. *Form . . .*
How to record the shape of an image accurately.
3. *Scale . . .*
How large or small to create each object with respect to other objects in the drawing.
4. *Proportion . . .*
How large or small to create each portion of a single object in relation to other portions.
5. *Depth . . .*
How to create the illusion of three dimensions on a flat piece of paper by using perspective, detail, and shades of gray.
6. *Volume . . .*
How to determine a source of light to create highlights, shadows, and reflections on an object.
7. *Color . . .*
How colors blend and interact and how to apply them using a color monitor or when printing in color.

The most advanced drawing technique will include a knowledge of all seven building blocks.

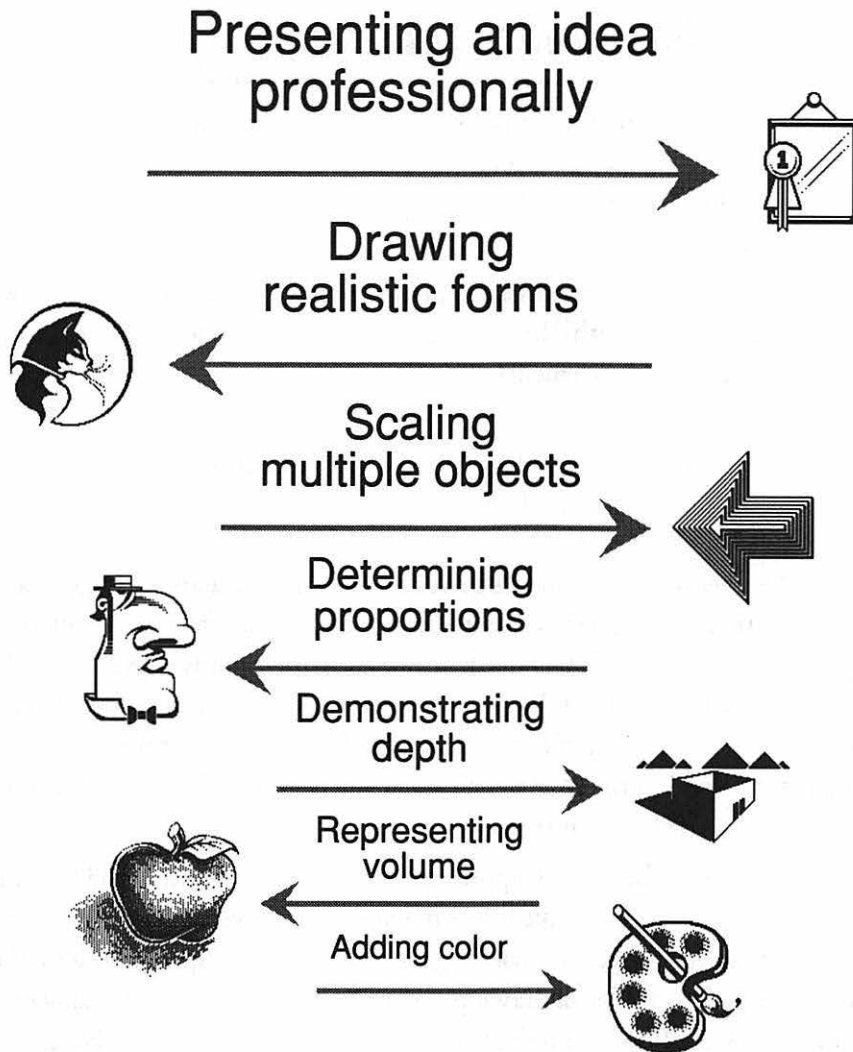

Throughout our text, we will use the icons shown in this figure to highlight building block discussions.

Each of our seven building blocks is displayed in order and size of importance. Throughout this text, we will use the accompanying icons to highlight discussions of corresponding topics.

The first building blocks are the most essential. For example, you might create a simple drawing using only your knowledge of the first building block—presentation. A more advanced graphic would also incorporate form. However, a drawing cannot successfully demonstrate depth without also successfully demonstrating proportion, scale, form, and presentation. The most advanced graphic will incorporate all seven building blocks.

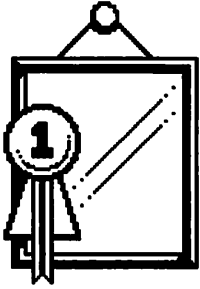

Presenting an idea professionally

A viewer or audience may love or hate your work regardless of its technical merit. In fact, a theoretically atrocious drawing can be very popular if the “feeling” is right. We call this intangible quality of a graphic its *presentation*.

The purpose of a professional presentation is to hide a drawing’s flaws and enhance its strengths. In this sense, we can best define presentation by separating it into two elements:

1. *Appropriateness*—does your drawing attract or repel viewers?
2. *Appeal*—is your drawing likable?

Neither of these elements serves to judge if your drawing is any good. Presentation deals exclusively with how your graphic affects a viewer, regardless of the graphic’s technical qualities. In other words, presentation determines first impressions. Either a viewer likes your drawing immediately or the drawing fails to fulfill its purpose. In the world of commercial art, there is no middle ground. After all, you can’t dismiss a viewer’s lack of enthusiasm by attributing it to your own artistic genius.

A drawing that is both appropriate and appealing elicits good first impressions, even if it looks like it was drawn by a four-year-old. For example, a typical four-year-old draws with big fat crayons on newsprint. Because the child has no knowledge of drawing theory and a limited understanding of his or her tools, the finished product is usually technically worthless. Nonetheless, if you saw this child’s drawing on a holiday greeting card, you might find it very endearing. The presentation is appropriate because a greeting card is a light-hearted, informal message. The presentation is appealing because holidays are typically nostalgic times when people enjoy being reminded of their childhoods.

By contrast, a drawing that is neither appropriate nor appealing elicits bad first impressions. If you went on vacation to a foreign country, and discovered that their money had a child’s drawings printed on it, you would very likely board the next flight home. There is nothing childlike about economic security, and such play money might appeal only to counterfeiters.

Presentation deals exclusively with how your graphic affects its audience.

For the next few pages, we will concentrate on appropriateness and appeal individually.

Appropriateness: drawing for your audience

Even the most expertly crafted drawing can fail to account for its audience. By considering the suitability of your graphic concept in terms of how it will affect a viewer, you address the most important element in creating a successful drawing—appropriateness.

Suppose that when creating our dog food advertisement in Chapter 1, we had decided to present a cat eating the dog food. No matter how well we had drawn the cat, it would not have impressed dog owners, for the simple reason that they buy dog food for their dogs to eat, not for cats. Our audience would have ignored the drawing from the outset.

Appropriateness is therefore the fundamental manner in which a concept is conveyed. It determines whether a graphic is noticed or neglected entirely. If a graphic is uninteresting or offensive to your intended viewer, then its presentation is inappropriate.

Appropriateness determines whether a graphic is noticed or neglected entirely.

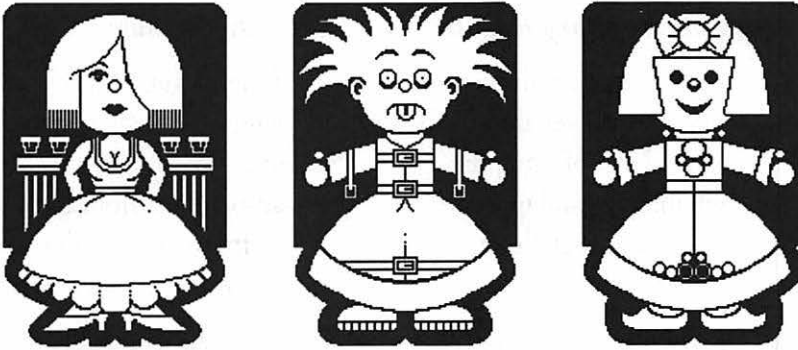

Suppose we want to draw a simple wooden doll for a general audience. Above are three examples of possible final drafts. Each drawing is similar in style, but presented differently. The first doll is presented as a shapely barmaid, the second is presented undergoing electroshock therapy, and the third is presented as a little girl with a bow in her hair. For very specific audiences and environments, the first two dolls might be appropriate. But only the last doll can be considered appropriate for most viewers.

You have to inspire your audience to look at a drawing and to like it.

An appropriate drawing gets noticed; an inappropriate drawing gets ignored. Hence, appropriateness is the primary determinant of first impressions. If you don't draw for your audience, they aren't going to pay attention to your work. When sketching your first ideas, concentrate on a presentation that will immediately grab the attention of your viewer. If your audience likes dogs, represent your idea appropriately and include a dog.

An appropriate drawing hooks its viewer. That's half of what presentation is about. But you have to do more than make an audience look at your drawing; you also have to inspire them to *like* it. To be effective, a graphic must be appealing as well as appropriate. The following text explains why.

The importance of an appealing presentation

Appeal is instrumental to the success of a graphic due to the basic relationship between your graphics and any surrounding text. By nature, a graphic is more visually entertaining than a typical block of text. The visual appeal of graphics account for their abundance throughout printed advertisements and commercial text.

A graphic is exciting because:

1. It represents an idea intuitively. A viewer absorbs the general idea of a graphic subliminally and notices more subtle details after a brief gaze.
2. It visually resembles something encountered in day-to-day life.
3. It stands out from a sea of gray text and demands attention.

Text is dull because:

1. It defines an idea through a series of abstract marks and symbols. Few readers absorb ideas from the written word faster than from an effectual graphic.
2. It visually resembles nothing, except countless other gray blocks of text.
3. It blends in with the rest of a printed page. A typical block of text does not jump out at you.



To achieve an appealing graphic, we recommend these guidelines:

The three guidelines to creating an appealing graphic are to draw large, elegantly, and consistently.

1. Draw large. Fill your allotted space generously. A scrawny drawing surrounded awkwardly by too much white space and filled with squashed, unidentifiable details is not visually appealing. If a drawing turns out to be too big for its space, it can always be reduced after completion. (Enlarging a too-small graphic is unacceptable, since the result is jagged and grainy.)
2. Draw elegantly. Represent an image powerfully, or delicately, or athletically, or in some other positive posture that fits the circumstance of your graphic. Exaggerate aspects of your image that you think will impress your viewers; de-emphasize those that might be disagreeable or even offensive. Represent an image the way you think your viewer will most like to see it.
3. Maintain a consistent style throughout your drawing. For example, don't stylize one portion of an image and then make another portion very realistic. By drawing inconsistently, you draw undue attention to your style, diminishing the effect of your illustration as a whole.



The above drawing isn't horrible, but it lacks appeal. It also violates every one of our three guidelines for an appealing presentation. First, it's scrawny. It fills so little space on our page that a viewer's first reaction might be to feel sorry for it. Second, it is not represented in a positive posture. A bird bending over pecking out the ground is unlikely to elicit a positive reaction from an audience. Third, it has been executed with little regard for consistency. The body of the bird is heavily stylized, while its feet are represented with a surprising regard for accuracy. The ground is also inconsistent, full of specks and blotches found nowhere else in the drawing.



This drawing depicts the same bird shown in our previous figure. It is not drawn any better than the first drawing, yet it is more appealing because the presentation is better. First of all, it's larger: It fills the page better and therefore appears stronger, more impressive. Second, the bird is depicted standing upright. This change in posture makes for a more dynamic illustration, suggesting a bird ready to leap into flight. Third, the style of the graphic is consistent. The legs are represented as simple straight lines, more in keeping with the simplified body of the bird. The ground is squared off and the specks are uniform in size and shape. The result is a very appealing bird.

Anything that calls as much attention to itself as a graphic had better appeal to its audience.

A graphic dominates text for control of the printed page. Anything that calls so much attention to itself had better be good. Your audience is likely to forgive a graphic's boldness, even admire it, if the graphic appeals to them. By following the three rules for creating an appealing presentation—draw large, draw elegantly, and draw consistently—you make your audience like your drawing. And if they like your drawing, they'll be more receptive to your message and more likely to read any surrounding text.

A first impression is often the only impression an audience will form about your work. The manner in which you present a graphic invariably determines that first impression.

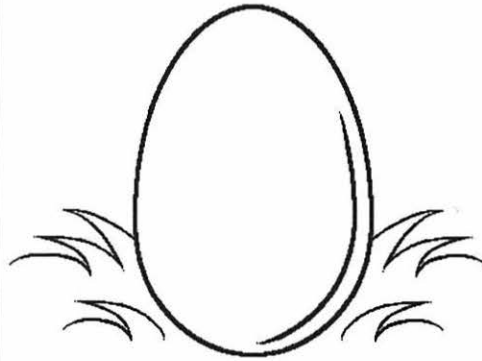
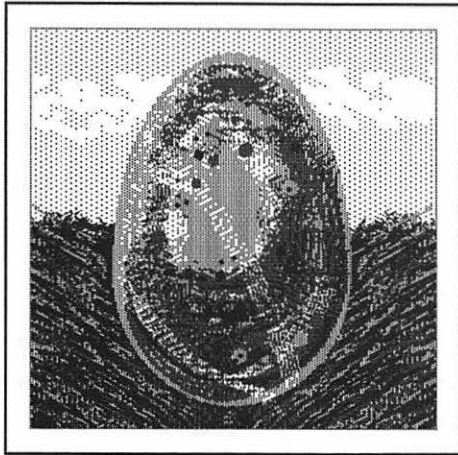

Here we have two versions of an egg sitting in a grassy lawn. In the first image, the form of an egg is expressed realistically using shading and gray values, as it would be in a photograph or a painting. In the second image, we express the form of the egg as an oval outline. Regardless of their differences, both drawings accurately demonstrate the form of an egg. But obviously, the outlined image was much easier to create and required less skill and effort.

Notice the grass in our two representations of an egg. When drawing the grass for our outline drawing, we could have created a bunch of small lines or even tried to trace the form of each individual blade. Instead, we saved both time and effort by demonstrating the form of the grass as a whole. Although we have simplified it to its bare essentials, the lawn remains easily identifiable.

Whether you are trying to record a simple or complex image, start by outlining its basic form. This will allow you to successfully represent the image quickly, and may serve as a starting point should you decide to add more detail.

The following discussion is designed to help you to learn how to quickly read the basic form of an object and draw it on-screen.

New artists often run into problems when they draw the way they presume an object to look, ignoring its real form.

Recording form accurately

The best way to learn to represent form accurately is to draw from real life or from photographs. This way, you don't have to remember or imagine how something looks. The biggest problem that new artists have is they draw the way they presume objects to look, ignoring the real forms. If you frequently consult your model while drawing—concentrating on drawing an object as it is, not as you think it is—you will have more success.

Here are three experiments you can try to improve both your drawing skill and your knowledge of form. All are intended as experiments only; they should not be adopted as permanent drawing habits.

1. While sketching, keep your eyes on your real-life or photographic model. Never look at your computer screen.

This is similar to typing without looking at the keyboard. You are forced to rely exclusively on your model for form information rather than making up forms based on the evolving structure of your drawing. Since it is often difficult to remember what you have drawn and it is impossible to know where you should begin and end lines, your completed sketch will probably be a mess. Only after you have finished your sketch should you look at your computer screen, adding details and making corrections based on what you have drawn. Your increased knowledge of the real form of your model will also help in this correction phase.

2. If you are drawing from a photo, turn it upside down, and try drawing it that way.

An object is much less familiar when viewed upsidedown. You will be less tempted to make up a form as you draw if you have no preconception of what the form should look like. Once your sketch is completed, rotate the entire image right side up. You'll be surprised by how good it looks!

It is easiest to record the actual forms of an image if you draw from a model and refer to it often.



3. Fill your entire screen with black. Then work backward, drawing with your pencil tool to subtract lines that should *not* be there.

This is similar to whittling wood. You essentially carve away parts of your drawing that shouldn't be there, rather than adding lines and shapes. Like the previous experiment, this unfamiliar drawing method forces you to further examine your drawing technique.

Simple, accurate forms are easily recognizable to a wide variety of viewers.

As we mentioned earlier, these are only experiments; they are not intended to be substituted for your normal drawing procedure. However, you will always find that it is easier to record the actual forms of images if you draw from a model and refer to it as often as possible.

By learning to record realistic forms, you can effectively communicate your idea to a viewer without wasting a lot of drawing time. Simple, accurate forms are easily recognizable by most viewers; inaccurate forms, no matter how detailed or elegantly shaded, are frequently confusing.



Although it may be difficult to recognize the image on the left, these are two representations of fish. The first image is very detailed, but its form is highly inaccurate. Obviously, the artist did not consult a model. The second image required much less time to draw but more accurately reflects the outline of a fish. Its simplicity supports its clean, crisp appearance.

An audience recognizes accurate forms and is confused by inaccurate forms. Accurate forms don't have to be complex; in fact, they may be created using only one or two lines. To ensure that your outlines are accurate, try to always draw from a model, whether real-life or photographed.

With experience, you can stylize the outlines of an object to enhance an illustration.

An image is most recognizable when you represent the form of an object accurately. But unfortunately, the real world can sometimes be a little dull. For example, the fish on the right of our figure may be easily recognizable, but it isn't as exciting as the image on the left. Does realism have to be boring? What is the purpose of drawing if the best you can do is no better than real life?

You can do better than real life. In fact, one of the primary functions of art is to enhance nature. In the next few pages, we discuss methods for enhancing reality that involve the manipulation of form.

Stylizing form

Only after you understand how to create realistic outlines can you manipulate form to enliven an illustration. We offer two methods that may be used by intermediate artists to enhance form. The first of these is *stylization*.

To stylize an image is to represent it as a series of geometric shapes. As long as these shapes are based on realistic forms, you can achieve fantastic drawings that remain fundamentally recognizable.

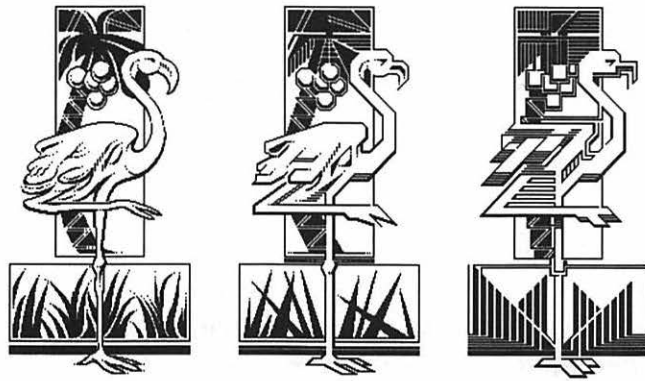

In each graphic above, we have used outlines to express selected details of a flamingo and its environment. Each drawing stylizes the form without obscuring it. The first bird is drawn naturalistically, but its background is divided into stylized frames of plant life. We slightly straightened the outlines of the second bird. And by the third graphic, we have represented the image entirely as perpendicular lines and 45° angles. The forms of all three birds are equally accurate, despite their different interpretations.

Stylizing details in the outline of an object produces an exciting image that enhances realism without departing from it entirely. In addition, geometric images are a perfect extension of your computer's capabilities. Painting applications respond to your drawing strokes by turning on and off tiny screen pixels. Each pixel is a tiny square, 1/72-inch wide. When these tiny squares are combined to create larger squares, rectangles, and other polygons, the results are apt and elegant. Stylization is one way of expanding your working knowledge of form that is particularly applicable in an electronic environment. Using methods that are suited to your computer allows you to have fun with a drawing and translate that enthusiasm to your viewer.

The second method for enhancing reality does not involve altering form, but rather involves organizing it. We call this method composition.

Composition: the consistent flow of form

As we mentioned, reality can be boring. In the case of our flamingo, we enhanced reality by stylizing the many small forms that make up the bird and its environment. We straightened the lines in its beak, we combed its feathers into evenly spaced rows, we made its background more geometric. But sometimes, the effectiveness of your drawing is less dependent on the numerous small forms of an object and more dependent on its overall form. How do the various details of your model relate to each other? If you're drawing a face, how does one eye relate to the other? If you're drawing a person, how do the arms relate to the torso and the legs? This overall sense of form is *composition*.

Think of your drawing as a river. A river that flows in a straight line or consistent arc allows water to pass through it more quickly than a river that winds back and forth, crimping about small nooks and pools. Likewise, your drawing will be more effective if it follows a straight line or consistent arc. Since fluid composition is rarely seen in real life, it is an effective means of enhancing reality in your artwork. Like water in a river, a concept flows more quickly from artist to audience through a linear drawing.

You rarely see a fluid composition in real life, which is why it's such an effective means of enhancing reality with your artwork.

The concept of a graphic flows most quickly through a linear composition.

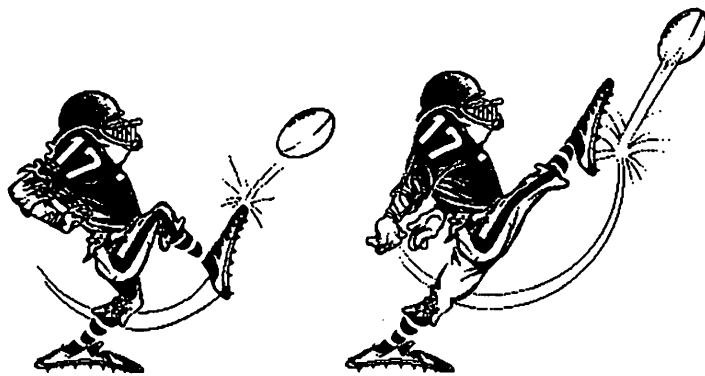

Both of these cartoon athletes are reasonably accurate in form. Yet the punter on the left appears awkward, scrunched up, as if he is neither powerful nor skilled. Although a person might actually kick a ball while assuming this position, there is little reason to represent an athlete in this way. You might prefer to show him in the stance on the right. This guy seems to be knocking the football out of the stands! His form moves in a consistent direction, thus the composition is linear.

Often, linear composition requires that you alter the form of an image slightly from its real-life or photographic model. In such a case, you might find it helpful to first draw the object just as you see it. Then rearrange the details of the object using the various paint application commands to be discussed in the next chapter. In this way, you may alter a drawing's composition without disturbing the forms of an object.

Composition is based on form. Forms are the outlines of various parts of an object; composition is the outline of the object as a whole. Composition is an element of drawing theory useful to the intermediate artist, because only after understanding form can you master composition.

An accurate outline of the basic form of an image is essential for conveying your idea quickly and clearly, without numerous details or complicated effects. Representing an object in a linear composition increases the effectiveness of your graphic by enhancing reality. Together, a knowledge of form and composition can be used to turn scrawls into elegant line drawings.

Form is a theoretical tool. A knowledge of form allows an artist to communicate unambiguously to a viewer. Our next building block, scale, is also theoretical tool. A knowledge of scale opens additional visual possibilities for an artist.

Scaling multiple objects

In the first section of this chapter, we mentioned that enlarging the overall size of a graphic increases its appeal. But within a single graphic, you may also increase or reduce the size of one object in relation to other objects. For example, suppose that you want to create an illustration depicting a giant and a dwarf. Naturally, you would draw the giant much larger than the dwarf to communicate their considerable difference in height. Relative sizing of various objects within a single graphic is called *scaling*.

It is often useful for an artist to scale individual objects in a graphic to different sizes. In fact, contrast in scale can be extremely useful to indicate one of the following visual themes:

1. *Actual size differences.* Some objects are larger than others. For example, a giant is bigger than a dwarf.
2. *Distance.* An object in the foreground appears larger than a similarly sized or even larger object in the background. If a dwarf was very close to us and a giant was very far away, the dwarf would look bigger.
3. *Importance.* Scale can be used to highlight important visual concepts or accompanying text. If you wanted to show that dwarves constitute a larger percentage of world population than giants, you could exaggerate the relative size of the dwarf.
4. *Drama.* Very large objects and very small objects can be coupled to produce very dramatic results. By increasing the scale of our giant tenfold, we elevate our drawing from dwarf with giant to Jack and the Beanstalk!

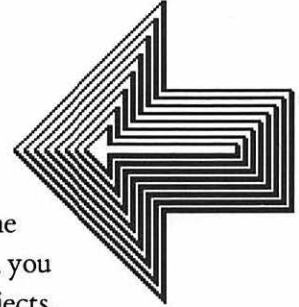

Scaling objects to different sizes is an effective means of communicating various physical and abstract relationships.

Distance: scaling between foreground and background

In real life, you see objects scaled in proportion to their distance from you. As an example, hold your finger an arm's length from your face. As you slowly move your finger closer, it consumes a larger portion of your field of vision, thus appearing larger. In this way, your finger can be made to seem as large as a distant car or building. If you move it away, it takes up less of your field of vision and appears to shrink. The size that you perceive an object to be depends on your distance from that object.

Since scale is not constant in real life, you should alter the scale of objects in your drawings as well. Objects should be exaggerated or downplayed in scale to indicate their proximity to the viewer. An easy first experiment is to consider your drawing as consisting of only a foreground and a background. Draw all foreground objects at one large scale; draw all background objects at a smaller scale. (If more than one object exists in either the foreground or background, those objects should be scaled according to their actual size relationships.)

Objects are enlarged or reduced to indicate their proximity to the viewer.



Here we have drawn a bowler and his ball at the same scale, sized in normal relationship to each other. Both the ball and bowler appear to be in the foreground of our graphic.

*Relatively small
objects appear
to be at the back
of a graphic, large
objects look nearby.*



By exaggerating the size of the bowling ball, it seems to be rushing at us. Although the ball is huge by comparison to the bowler, the graphic remains identifiable because we perceive the ball as being closer to us. In addition, the fact that we have both a foreground (the bowling ball) and a background (the bowler) enhances the reality of the graphic by giving it the appearance of depth (a topic discussed more fully later in this chapter).

If you want to show that one portion of a graphic is in front of another portion, increase its scale. Likewise, if you want an object to appear behind others, decrease its scale. Relatively small objects appear to be at the back of a graphic, large objects look close up.

When you scale objects according to their actual size relationships or according to their distances from the viewer, you are using scale realistically. But as we mentioned in our discussion of form, it is possible to enhance reality and excite viewer interest. Like stylization and composition, using scale to indicate importance is a method for enhancing reality without diminishing viewer recognition.



Scaling to indicate importance

Rather than representing objects realistically, scale can be used to represent things idealistically. In this way, scale highlights the relative importance of images. Large objects tend to look formidable and impressive; smaller objects look less important, more incidental.

As an example, consider a graphic accompanying a story in a business journal. The story is about how foreign small car manufacturers are taking a bite out of the big luxury car industry. A huge compact is shown running over a tiny Cadillac. Although a compact is a much smaller car than a Cadillac, the graphic is recognizable as a deliberate distortion of reality. Scaling for importance allows you to impart a message without confusing your viewer.

In this sense, unusual contrasts in scale can be applied to indicate differences in popularity, skill, intelligence, strength, competitiveness, productivity, quality, durability, value, potential, notoriety, intensity, and growth. Even negative or questionable attributes such as risk, opportunism, takeovers, terrorism, deficit spending, and substance abuse can be illustrated by distortions in scaling.

Scaling for importance imparts a message without confusing the viewer.

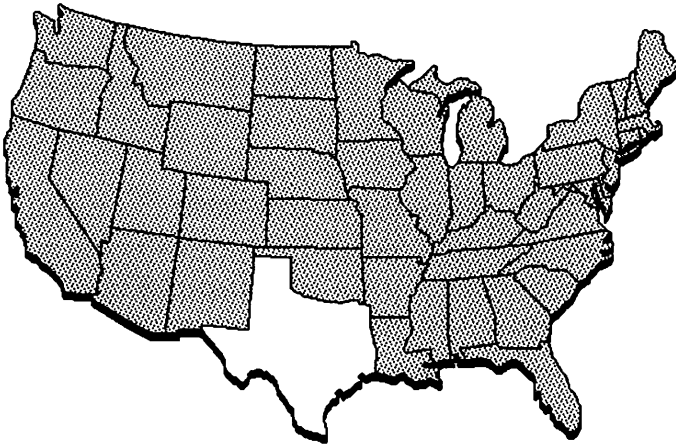

Here, all 48 continental United States are shown at the same scale, each state sized accurately in relation to its neighbors. The state of Texas is subtly emphasized by shading it white while shading the surrounding states gray.

When drawing an object, consider its importance in relation to other objects in your graphic.

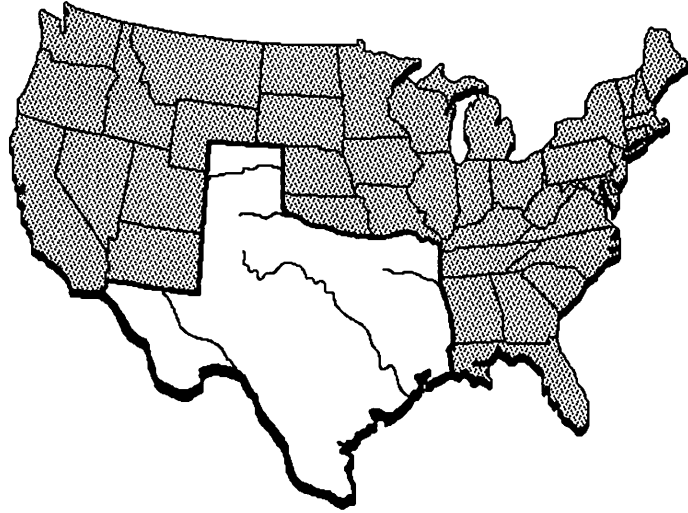

By increasing the scale of Texas, we attach additional importance to it. It has become so important, in fact, that surrounding states are deformed or lost entirely. Viewers familiar with the U.S. will understand that this is not how Texas and its neighboring states really look, but that the graphic emphasizes some area in which Texas excels.

Use scale to guide your viewer. Incidental graphic elements should be small. In the previous figure, every state except Texas is drawn to a consistent scale, since their only purpose is to serve as a contrast to the enormity of the Lone Star State. If every state was large, Texas would not stand out and would therefore seem much less important.

When drawing an object, consider its importance in relation to other objects in your graphic. If you want one object to attract more attention than another, increase its scale. If you want to downplay an element's importance, decrease its scale. And if you want all objects to share the same importance, keep their sizes realistic.

The final effect of scaling also departs from reality, but not so blatantly. Rather, differences in scale are exaggerated to produce dramatic results that excite viewer attention without imparting a specific message.

Scaling for drama

Huge size differences between objects can provide very impressive and dramatic results. For example, one reason the redwoods of northern California are so popular is because of their immense size relative to other trees. In the same way, vast contrast in scale increases a graphic's effect on viewers. This is especially true if a very large object is positioned close to a very small object, whose size is readily identifiable. A viewer should be able to immediately recognize the small object as something that is not commonly associated with smallness, such as a animal, car, house, and so on. The small object thus demonstrates the immensity of the larger element.

*A small object
may be used
for contrast,
demonstrating the
immensity of a
large object.*

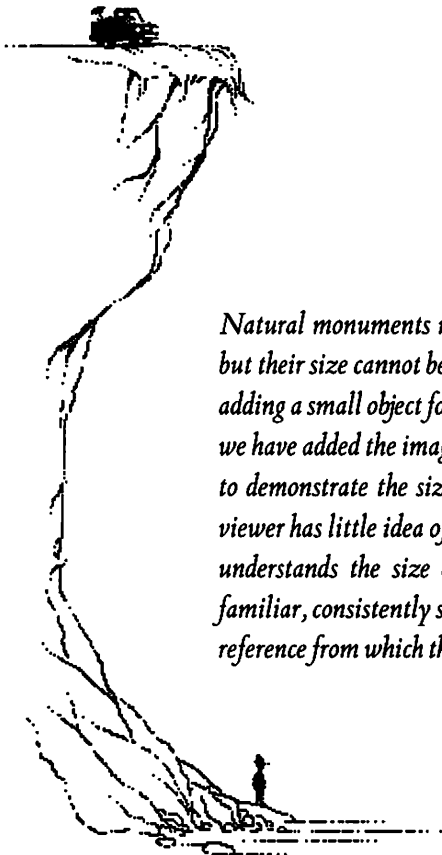

Natural monuments make for dramatic illustrations, but their size cannot be gauged by an audience without adding a small object for scale reference. In this graphic, we have added the images of a man and a truck in order to demonstrate the size of a rocky cliff. In general, a viewer has little idea of the height of a typical cliff, but understands the size of a human or a truck. These familiar, consistently sized elements provide a tangible reference from which the size of the cliff can be inferred.

Whenever you represent grandiose landmarks or dramatic natural monuments, scale can play an important role. Position a small, familiar object alongside or atop the landmark to demonstrate its largeness and drama. By introducing a small object, your large object seems larger, and your drawing seems more expertly crafted and interesting.

When a graphic contains more than one object, consider how each should be scaled.

Scaling is a useful method for enhancing your graphics. But keep in mind that it is useful only when a graphic contains more than one element. Increasing the size of a single-object graphic can also increase its effectiveness, but is more a function of presentation, discussed earlier.

Any time your graphic contains more than one object, consider whether some objects should be scaled for the sake of reality, to demonstrate distance, to highlight importance, or to increase dramatic impact.

The fourth building block of drawing theory is proportion. It is very similar to scale, in that proportion can be used to indicate several visual themes. But since proportion is a more advanced theoretical tool than scale, its impact on a graphic is more subtle and more discrete.



Determining proportions

We have discussed how the scaling of various objects can enhance a graphic. Another form of scaling can be used to affect the appearance of a single object. Details and features of an object can be scaled independently of each other within the single element. This technique is known as altering the *proportions* of an object.

For example, a woman is unhappy about her looks. She thinks men find her unattractive because her nose is too large. She hires a plastic surgeon to reduce the size of her nose by an operation. In effect, she has altered the proportions of her face to enhance her appearance. As an artist, you can likewise alter the proportions of objects in your drawing to enhance its appearance.

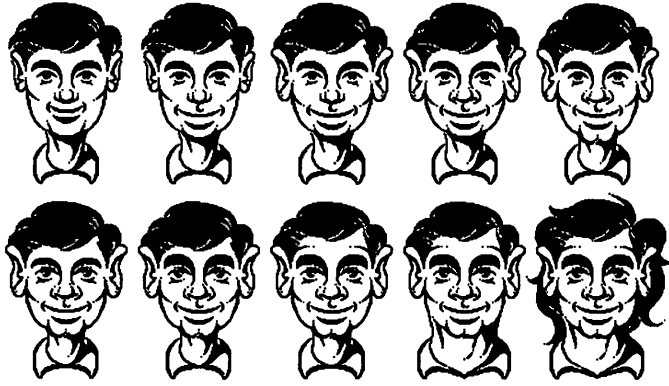

Each of these ten heads is a caricature of the same person. The only difference is in the proportion of the features. Starting with the top left face and working our way across the rows, we enlarge one feature at a time. First we enlarge the mouth, then the ears, the nose, the chin, the eyes, the eyebrows, the forehead (giving our man a receding hairline), the neck, and finally we lengthen the hair. The result is that the last face looks very different from the first. Notice, however, that we never alter the size of the head itself, retaining the same basic framework.

An object may be made to look very different by altering its proportions.

It is often useful to consider proportions of various features within an element. Proportional differences and oddities may serve several purposes:

1. To accurately represent the proportional differences that exist within an object. Some objects are short and fat, others are tall and thin, others have big ears, and so on.
2. To make an object more interesting. Sometimes reality isn't as entertaining as fiction. By enhancing reality, you can produce more eye-catching results.
3. To force visual relationships between objects. If two or more objects in a drawing share an unusually large or small feature, they have an immediately obvious relationship that lends a semblance of harmony to your work.

Each of these three results of altering proportions is discussed in the following pages.

Making an object more interesting

By altering the proportions of an object, you can improve on reality, especially when a real-life or photographic model is flat or uninteresting, and requires some sprucing up. You may even find that exaggerating a proportion or two adds power or grace to a graphic.

Suppose that you are creating an illustration for an article in the company newsletter featuring an employee of the month. This employee is a woman who single-handedly saved the company from crisis, and you want to create an image of her that will inspire the admiration of her colleagues. Unfortunately, our hero is not much to look at. If you draw her as she really appears, fellow workers may be more bewildered by her abilities than impressed. By exaggerating those features that are becoming and downplaying those that are less becoming, you alter her proportions in a way that benefits the article.

But how do you know what proportions you can exaggerate without potentially confusing your audience? The rule of thumb here is to avoid altering those proportions that help a viewer to identify an image. Since people recognize an elephant by its long trunk, you should exaggerate the trunk by lengthening it, but not by shortening it. If you want to exaggerate portions of a fish, make its fins bigger or smaller, but you shouldn't lose the fins entirely or substitute legs.



You may heighten reality by altering a proportion or two. The fish on the left is accurately drawn, but he lacks flair. By subtly enlarging its fins, gills, and scales, as well as enhancing his mouth and eyes, we produce the more visually entertaining fish on the right. With very little effort, we have developed our fish almost to cartoon proportions, without overwhelming the simplicity that marked our original fish or detracting from viewer recognition of its fishy appearance.

Exaggerating elegant features and downplaying homely details can enhance your graphic's message.

To highlight an object to make it more interesting, you may exaggerate appropriate proportions. Just be careful that your exaggerations don't obscure the object's identity, so that viewers no longer recognize it.

Our next method uses similar proportions in separate objects to visually link the objects.

Forcing visual relationships between objects

Another method for enhancing reality is to "similarize" proportions of different objects. By attributing a similar feature to multiple images, you force a relationship between those images. These simple object-to-object resemblances can add a general feeling of harmony to your work, yet they require little time and effort.

For example, if you create a graphic in which two persons share an enlarged or unusual feature, your viewer will assume that they have something more in common as well.

Objects that share an identical feature are generally assumed to share something more in common as well.



The woman and man in this graphic are each wearing a fake nose, glasses, and mustache. You may also notice they are holding similar drinks. These affinities draw a viewer into the graphic. Do these two know each other? Will they ever meet? They seem to have so much in common!

Forcing relationships between elements sparks an audience's interest in a graphic. Similar proportions pose questions about a drawing, perhaps inspiring a viewer to inspect your work further or read accompanying text. Mysterious or unusual artwork always grabs a viewer's attention.

When creating any object in a graphic, consider its proportional relationships. Perhaps some features should be scaled within various objects to represent reality more accurately, to enhance reality, or to unify multiple elements in your graphic.

The remaining three building blocks—depth, volume, and color—represent the most advanced methods of drawing theory. Adequate graphics may be produced without any knowledge of these methods. However, by understanding them, you will gain insight into creating sophisticated, expertly crafted illustrations in an electronic environment.

Demonstrating depth

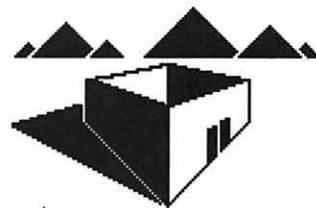

Whether you are drawing with a pencil on a sheet of paper or with a paint application, you have only two dimensions at your disposal: height and width. How do you create depth? Everything comes off looking flat. How do you draw a road stretching off into nowhere? Or an expansive mountain range? Or even a simple three-dimensional box?

The answer is *perspective*. As explained in the next few pages, you may use perspective to demonstrate depth in a drawing, giving any illustration an intensely realistic quality. After all, everything you see in the real world has height, width, and depth. Your most accurate representations must demonstrate all three of these attributes as well.

Use perspective to demonstrate all three dimensions—height, width, and depth.

Understanding perspective

Perspective is a method used to imitate a third dimension. It can breathe life into a lackluster illustration by adding depth. While not a simple method, it can be mastered with a little effort. We will begin by demonstrating a very simple use of perspective to create a three-dimensional box. Captions under each of the following figures outline the steps to creating our box; the text below the captions explains how each step works and why.

The horizon is a horizontal reference line that determines how every portion of a shape is drawn using perspective.

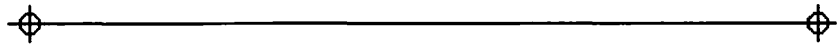

First, draw a straight horizontal line. This will act as the horizon.

The horizon is where the earth meets the sky. It is also the middle of your field of vision. As an object gets farther and farther away, just before it becomes invisible, it will become a speck on the horizon. Suppose you're watching a plane fly away from you. The farther away it flies, the smaller it becomes, and the smaller the distance between it and the horizon line becomes. The plane not only seems to shrink, it also seems to fly closer and closer to the ground. Prior to disappearing entirely from view, the plane becomes a speck that seems to touch the horizon.

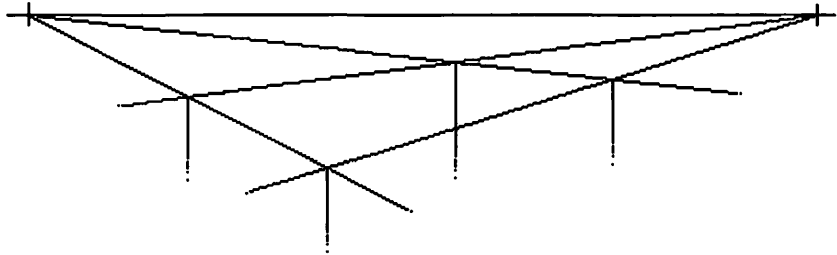

Draw two short vertical marks at opposite ends of the horizon. These will act as reference points. Don't worry about the exact location of your reference points, as long as they are spaced far apart. From each reference point, draw two angled lines, for a total of four lines. Each line from one reference point should cross both lines from the other reference point, as shown above.

If you are facing north and a plane flies overhead going due northeast, it will disappear into some point on the right half of the horizon. Likewise, if the plane is going due northwest, it will disappear into some point on the left half of the horizon. These are our reference points. Each reference point indicates the exact point at which the object that we are drawing would disappear if it moved a great distance in the direction of its width or in the direction of its depth.

Take the example of a box. A box has six sides. One side faces up and one faces down. The other four are oriented vertically and face in different compass directions. Suppose we position our box so its four vertical sides are facing directly north, east, south, and west. We then look at our box so that we face northeast. Since we are facing northeast, the reference points for our box represent due north and due east. If our box were to move north (in the direction of its width), it would disappear into the left reference point. If our box were to move east (in the direction of its depth), it would disappear into the right reference point.

In the next example, we'll see how our four angled lines from the last figure represent the top of our box.

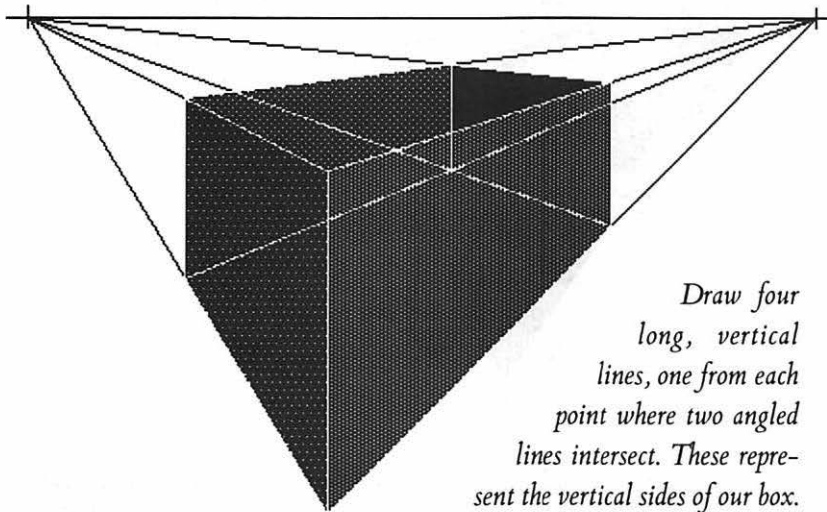

Draw four long, vertical lines, one from each point where two angled lines intersect. These represent the vertical sides of our box.

To create the bottom of the box, draw a point somewhere low on the vertical line that appears to be closest to you. From that point, draw a straight line to the left reference point and another to the right reference point. These are the outer sides of the bottom of the box.

A box, or cube, always has six sides: a top, a bottom, and four vertical sides.

We filled in the vertical sides of our box in the previous figure to better display how the final box would look. You can also see how each of the four vertical sides disappears toward one reference point or the other. Our box appears to be jutting out toward the viewer, demonstrating depth.

Any cubical object can be drawn in perspective using the method we have described in the previous pages. If you want to practice drawing different boxes, try moving your reference points to different locations on the horizon. Generally, the best perspective drawings have reference points that are as far apart from each other as possible. You may also experiment with adjusting the point on the foremost vertical line which we used to create the bottom of the box. The farther down you move this point, the more dramatic your perspective drawing will be.

You may also develop more complex objects in perspective by setting them inside your perspective box. The box helps to define the boundaries of the object. All details of your object should be created by drawing lines to your reference points.

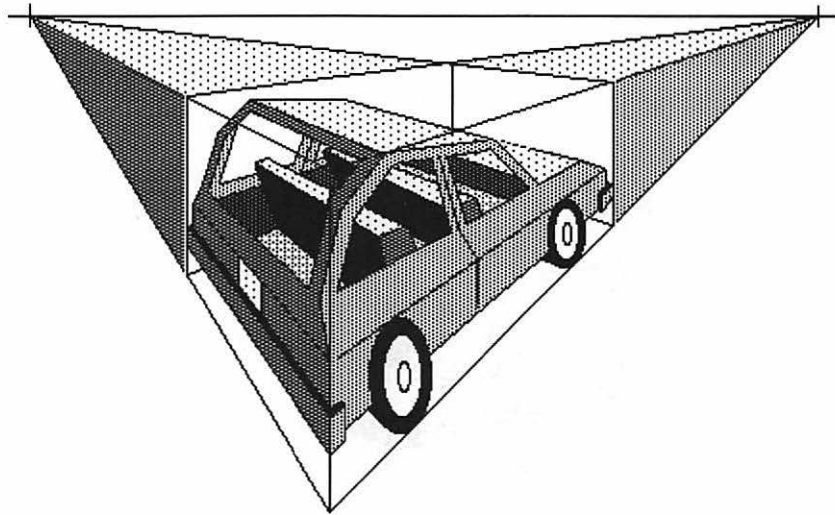

To construct a more complex object in perspective, set it inside of a cube.

To construct more complex objects in perspective, set them inside of a cube. The cube acts as a set of boundaries and references, and should be erased after your image is completed.

The three-dimensional box is the most basic of perspective experiments. Understanding the use of the horizon line and its reference points is the first step in learning how to represent depth. But perspective can be a difficult topic, so we'll expand on it. In the following discussion, we will use perspective to create an entire graphic that actually seems to disappear into the horizon.

Extending an object into the horizon

Suppose we wish to draw a long passenger train coming toward us. You may recall that in the *Scaling multiple objects* section of this chapter, we discussed how foreground objects are scaled large and background objects are scaled small. Therefore, the engine of our train will appear as the largest of the cars and the caboose will appear as the smallest. In the following example, the caboose is going to be so far away that we can barely see it. We will create a train that extends backward into oblivion.

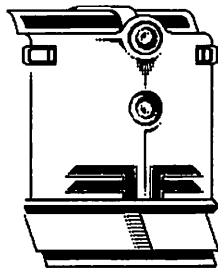

We begin very simply by creating the façade, or face, of our engine.

The façade of an image is like the façade of a building; it has no real depth of its own. It is simply the front of the object that we expose to the audience at all times, much like a mask. This allows us to use the same façade repeatedly while experimenting with multiple perspective versions of the rest of the object. Whether viewed from above or below, the façade is an easily identifiable element that always appears the same, thus saving us a great deal of time while testing out different angles of depth.

A façade that has no depth of its own may remain constant regardless of the perspective applied to the rest of the object.

By raising and lowering the horizon, we apply different angles of perspective to the train without altering the façade.

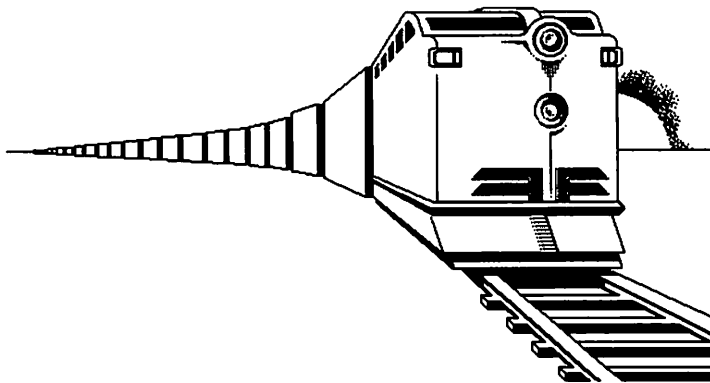

Here we have attached our façade to a series of very simple box-like cars. The farther the car is from the engine, the smaller it is scaled. The train track is drawn in perspective, as is the side of the engine. We have also added a sun to highlight our illustration and serve as a reference.

Notice the location of the horizon. It is even with the middle of the train. Since the horizon indicates eye level, we as the viewer are watching the train go by from a normal standing position. The middle of the train is even with the viewer's head. The tracks are at the viewer's feet; the top of the train rises above the viewer.

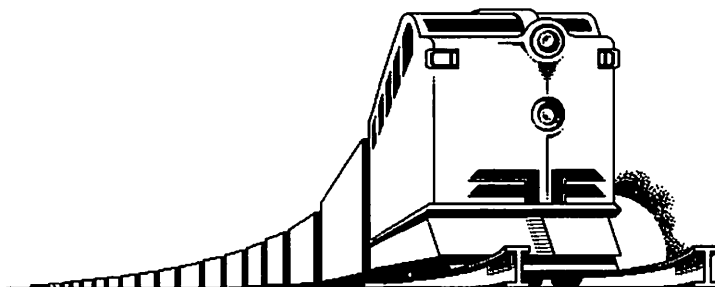

Now we attach our same façade to a different set of cars. We have lowered the horizon so drastically that the viewer's eyes are even with the ground. Since our horizon is lower, all perspective lines are drawn from the base of the graphic.

In the previous figure, we seem to be almost lying on the tracks, like some unfortunate damsel in distress. Even the rails of the track are taller than we are. This is what is known as a “worm’s eye view.”

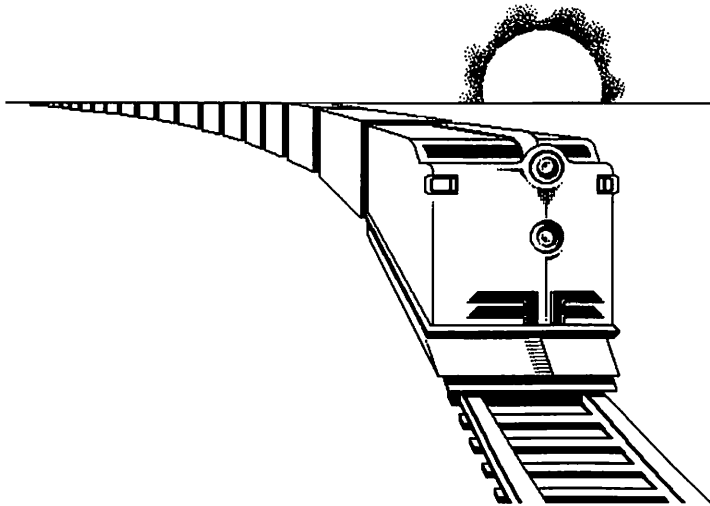

Perspective is a means for representing the location of the viewer in your graphic.

By raising our horizon, we rise as well. Notice that despite all the perspective adjustments, our façade remains unchanged.

In the figure above, the entire train is below us. Even the sun itself seems to be under our lofty gaze. This is called a “bird’s eye view.”

All of these train drawings are impressive to look at, despite the fact that they were simple to create. The only detailed part of our drawing—the façade—remains constant regardless of the elevation of the horizon. All portions of the figures that are subjected to perspective are simple in structure and design—just a row of boxes! The effect is elegant; the approach is minimalist, requiring little ability or time.

Perspective is a means for representing the location of the viewer in your graphic, thus drawing an audience into your picture. Use perspective when you want to create a realistic graphic environment that will impress people, warming them to your concept.

Another way to indicate that an object is far away is to draw a haze in front of it, as if it is obscured by ground heat, smoke, fog, pollution, or clouds. After all, if you can see clouds in front of an image, it must be miles from where you are.

When drawing a nearby object, represent as much detail as possible. If the object is far away, draw only the basic form of the object and enough detail to make it recognizable. And if it's somewhere in between, draw the object as you would normally, indicating accurate form, scale, and proportion to make your image recognizable. Focus gives your graphics an extra sense of depth and reality that your viewer will appreciate.

The third method for indicating depth is the easiest of them all. This method simply requires that you fill objects with lightening or darkening shades of gray.

Shades of depth

Our final method for indicating depth makes use of shades of gray. This technique is primarily used to represent depth among a group of distant objects. When a group of objects is far away, the closest of the objects should be darkest, the farthest of the objects should be lightest.

The best example is a mountain range. The entire range may be miles away. To effectively add depth and realism to your drawing, you want to indicate that some mountains in the range are closer than others. The most distant mountain is the lightest, the second to farthest is darker, the third to farthest is a little darker yet, and so on, until you arrive at the closest mountain, which should be almost completely black. No detail or focus is required, nor is any perspective. You simply fill each element with a gray value or color (if you have a color paint application) and the effect is achieved.

When a group of objects is far away, the closest of them is the darkest, the most distant is the lightest.

*If you want to
impress viewers,
add depth to
your drawing.*

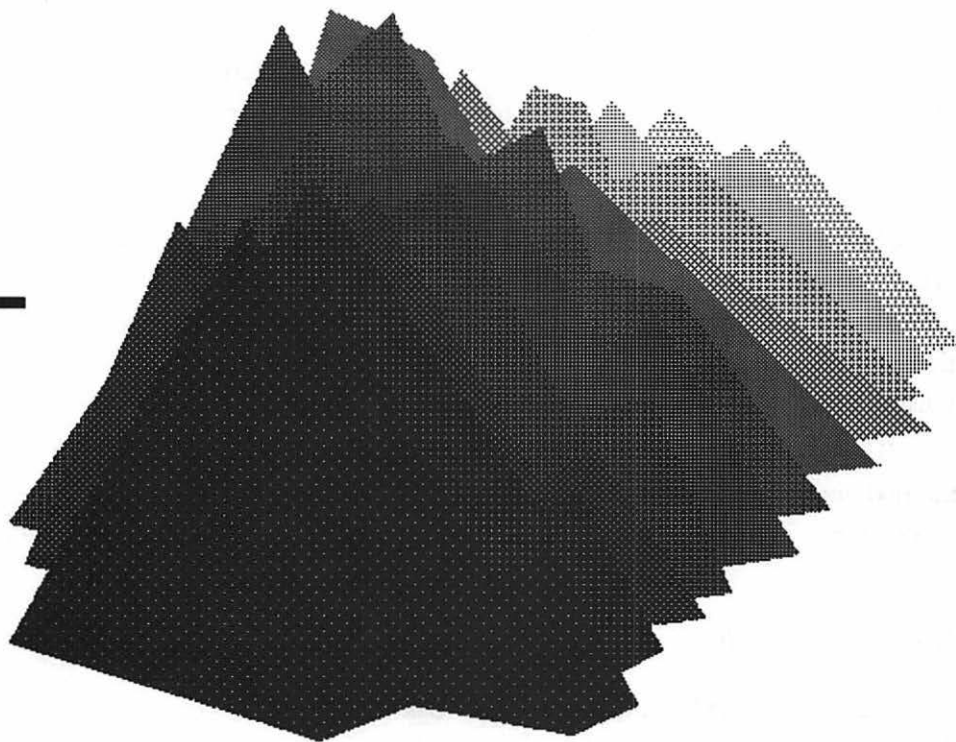

The first mountain in our range is almost black. As the mountains recede into the distance, the shades of gray lighten. The farthest mountain is the lightest shade of all.

Whenever you draw a mountain range or other far away group of objects, use different shades of a color to indicate depth. This is one of the simplest techniques in this book, yet—like most simple techniques—its effect is dramatic and immediately appealing.

Depth transforms your graphics from flat representations into pictorial environments. If you want to impress viewers, add depth to your drawing. Perspective, focus, and simple shading can add sophisticated realism to the most modest of graphics.

The next building block of drawing theory is volume, which can be used to demonstrate depth within a single object.

Representing volume

Perspective is a method for displaying objects in relation to their distance from the viewer. By contrast, volume adds depth to a single object.

For example, a globe of the world has volume. There is always one point that is closer to us than any other point on the surface of the globe. If we are looking at the ridges of the Swiss Alps, then Switzerland is closer to us than Canada, or Brazil, or Ethiopia, or Japan. If we spin the globe, some new country will loom toward us as Switzerland fades away.

Many other objects, such as cups, vases, lamps, tennis balls, and wheels, have volume as well. Even things that aren't round, like pencils, books, telephones, bricks, and radios, have degrees of volume.

To demonstrate volume, you must have a source of light to bring out subtle and dramatic shading differences. By using highlights and shadows, as will be discussed in the next few pages, you can give your drawings an added sense of dimension.

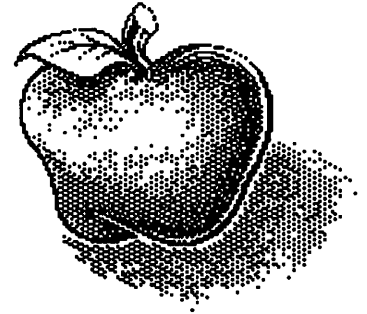

*By using highlights
and shadows,
you give your
drawings an added
sense of dimension.*

Understanding origin of light

Light is the most important element in rendering volume. After sketching the objects in your drawing, begin indicating volume by determining an origin of light, such as the sun or a lamp, which will be constant from object to object. All highlights and shadows will be based on this light source. A light source need not be displayed in your drawing. It may be implied, provided that the lighting is consistent from object to object.

The origin of light determines the size and position of highlights and shadows. Highlights appear at places where light is reflected off an object. Shadows appear where light is unable to reach regions that are blocked by the object itself. Another way to think of this is: if you were the light source, highlights would be the portions of an object that you can see and shadows would be the portions that you can't see.

The following examples demonstrate how to create a voluminous sphere using an origin of light to create highlights and project shadows.

Portions of an object that are touched by light are highlighted, those that are not touched by light dwell in shadows.

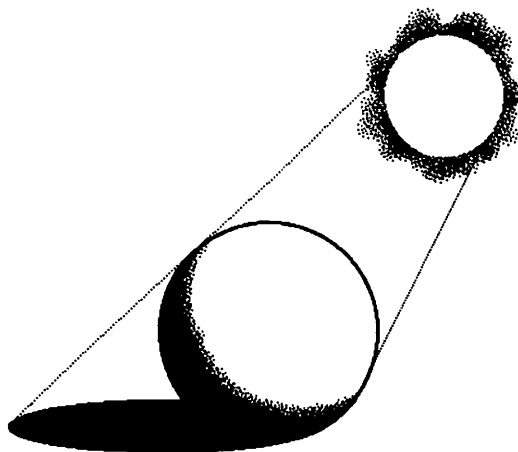

In the figure above, we have drawn a sun and a sphere. The sun acts as our light source. By drawing two sight lines from the sides of our sun to the sides of the sphere, we can determine how light is reflected and where light cannot reach.

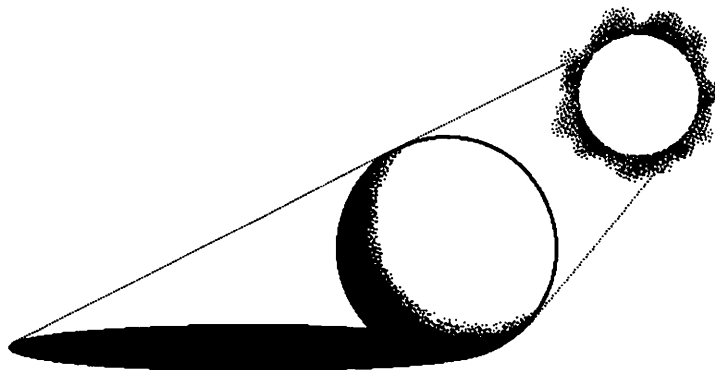

As we move the light source or the object, shadows and highlights change. Here we have moved our sun down and to the right. The angles of our sight lines have also changed, demanding a lengthened shadow and a rotated highlight.

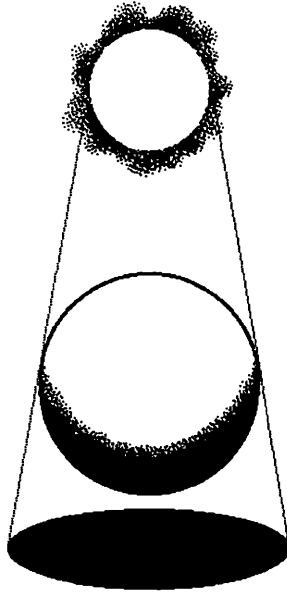

Now we have not only moved the sun, but the sphere as well. The sphere hovers above the ground, so that its shadow is no longer connected to it. The shadow is also shorter. Shadows are always smallest when the light source is located directly above an object.

Ground shadows can be used to indicate the nature of an object's environment.

In each of our figures, we have drawn sight lines that determine where shadows should begin and end. Also notice in each figure that we have drawn a shadow not only on the sphere itself, but also on the ground below. This is a simplified method for indicating the nature of an object's environment—whether the ground is flat or bumpy or jagged—without going to all the trouble of actually drawing a background, detail for detail.

Light demonstrates the volume of an object. Portions of an object that are touched by the light are highlighted, portions that are not touched are shadowed. Shadows can also be used to infer a background without drawing it in detail. Contrasts between dark and light indicate the volume of an image and add authenticity to your representation.

The next example demonstrates how to add shade and gradations to an object, to indicate a complex volume.

Shading and gradation

Creating highlights and shadows often involves more work than our sphere example might lead you to believe. Many objects have surface details that are best rendered with shading and gradation. A gradation is the gradual passing from one shade of a color to another. For example, suppose that you scribble on some paper with a piece of soft charcoal. If you rub at the scribble with your finger, you smear the transition between the black of the charcoal and the white of the paper, creating a gradation. Gradations can also be achieved in a paint program.

To demonstrate the use of gradation, we will create a voluminous object in four steps. The following examples begin with the construction of a simple vase and take us through to the definition of its light source and shading.

*It is often useful
to create an
exacting sketch by
using only
geometric shapes.*

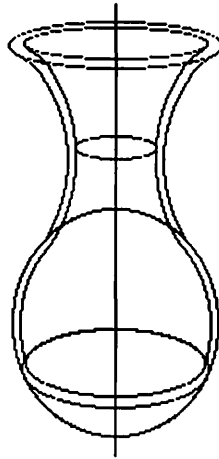

We construct our simple vase as the combined result of many circles and ovals. The line through the center demonstrates our initial regard for symmetry. Every curved line on the left of the vase is repeated in mirror image on the right.

It is often useful to develop an object geometrically. Try creating a sketch using only squares, rectangles, circles, and ovals. This provides you with an exacting base form, upon which you may later build in less rigidly.

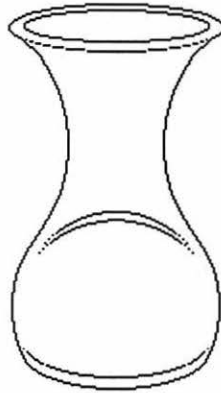

We erase the extraneous sketch lines to produce this crisp line drawing of the vase. The form is elegant and aesthetic, but so far there is no indication of volume.

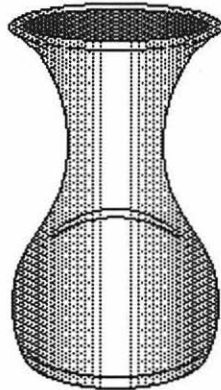

Next, we create two symmetrical gradations—one from dark to light and one from light to dark—inside the body of the vase. Inside the mouth of the vase, we darken the gradations. The addition of symmetrical gradations does not alone add volume, but it is a first step.

*An even gradation
can be used as a
sketch for more
complex shading.*

Notice that our first figure was a sketch of the form of the vase. The above gradation is a sketch of the vase's volume. Though we have yet to determine an origin of light or create any interpolative shading, we have provided ourselves with an excellent starting point.

Reflection and reflected light

Notice the shading underneath the vase in the previous figure. It begins as a nondescript shadow, then develops into a mirror image of the vase itself. This shows that the surface upon which the vase rests is shiny, or reflective. Perhaps it is a well-waxed table or porcelain countertop. In any case, by creating a vague mirror image of the vase, we not only demonstrate light and volume, we also define the background of our graphic. We imply the nature of the ground without drawing the ground itself.

Notice the shading in the body of the vase. The circular white area in the center of the bottom portion of the vase is surrounded by degrees of shading that fade from white to dark gray, and then to a medium gray. Rather than getting progressively darker, our shading gets dark, and then lightens. Why is this? How can shadows become lighter as they recede from the light source?

There is, in fact, a second light source. Since our table top is shiny enough to reflect the vase, it also reflects light from our source. This reflected light is dimmed, but it is sufficient to shed a highlight along what would otherwise be the darkest perimeter of the vase.

Use reflection and reflected light to imply the existence of an object's environment without displaying the background in full detail. These techniques are fairly advanced, but once mastered they save a great deal of time and add luster and elegance to your work.

By correctly displaying the qualities of volume, you demonstrate your knowledge of complex drawing theory.

Almost every object in real life has volume. By displaying highlights, shadows, gradations, and reflections, you show your viewer that you understand the appearance of things. This demonstrates your knowledge of complex drawing theory and makes for very impressive graphics.

Always consider your source of light in a drawing, ensuring that it is consistent from object to object. Concentrate on where light touches an object, and what portions of an object exist in darkness.

Our final building block involves the creation of full-color graphics.

Printing in color

If you or your company own a color laser printer or color dot-matrix printer, you may print small quantities of color graphics. You may also use color printers to print composites, which help you determine what your final printed graphics will look like.

If you do not have access to a color printer, the only way to create printed color graphics is through a commercial printer. This is an expensive process, usually requiring a run of more than a thousand copies to make the process cost-effective.

Always consult your commercial printer prior to creating any final outputs of your graphic.

There are two methods of commercial color printing:

1. Spot color printing is the cheaper of the two methods if you plan on using black and only one or two other colors. Spot colors are generally premixed according to the Pantone color matching system, an extensive catalog that displays and defines several hundred colors. Many color paint applications also support Pantone colors, so that you can emulate your finished artwork on-screen.
2. Process color printing is more expensive, but it also allows you to create every color in the spectrum by way of the CMYB or subtractive primary model. When printing to your laser printer, the painting software separates your graphic into four prints, representing its cyan, magenta, yellow, and black primary components. You then submit each of these sheets to your commercial printer. The commercial printer in turn produces multiple copies in four steps by applying cyan ink per your cyan separation, magenta ink per your magenta separation, and so on.

Whether you intend to use the spot color or process color printing method, you should consult your commercial printer prior to creating any final outputs of your graphic. You will want to ensure that the colors you see on your monitor closely match the colors produced by your commercial printer, particularly since your monitor and your printer use different color models. It is also a good idea to make sure that you can provide all the necessary original artwork. Miscommunications can lead to increased costs for paste-up and other last-minute problems.



Most importantly, give yourself plenty of time. If you are forced to create color printouts at the last minute, expect increased printing costs.

Using like and contrasting colors

If you intend to use a wide variety of colors in a single graphic, whether for on-screen presentational work or for process color printing, you should know how to use different colors to produce harmonious effects. Basically, two colors placed side by side will produce one of three results:

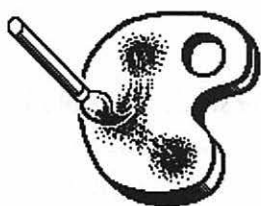

1. If the two colors are like pairs, they will blend into each other. Examples of like pairs are purple and violet, blue and cyan, green and emerald, pale ochre and lemon yellow, red and scarlet, brown and sienna, black and gray, and so on. Like colors are often used to produce gradation effects.

2. If the two colors are contrasting pairs, they will produce a sort of fluorescence at the point where they meet, as if the colors are bouncing off each other. Examples of contrasting pairs are deep red and bright green, orange and blue, lemon yellow and violet, and so on.



3. If the two colors are neither like colors nor contrasting colors, there are no specific implications. Thus they are called neutral pairs. This describes the majority of color pairs: gray and red, orange and turquoise, violet and emerald, and many many more.

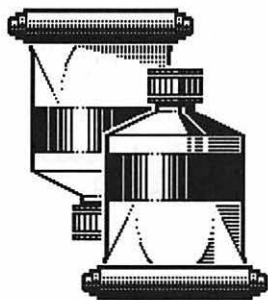

Whenever you draw in color, consider how colors appear when positioned next to one another.

In general, you can use like pairs and neutral pairs freely. Contrasting pairs, however, should be used sparingly. Contrasting pairs, like dissonant chords in music, can produce unpleasant results if used unwisely.

Whenever you draw in color, consider how colors appear when positioned next to one another. If the colors are like colors, they can flow together to produce shading effects, and discussed in the following paragraphs. If neighboring colors are neutral, your graphic will be safe. Juxtaposing contrasting colors is a bold gesture, producing dramatic effects if used with care. The more closely you consider your use of neighboring colors, the more tasteful and elegant your graphics will be.

Color shading

The last topic in this chapter is color shading. Color shading, like black and white shading, involves using progressively lighter or darker shades of a base color. You may create a lighter version of a color by decreasing its tint. Tint is measured in terms of percentage. Therefore, a 50% tint of red is half as dark as a solid 100% red. As you might guess, a 90% tint of a color and an untinted version of the same color would be considered a like pair.

Darkening a color is more difficult. Typically, the beginning artist will create a darker shade of a color by adding black to it. While not entirely unacceptable, this is not the best solution. Often, adding black to a color, especially to yellow, will produce muddy, unattractive results. The best solution is to darken the color by adding its contrasting pair partner. For example, if you wanted to produce a darker shade of blue, add some orange; for a darker shade of red, add green; for a darker yellow, add purple, and vice versa. Darkening by this method produces natural shades that mix well.

However, how this color theory applies to your specific color paint application will vary. Most programs use RGB color mixing models, some also offer CMYB, and some even allow you to mix two existing colors on-screen. But regardless, when shading a colored object, use tints to produce highlights and mixes containing contrasting colors to produce shadows. The result will be an attractive, gradual transition from color to like color.

You can create full color graphics that will impress audiences as no black and white drawing can.

General Introduction to the Painting Environment

As you may have already noticed, there are an increasingly large number of available paint applications, which vary greatly in price and sophistication. Although each application differs from its competitors in a variety of ways, all paint applications share several features which constitute the basic paint environment. We will discuss these fundamental similarities throughout this chapter.

To draw with any paint application, you must choose commands and operate tools. A command is chosen by pressing your mouse button on the menu bar, dragging down to the command name, and releasing your mouse button when the command name is highlighted. Generally, a command produces automatic results, as we will demonstrate later in this chapter.

All paint applications share several features which constitute the basic paint environment.

Drawing free-form lines and curves

When you draw with a real pencil on paper, you press the lead against the page and draw. The same is true when operating the pencil tool in a paint program. Hold down your mouse button and drag with the pencil tool. This creates a line that follows the path of your drag.

Even if you are experienced with drawing on paper, you may at first find it difficult to create clean, consistent lines in your paint program. This is primarily a matter of practice. Since a computer mouse is bulkier than a pencil, it may initially seem awkward and unfamiliar, but will become more familiar as you continue to use it. And the more familiar you are with moving your mouse, the better you will be able to use the pencil tool.

To quickly improve the appearance of your lines, try drawing very slowly. Especially when first drawing with a mouse, your accuracy will increase as your speed decreases.

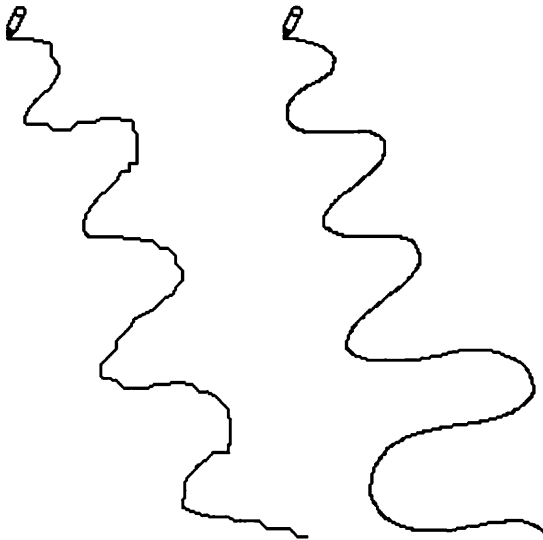

The line on the left was created by drawing quickly with the pencil tool. Notice how this produced many jags, giving the line an irregular and sloppy appearance. The line on the right was drawn more slowly and carefully. It appears more even, smooth, and professional.

If you want to improve the appearance of your lines, try drawing more slowly.



Here we have dragged the eraser tool over a black rectangle. Notice that the eraser eliminates only those portions of the black shape that it touches.

Ordinarily, the eraser tool cursor is square, like the one shown at the top of the figure above. Therefore, a series of squares the size of the cursor are erased when you drag. This is fine when you want to erase large, general areas. But if you want to delete a small or specific part of a drawing, the eraser can be clumsy or too large. You may be accidentally forced to erase adjacent objects you spent a good deal of time creating.

The solution is to erase with the pencil tool. We mentioned earlier that if you click with the pencil tool on an empty portion of your screen, you create a tiny dot. Conversely, if you click at a black or colored point on your screen, you *delete* a tiny dot. Dragging the pencil tool over an object cuts a white line through it.

If the point at which you start drawing with the pencil is empty, you create a black or colored line. If the point at which you start drawing is already black or colored, you create a white line.

Clicking with the pencil tool on a white area creates a black dot; clicking on a black area creates a white dot.

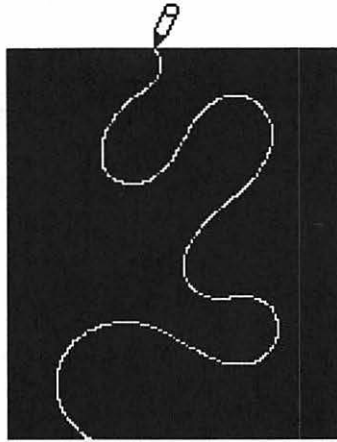

If you make a general mistake, use the eraser tool; if you make a detailed mistake, “undraw” it with the pencil tool.

Here we drag the pencil tool over a black rectangle, deleting a line as we go.

The last method for erasing produces more sweeping results than dragging with either the eraser or the pencil. It involves double-clicking on the eraser tool icon in your program’s toolbox, which deletes everything in the current window. The visible portion of your drawing is erased, but portions that are not visible remain intact. This operation is most commonly used in the early stages of the drawing process. For example, perhaps you have created a few introductory pencil marks for a sketch, only to realize that they’re entirely inaccurate. Just double-click the eraser icon and start over again.

If you make a general mistake, use the eraser tool. If you make a mistake in a small detail, “undraw” it with the pencil tool. If the visible portion of your drawing is hopelessly off-track, double-click the eraser tool icon in your program’s toolbox.

Drawing and erasing in straight lines

There are times when you may want to draw or erase in a straight vertical or horizontal line. In most programs, this is accomplished by pressing the shift key when dragging with the pencil or eraser tools.

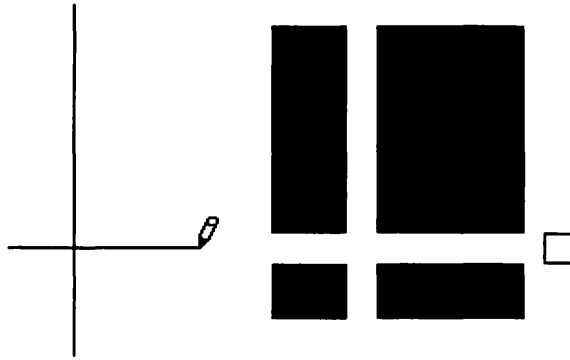

By pressing the shift key and then dragging with the pencil or eraser tool, we have drawn and erased a vertical line and a horizontal line.

By pressing the shift key, you may also constrain the results of operating many other painting tools, as we will discuss later in this chapter. This is very useful when creating geometric drawings or drawings that contain geometric objects.

Sketching with the pencil

The primary purpose of the pencil tool is sketching. When combined with the eraser, the pencil tool can be used to quickly draw and erase lines that combine to roughly represent an object.



The primary purpose of the pencil tool is sketching.

This sketch of a coffee mug was created entirely with the pencil and eraser tools. First we drew in lines to represent the mug, then we erased lines that didn't seem to belong, then we redrew lines, and so on.



Or you may create custom shapes using the polygon and freehand tools.

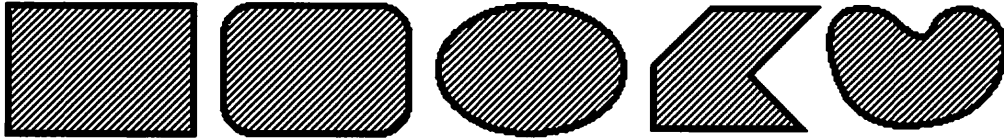

Shapes can be filled with gray values, colors, or patterns.

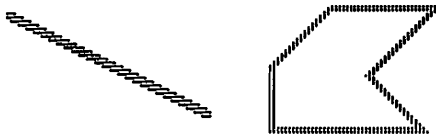

Lines and outlines can be different weights and colors as well.

You may constrain the angle of a line to a multiple of 45° by pressing the shift key.

The following pages discuss each of the line and shape tools, as well as how to apply line weights and how to edit patterns.

Creating a line or shape

The line tool is an easy tool to operate. Simply press your mouse button and drag with the line tool to create a straight line. The line begins when you click and ends when you release. Therefore, the angle of the line is determined by the angle of your drag. If you drag horizontally, you create a horizontal line. If you drag diagonally, you create a diagonal line.

You may also constrain the angle of a line to a multiple of 45° by pressing the shift key. This is similar to the method we used to constrain the pencil and eraser tools earlier in this chapter.

Straight lines may be drawn at any angle.

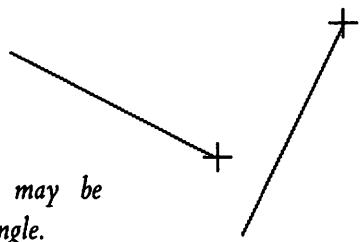

Pressing the shift key constrains your line to a 45° angle.

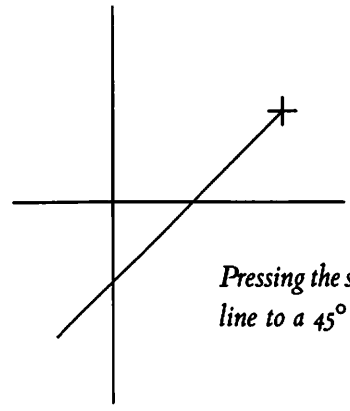

You may create a straight line by drawing with the line tool. Likewise, you may create a shape by drawing with one of the five shape tools.

Creating a shape is simply a matter of drawing with one of the five shape tools.

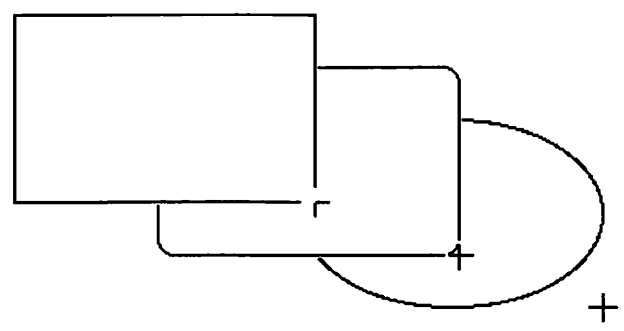

These three examples demonstrate the results of dragging with the rectangle tool, the rounded corner tool, and the ellipse tool. To operate each tool, you create the shape from corner to opposite corner. Most paint programs also provide an option that allows you to create a simple shape from center to corner, so that the beginning of your drag is the center of the shape.

Line weight is the thickness of a line. Most paint programs allow you to select from five line weights; some offer more, or allow you to design custom weights.

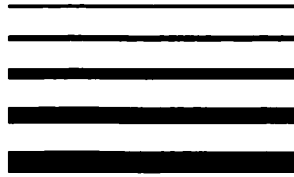

Shown above are the five most common paint program line weights. The selected weight affects only the thickness of those lines or outlines that are drawn with one of our six line and shape tools. Weights do not affect a line drawn with the pencil, eraser, or other painting tool.

Many paint applications allow you to select a separate vertical and horizontal weight component.

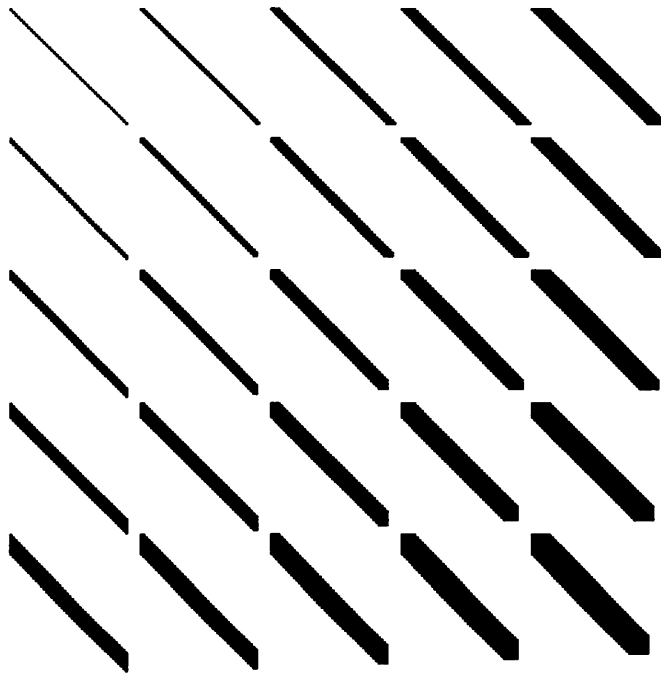

Each diagonal line above is affected separately by a horizontal and vertical line weight component. Each line in the first row is horizontally influenced by the thinnest line weight, while vertically influenced by each of the five shown in the previous figure. The second row is horizontally influenced by the second to thinnest line weight, and so on.

Many paint applications allow you to determine a separate vertical and horizontal weight component. This means that a line has one thickness if it runs vertically, another if it runs horizontally, and a combination of the two if it runs in between. The effect is similar to writing with a calligraphic pen. The only difference is that you can determine the width and height of the tip of your pen. We saw this demonstrated for diagonal lines in the previous figure. The next figure helps to further demonstrate our point.

The effect of using separate weight components is like writing with a calligraphic pen.

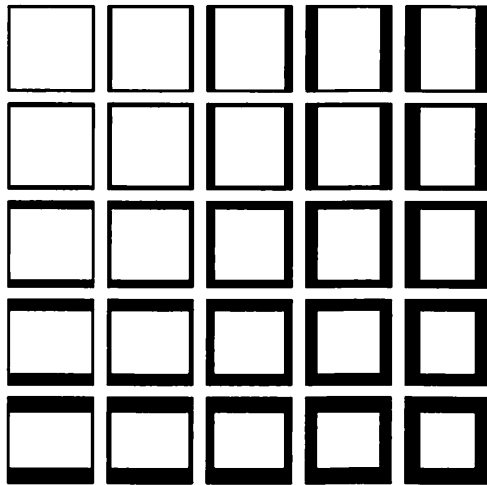

The squares and circles in these two examples are organized like the lines in the previous figure. These shapes further demonstrate the relationship between horizontal and vertical line weight components.

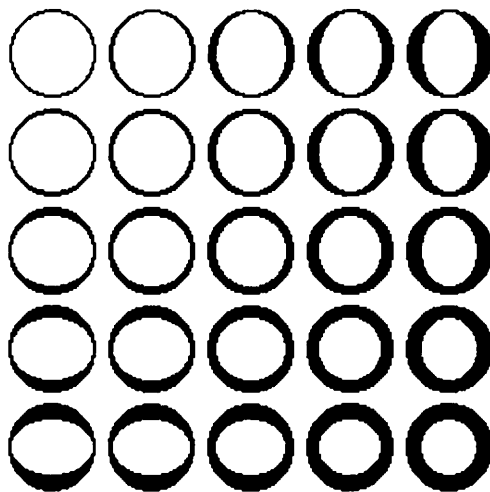

The next example demonstrates how a different vertical and horizontal weight component can combine to produce a calligraphic effect.



To produce this friendly calligraphy, we selected the widest vertical weight component and the thinnest horizontal weight component and then drew with the freehand tool. We could not have produced this result with the pencil tool or with any other painting tool that does not make use of line weight.

As it is drawn with one of the five shape tools, an element may be filled with a gray value or pattern.



Lines and shapes may be composed of a variety of weights, invoking an impression of bold character. In addition to weight, there is another attribute that distinguishes the shape tools from other tools. As it is drawn with one of the five shape tools, an element may be filled with a gray value or pattern. Even an outline or a line drawn with the line tool may be expressed as a pattern. In the following discussion, we will demonstrate how this works and how to create your own patterns.

Using gray values and patterns

A gray value is a cluster of dots that emulates a shade of gray or a lightened shade of a color. These dot clusters are then repeated throughout the interior or outline of a shape. Patterns are similar to gray values, but slightly more complicated. Rather than containing dot sequences, patterns tend to repeat a simple object or design. Examples of both gray values and patterns are shown below.



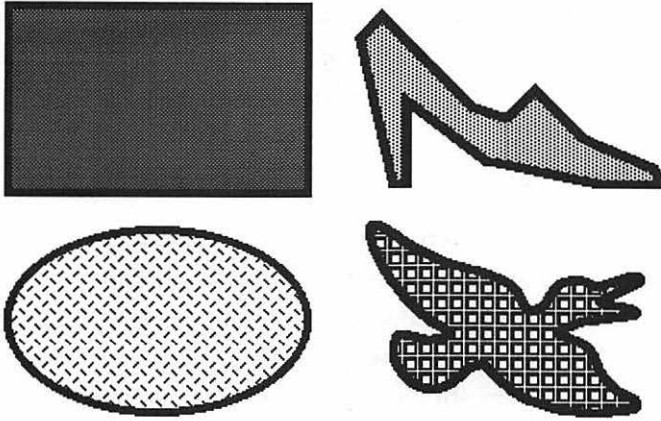

The interiors of the first two shapes are filled with gray values. The dots that make up the gray value in the rectangle are more numerous and more densely packed than those inside the shoe. The rectangle appears to be the darkest of the two upper shapes because more dots produce a darker gray value. The lower two shapes contain patterns. Notice that these patterns don't rely as much on dots as on recognizable elements, like lines and boxes. For this reason, patterns can be more conspicuous than gray values, and must therefore be used conservatively.

Gray values and patterns may also be applied to the outline of a shape.

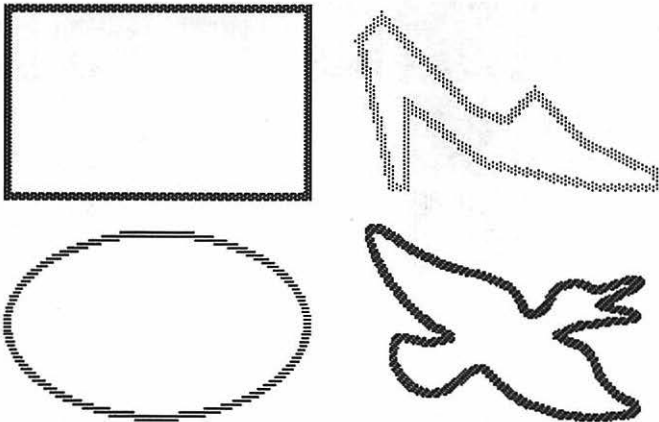

Most applications allow you to apply a gray value or pattern to the outline of a shape.

The first two shapes are outlined with gray values and the lower shapes are outlined with patterns. Incidentally, the patterns that we have selected here are fairly calm compared to some. Garish patterns work only in outlines that

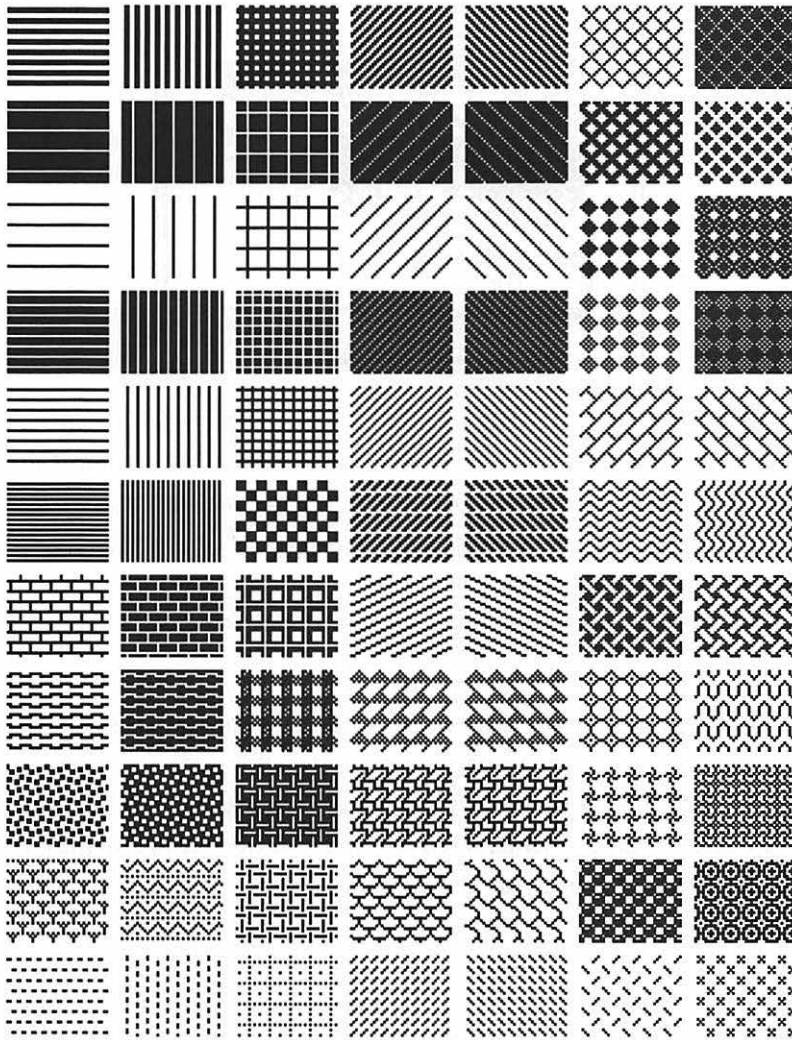

Though there are many patterns from which to choose, you may occasionally want to modify an existing pattern or create a new one.

Patterns range from the sedate to the ostentatious. Some patterns are primarily useful for shading, like those containing straight and diagonal lines shown in the top portion of the figure. Others represent real-life patterns, like bricks, fish scales, basket weave, tiles, shingles, and so on.

Despite the proliferation of patterns at your disposal, you may want to modify an existing pattern or create one of your own. Generally, this involves double clicking a pattern icon inside a palette. A dialog window will appear, allowing you to adjust the dots that make up a pattern.

The purpose of gray values and patterns is to enhance your drawings, not overwhelm them.

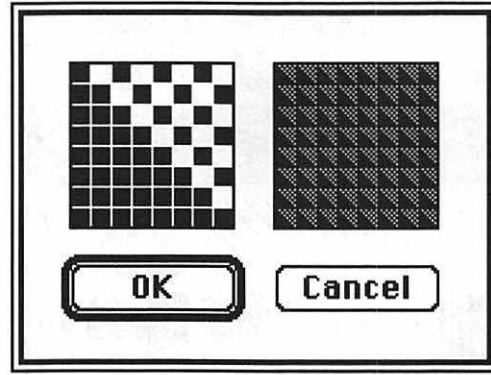

This is an example of the dialog window that appears when you double-click a pattern icon. The left view of the pattern is substantially magnified. This is the square grid of dots that will be repeated over and over to create the pattern. The right view demonstrates the actual size of the pattern, repeated several times. You alter the pattern by clicking on and off the dots on the left while observing the results of your handiwork on the right.

Try altering a few patterns before you create one from scratch. But whether altering or creating a pattern, consider not only the pattern's immediate quality—how far it will go toward impressing your viewer—but also its long-term benefits. Keep in mind that the purpose of gray values and patterns is to enhance your drawings, not overwhelm them.

Use the line tool or a shape tool when you want to create an object with a geometric appearance. These tools are also the best choice when you need to create a line or outline in a specific weight.

We demonstrated how you may alter the interior or outline of a shape by applying a pattern to it. As we'll see later in this chapter, you may fill a shape with a gray value or pattern regardless of the tool used to create it. But only the five shape tools are capable of filling a shape with a pattern while simultaneously creating the shape. With these tools, you receive immediate visual feedback while also saving a small amount of time.

Paintbrush, spraypaint, and paint can

The paint tools are most useful for creating free-form lines and shapes. They are also useful for creating special effects.

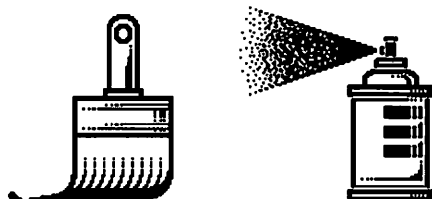

The paintbrush and spraypaint are used to create free-form lines and shapes in any pattern.



The paint can is used to fill any solid or enclosed area with a pattern.

You may alter the shape of the paintbrush cursor to draw different kinds of lines.

The following pages discuss how each tool is used and how to create special effects.

Changing brush shapes

The first tool we will discuss is the paintbrush. Like the pencil, the paintbrush is a very common tool, operated by pressing your mouse button and drawing. You may create free-form lines and shapes, just as you would with a real paintbrush on canvas. Also as with the pencil tool, you may constrain the results of drawing with the paintbrush to vertical or horizontal straight lines.

The difference between the pencil and paintbrush is that the line created by the paintbrush is typically thicker than the line created by the pencil tool. In addition, you may alter the shape of the paintbrush cursor to

draw lines of different thicknesses. The effect of changing a brush shape is similar to changing a line weight. However, brush shapes are much more diverse.

By double-clicking on the paintbrush icon in the toolbox, you produce the dialog box that allows you to select from a variety of brush shapes.

Brush shapes are more versatile than line weights, making the paintbrush tool more versatile than the freehand tool.

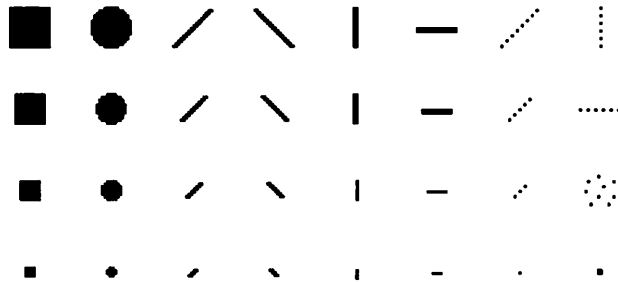

Brush shapes range from simple squares and circles of varying sizes, to diagonal and perpendicular lines, to dotted lines and shapes. Some paint programs provide a larger collection than the one shown above, and some even allow you to design your own custom brush shapes.

Just as line weights affect the line and shape tools, brush shapes allow you to control the thickness of lines drawn with the paintbrush. Brush shapes, however, are more versatile than line weights, since you can determine not only the thickness of the tip of your paintbrush but also its angle and its density (whether it is dotted or solid).

This ability to change brush shapes makes the paintbrush very versatile. You may vary the weight of a painted line, the angle of the shape with which it is painted, and the density of the line. And to increase its utility, you may paint in a gray value, a color, or a pattern, just as with the line and shape tools.

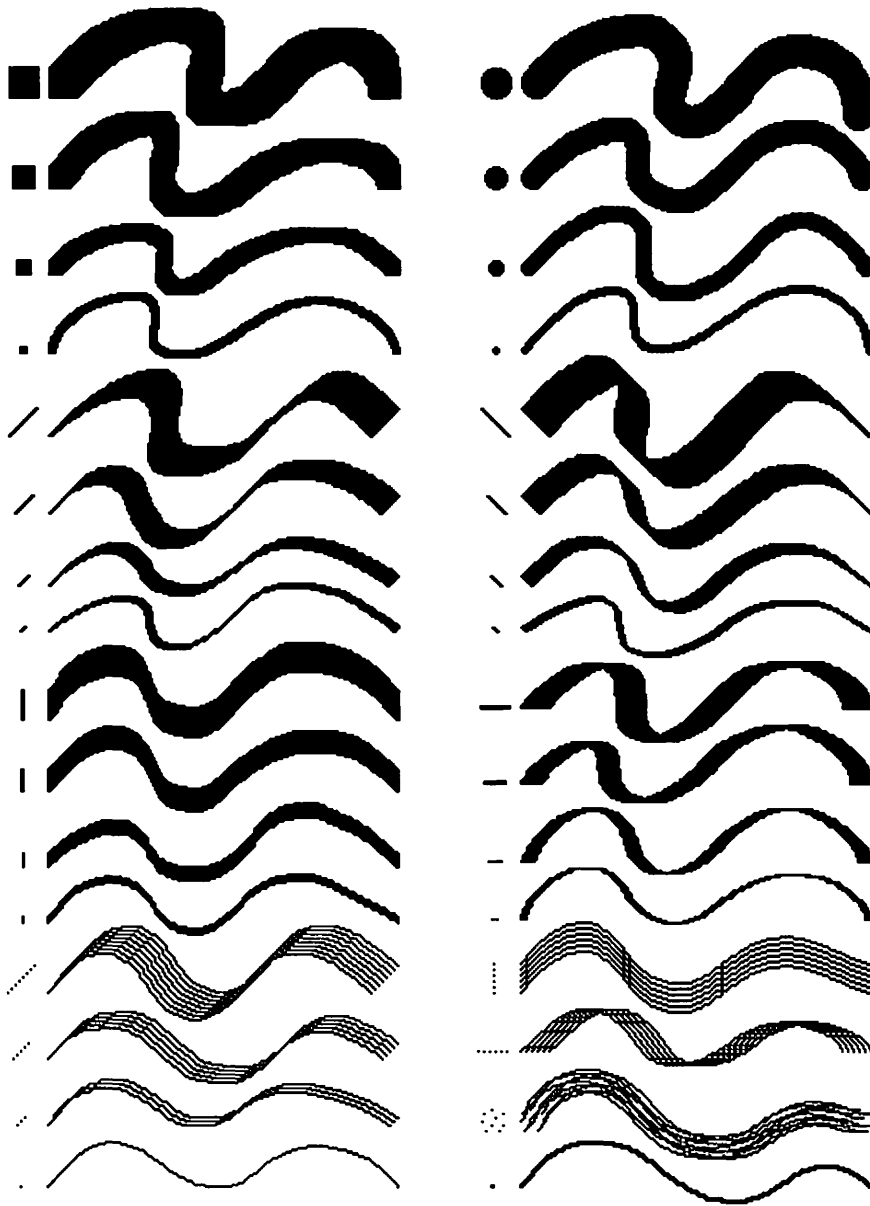

You may vary the weight of a painted line, the angle of the shape with which it is painted, and its density.

Here, we have created several wavy lines with the paintbrush tool, each drawn with a different brush shape. Notice that some of the lines in this figure could have been created with the freehand tool by altering the horizontal and vertical line weight components. Most of the lines, however—particularly those toward the bottom of the figure—could only have been created with the paintbrush.

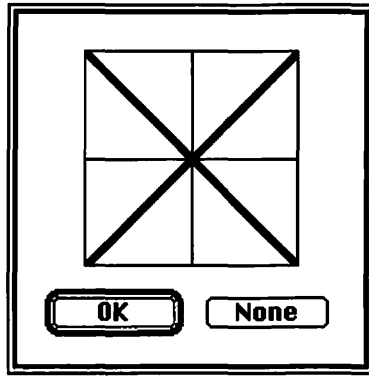

The brush mirror dialog box allows you to activate mirrors that will reflect lines created with the paintbrush tool. You may select from four mirrors—horizontal, vertical, and two diagonal—by clicking on the corresponding line in the dialog box. When a mirror is selected, its line becomes heavier. In the figure above, we have selected the two diagonal brush mirrors. To deactivate a mirror, click on it again, and the mirror line becomes lighter.

After you have determined which mirrors are currently active, you may use the paintbrush tool to create kaleidoscopic special effects.

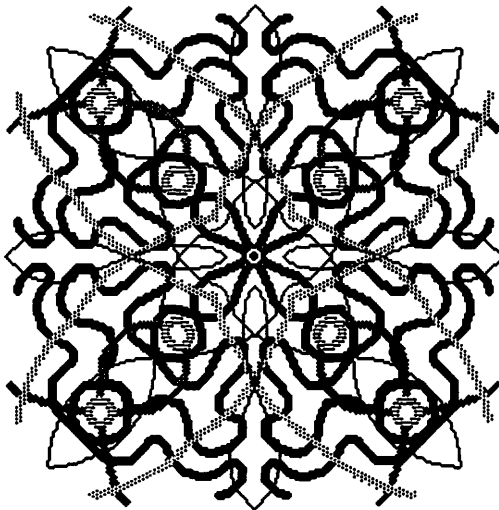

Brush mirrors are useful for creating kaleidoscopic effects or symmetrical objects.

Since we selected the two diagonal brush mirrors, every paintbrush stroke was reflected in the upper left, upper right, lower left, and lower right quarters of our drawing. The center of the figure is where the two brush mirrors intersect. Here we have drawn several lines using a variety of patterns and brush shapes.

If you want to create dark, heavy forms, draw slowly with the spraypaint tool. If you want to create lighter, more billowy elements, draw quickly or use a lighter pattern.

Spraypainting with a pattern

The spraypaint squiggles shown in the previous figure were created while the solid black pattern was selected. But you may also spraypaint in a gray value, color, or pattern. Like the paintbrush, the spraypaint tool always paints in the currently selected pattern.

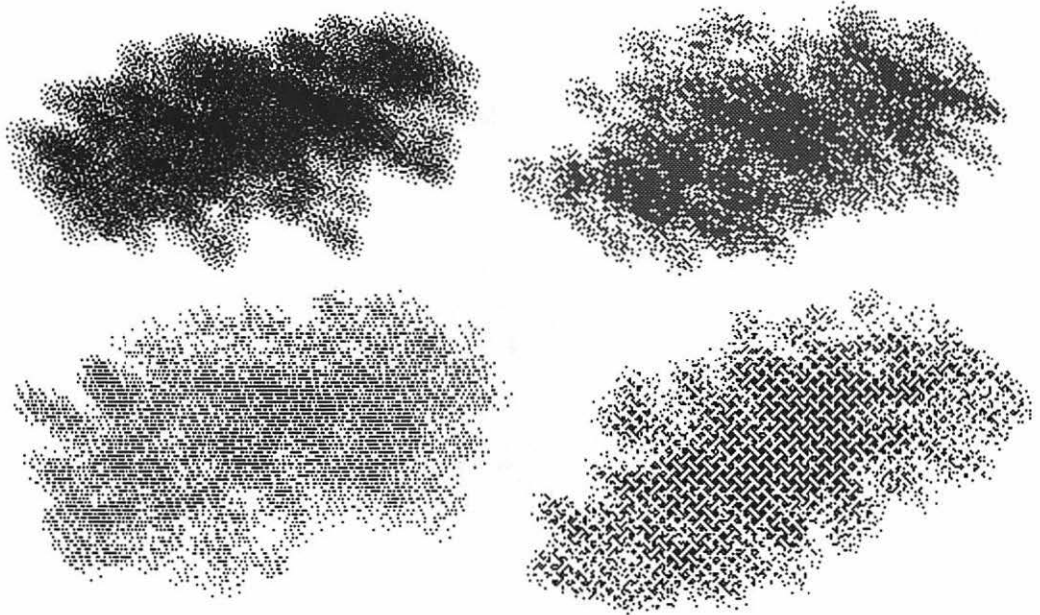

Each of these four clouds was created with the spraypaint tool in a different gray value or pattern. We drew each cloud at about the same speed; any variations in lightness or darkness are due to the patterns themselves.

The spraypaint tool permits you to control the density of garish patterns.

A pattern is especially useful when drawing with the spraypaint tool, because the tool permits you to control the density of the pattern, to fade in and out. This produces a subtle hint of the pattern, which—especially in the case of the more elaborate patterns—does not overwhelm other elements of your drawing.

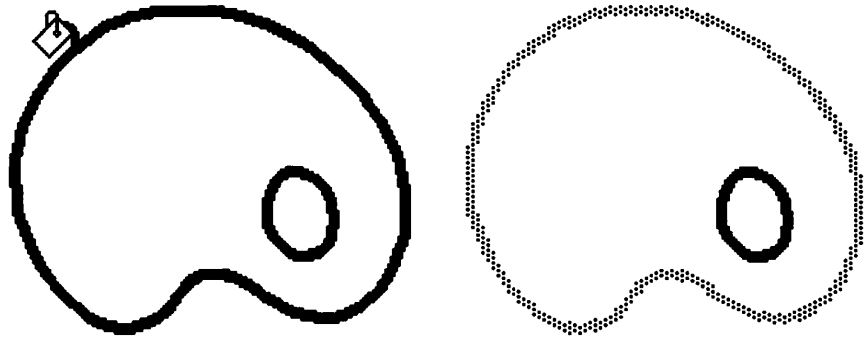

By clicking with the paint can on a solid portion of a shape, such as the outline in the figure, you substitute the selected pattern for the solid color.

The paint can's primary purpose is to change the interior or outline of a shape to a pattern after the shape has already been completed. Thus, it is an important tool for changing the appearance of an enclosed or solid area of an existing image.



Only by understanding patterns can you fully master each of the three paint tools and brush mirrors.

Use the paintbrush if you want to create a free-form line in a gray value, color, or pattern. The paintbrush is also useful when you want to control the shape of your cursor to affect the thickness of a line. If you want to create an airbrush or shading effect, use the spraypaint tool.

Brush mirrors should be employed whenever you want to create a symmetrical image, or an image with a proportional reflection or shadow. Using brush mirrors properly cuts your working time by at least half.

And finally, if you are unhappy with the interior of a shape or its solid outline, you may fill it with a gray value, color, or pattern by clicking on it with the paint can tool.

All three paint tools work directly with the currently selected gray value, color, or pattern. Therefore, only by understanding patterns, as discussed earlier in this chapter, can you fully master each of the three paint tools and brush mirrors.

This is a block of text in a typical paint application

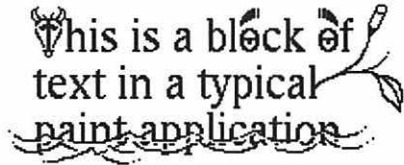

This is a block of text in a typical paint application



After it is created, text is a standard graphic element than can be erased, enhanced, filled, or transformed.

You cannot go back and fix a typo or otherwise edit existing bit-mapped text.

Also, bit-mapped text is not editable. After you have created a block of text, you cannot go back later and fix a typo or change the type size or make a word italic. If you want to reformat a block of text, you have to create it again from scratch and apply formatting as discussed in the next few pages.

A few paint applications provide access to both bit-mapped and editable text, the latter of which prints smoothly to a laser printer or type-setter. However, this editable text cannot be manipulated using paint tools or any special effects command, since it is not a traditional graphic element. So even using these programs, there is a trade-off: create text that can be graphically manipulated but will appear bit-mapped when printed or create text that is editable and prints smoothly but cannot be graphically manipulated.

Since most paint applications do not feature editable text, the following pages focus on creating text as a graphic element. For information on specific applications that offer editable text, see Chapter 10.

Entering type from the keyboard

To create a block of text, click with the type tool at the point in your graphic where you want your text to begin. A blinking text entry cursor will appear where you have clicked, indicating that the application is ready for you to begin typing.

As you enter text from your keyboard, the characters will appear on your screen. The text entry cursor moves as you type, always indicating the location of the next character. If you make a mistake, some programs allow you to move your text entry cursor within a text block by pressing the one of the cursor arrow keys (↑, ←, ↓, →, not included on Mac Plus or earlier keyboards). This useful feature allows you to move the text entry cursor back to the location of a mistake and fix it without altering any correct text. However, many paint applications do not recognize these keys, requiring you to press the backspace or delete key to delete every character between your present position and the mistake and re-enter the text from that point.

Now iz the time for every good|

Now i|

Now is the time for every good person to vote.

If you notice a typographic error while entering text, you must backspace all the way back to the typo and enter the deleted text again.

Also, most applications do not allow you to indicate column widths for bit-mapped text. Instead, you must press the return key to begin a new line of type.

If at any time while entering text you so much as click your mouse button in the application window or select a different tool, your text will become inactive and you will no longer be able to edit it. As long as you avoid either of these actions, your text entry cursor will continue to blink at the end of your text block, indicating that the text remains active. And only active text may be formatted using your program's type commands.

When entering text from the keyboard, you must press the return key to begin a new line of type.

The variety and number of fonts available in your paint application is determined directly by the contents of your System file. Fonts can be added to or deleted from your System file using Apple's Font/DA Mover utility. For complete information on configuring your System, consult your Macintosh owner's manual.

You may also choose from a variety of type styles—as determined by your paint application—to alter the appearance slightly of the current typeface. “Plain” is the normal type style, and should be chosen if you want the font to appear “as is,” unaltered in any way. “Bold” and “Italic” are common variations of a font, often included as part of the typeface family. For example, Times Roman is the plain style of the font Times. Times Bold and Times Italic are separate typefaces but are part of the same type family. It is also possible to combine “Bold” and “Italic,” in this case creating Times Bold-Italic. If no bold or italic style is specifically designed for a typeface—for example, the Chicago family includes only plain Chicago—the paint application will improvise the style, fattening type to make it bold or slanting it to make it italic.

Plain
Bold
Italic
Bold Italic
Underline
Outline
Bold Outline
Shadow
Outline Shadow
Bold Outline Shadow

*Type styles can
be used to enhance
the appearance
of a typeface.*

Above are combinations of type styles available in most paint applications. Any style can be applied to any font; every style, except for “Plain,” can be combined with another style.

Other type styles available in most paint applications include “Underline,” “Outline,” and “Shadow,” none of which rely on type family definitions but are instead applied to any typeface by the paint application itself.

Type size determine the height of the letters in a text block. Size is measured in points, tiny units of measure equal to $\frac{1}{72}$ of an inch. Size availability typically ranges from 9-point to 48-point, or $\frac{1}{8}$ -inch to $\frac{2}{3}$ -inch. You will notice that some type size commands are outlined, rather than solid black. These outlined numbers correspond to the screen font sizes of the current typeface that are loaded into your System file. In other words, your text will look best at these sizes when formatted in this typeface.

Type size is measured in points, a tiny unit of measure equal to $\frac{1}{72}$ of an inch.

48-point

9-point

10-point

36-point

12-point

14-point

24-point

18-point

18-point

24-point

14-point

12-point

36-point

10-point

9-point

48-point

Shown here are the most common type sizes offered by a paint application. Each size is shown in the font Helvetica, left, and Times, right, for comparative purposes. In our menu, all sizes except 36- and 48-point were displayed as outlined numbers. This is why the two largest type sizes in the figure look more jagged than the smaller ones.

The fourth category of text formatting in paint applications is line spacing, or leading, which is the amount of vertical space between one line of type and the next in the same text block. Typically, a paint application only allows you to choose from single, 1-1/2, and double spacing, although some offer no spacing choices at all.

This text block is spaced normally, or single-spaced.

This text block is spaced 150% of normal.

This text block is spaced twice normal, or double-spaced.

Show above are examples of single-spaced, 1 1/2-spaced, and double-spaced text blocks. If your application does not offer spacing commands, your text blocks will automatically be single-spaced.

The last formatting category is alignment. Alignment determines the relative positioning of each line of type in a block of text. Type is aligned in reference to where you originally clicked with the type tool when creating the current text block. Your click location determines the leftmost point of type that is aligned left, the rightmost point of type that is aligned right, and the center point of type that is aligned middle.

This text is ragged right or flush left.

This text is ragged left or flush right.

This text is aligned middle or centered.

Text is aligned in relation to where you originally clicked with the text tool.

Type in a typical paint application may be flush left, flush right, or centered.

Create only small amounts of large display text in a paint application.

Font, style, size, spacing, and alignment work together to determine the basic appearance of your text block. Each formatting category can only be applied when a block of text is active, or when the text entry cursor is blinking. After a text block is formatted, you can further manipulate the text block using any of the graphic tools discussed earlier in this chapter.

Generally, we recommend that you enter only small amounts of display text in a paint application. Large amounts of body copy text should be input in a word-processor, since bit-mapped text is generally difficult to read.

We also recommend that you use large type sizes, 24-point and higher. If you go any smaller, stick to sizes that are outlined in your type menu.

Remember that the only advantage to text in a paint application over text created in a word-processor is that it may be graphically manipulated. You can come up with many surprisingly attractive effects by altering bit-mapped type with the other tools we have discussed so far. Or you may apply any of the transformation commands that we will discuss in the next section.

Lasso and marquee tools, basic commands

Regardless of what tool you used to create it, any graphic element in a paint application can be moved, copied, or otherwise manipulated. But to manipulate the element, it must first be selected. The lasso and the marquee are the two common tools that allow you to select and manipulate elements.



The sole purpose of the lasso and marquee tools is to select and manipulate existing graphic elements.

The following pages describe how these tools are used, including how to select, move, clone, copy, and apply several other popular commands.

Using the lasso tool

To select an existing line or shape with the lasso tool, you simply press your mouse button and drag around the perimeter of the element.

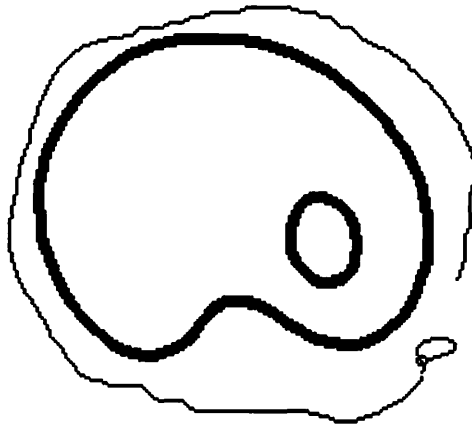

*A selected element
may be moved,
copied, and
transformed.*

When you drag with the lasso tool, you create a lasso. After you release your mouse button, all black or colored dots surrounded by the lasso become selected. Make sure that your lasso completely surrounds the graphic element that you want to select.

All portions of an element or elements that are selected with the lasso tool will vibrate on your computer screen. If any portion of an element does not vibrate, it is not selected.

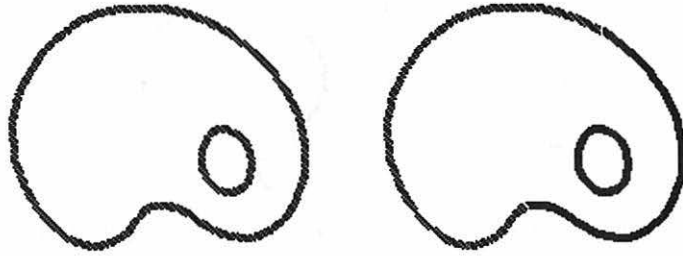

The shape on the left is completely selected, since its entire outline is vibrating. The right-hand element is only partially selected; the portion of the shape's outline that is still black is not selected. In the enlarged detail of the right-hand element displayed below, the selected area is highlighted.

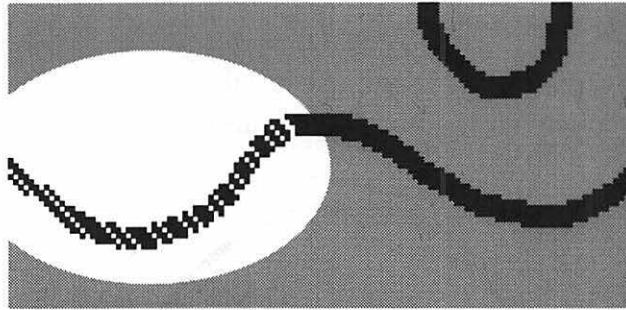

You may move an object by selecting it and dragging at its outline.

After you select a line or shape, move it by pressing your mouse button and dragging at its outline. If you move a selected element into an area already occupied by another element, the selected element will appear in front of the stationary element. The stationary element will then be covered by any black or colored portions of the selected element, as well as any white areas of the selected element that are completely enclosed.

Some applications allow you to double-click the lasso tool icon in your toolbox to lasso all elements displayed in the current window.

Objects are selected by drawing a lasso around them with the lasso tool. Selected objects may then be moved by dragging at their outlines. If you want the interior of a shape to be opaque, make sure it is completely enclosed. If you want the interior to be transparent, create a break in the shape before lassoing it.

Use the lasso tool to select a specific shape or portion of a shape and any enclosed interiors.

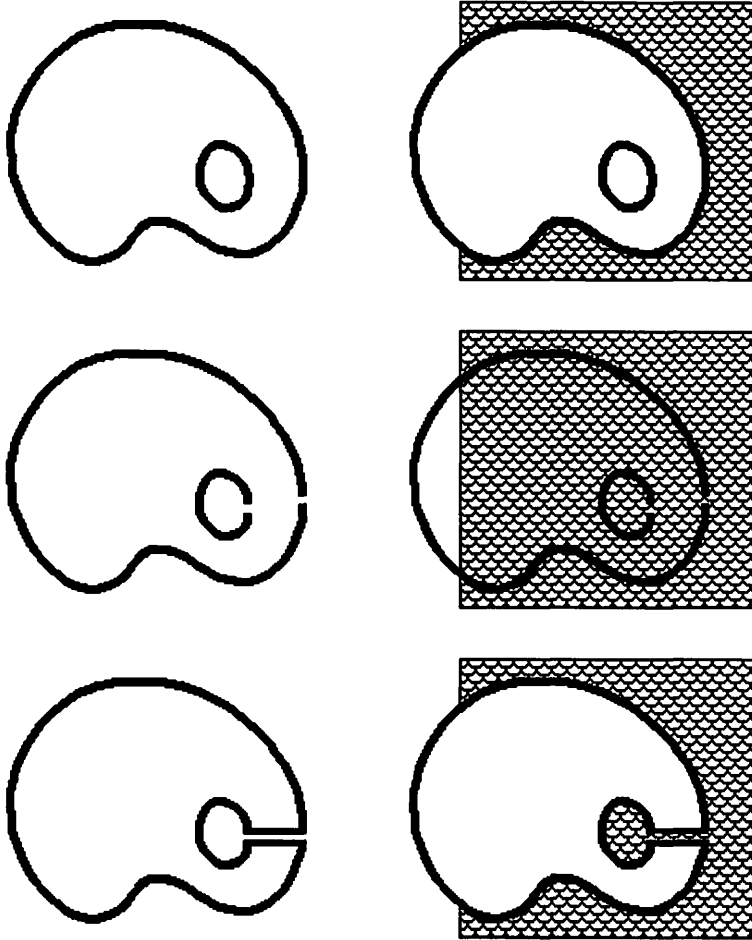

In the figure above, we have selected each of the three elements on the left with the lasso tool and moved them onto the pattern-filled rectangle on the right. The results vary according to whether or not the white areas inside of the selected shapes are completely enclosed. In the top example, the interior of the shape is fully enclosed, so the white area is also selected, covering the pattern-filled rectangle. In the middle example, there are breaks in the outline of the shape. Its interior is not selected but is instead transparent. In the bottom example, the white area inside the outer shape is enclosed while the inside of the smaller shape is not.

The lasso tool is used to select a specific shape or portion of a shape. To select a more general area, use the marquee tool.

Using the marquee tool

The marquee tool is operated similarly to the rectangle tool, described earlier in this chapter. You press the mouse button and drag from corner to opposite corner, around the image that you want to select. As you drag, a rectangular, dotted marquee is created. The entire area inside this marquee becomes selected, including all white areas.

To move an area selected with the marquee tool, press your mouse button and drag anywhere inside the marquee.

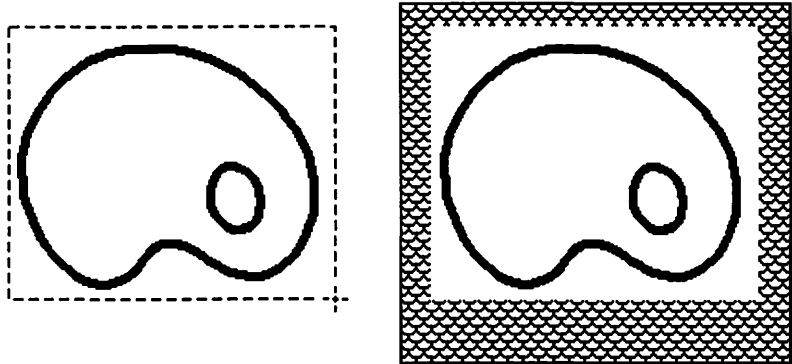

In the first example, we selected our shape using the marquee tool. A dotted marquee appears around the shape, indicating that it is selected. In the right example, we move the marquee area in front of the pattern-filled rectangle. Since all of the white areas inside the marquee are opaque, a white rectangle surrounds our shape.

Pressing the command key shrinks a marquee down to the smallest rectangle that will hold a selected element.

In most paint applications, you may reduce the amount of extraneous white space that you select by pressing the command key (⌘) while marqueeing an element. After you release the mouse button, the command key causes your marquee to shrink down to the smallest rectangle that will hold all surrounded black and colored dots.

Tracing the edges of an element gives it a ghostly or outlined effect.

Rotate an object when you want to change its angle by 90° . This is especially useful if you want to turn an image upside-down or otherwise experiment with its positioning. If you want to create a mirror image of an object to create a shadow or reflection, choose the “Flip horizontal” or “Flip vertical” command. Scaling is useful if you originally created an object at the wrong size or if you want to create an enlarged or miniature version of an object. You can also make objects fatter or thinner using scaling.

The next few transformations we will discuss fall into the special effects category. These commands dramatically change the appearance of an object.

Tracing edges

Another transformation that can only be performed on a marqueeed element is the “Trace edges” command, included in most paint applications. This command draws a thin outline around each side of the lines in your marquee.

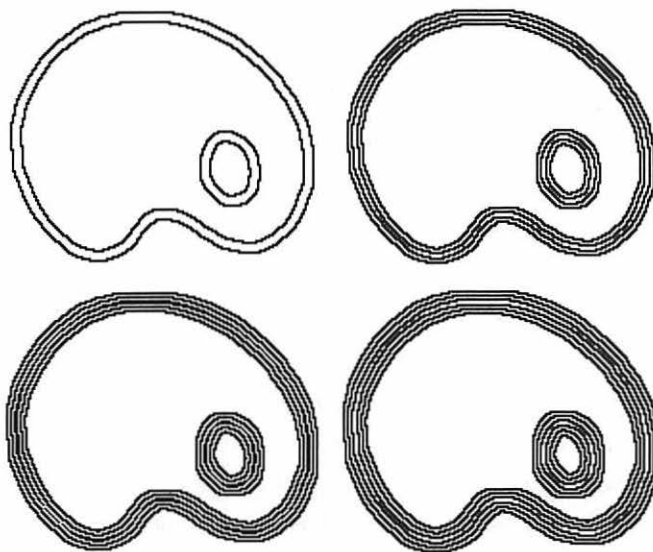

In the top left example, we have applied the “Trace edges” command to a simple object, producing a clean outline tracing around the interior and exterior of the two shapes. You may often achieve interesting results by

Depending on the manner in which an object is selected, the “Invert” and “Fill” commands will produce different effects.

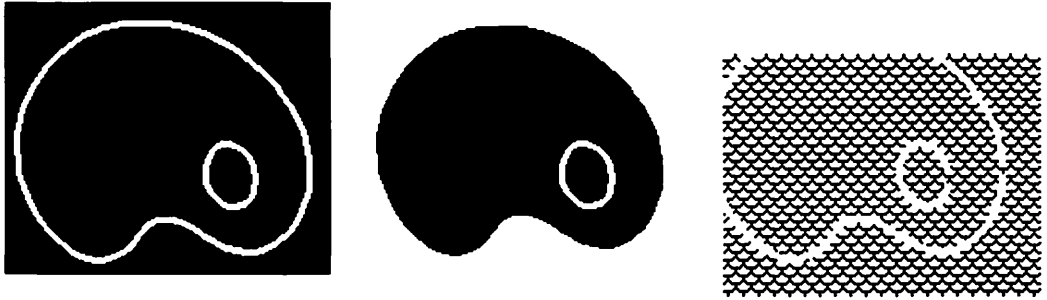

In the first example, we have inverted an object selected with the marquee tool. Notice that the white area outside of the shape but surrounded by the marquee has been inverted as well. In the second example, we have inverted the same object selected using the lasso tool. The larger outline seems to have completely disappeared, since it has turned white against a white background. In the third example, we have lassoed shapes with breaks in their outlines. Since no white area is selected, nothing is turned black when we invert the image. In fact, the selected object would be entirely invisible if we had not moved it in front of a patterned background.

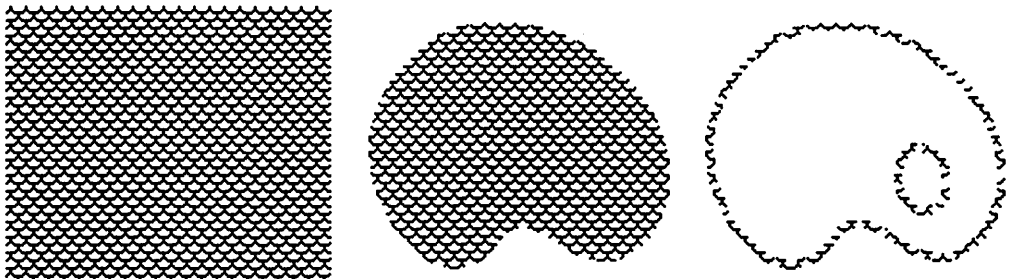

Filling a marquee'd object is not generally very successful, since the entire marquee becomes filled as demonstrated in the first example. In the second example, we have filled an object selected with the lasso tool, the interior of which is fully enclosed. Notice that the interior, as well as all black lines in the shapes, are filled with the current pattern. In the final example, we have lassoed an object with breaks in its outline. Since there is no enclosed interior, only the formerly black outline is filled.

The “Invert” command is useful for creating negative images of a selected object. There are often times when you want to create a black and white drawing where the white images are easier to create than the black. In such a case, you may draw the white image initially as a black image, and then invert it.

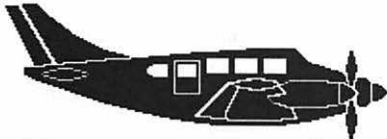

Peace in the air...



Peace in the air...

In the illustration above, we found that it was easiest to create the plane and its accompanying text as black objects. We then inverted them both, and set them against a black background that we created separately.

You may wonder why the “Fill” command even exists, particularly when the paint can is so easy to use. The primary advantage of using the “Fill” command instead of the paint can is that you may fill many separate elements at the same time.

The “Fill” command can be used to fill many separate elements simultaneously.



By lassoing the text shown above, we were able to fill each letter at the same time. If we had used the paint can, we would have had to fill each letter separately.

You can also create interesting partial fills by lassoing only a portion of an object.



You can create partial fills by lassoing open portions of an object and applying the “Fill” command. We utilized this technique three times to create the image on the right of an airplane passing through clouds shown. This technique would be impossible if we had used only the paint can.

The “Invert” and “Fill” commands are useful transformation methods, producing very different effects depending on how an object is selected, and both commands are available in almost every paint application. The next commands we will discuss are also very powerful, but they are not quite as widely available.

Advanced special-effects commands are only available in high-end paint applications.

Advanced special effects

The “Free rotate,” “Slant” (or “Skew”), “Perspective,” and “Distort” commands are not available in every paint program, but they are very powerful features. Each command is generally applicable only to objects selected with the marquee tool.

Choosing any one of these commands changes your standard marquee into a customized marquee with a handle at each corner. These handles may then be dragged depending on the nature of the command chosen.

The “Free rotate” command allows you to drag a handle in a clockwise or counter-clockwise direction to rotate the selected object in single degree increments. If you choose the “Slant” or “Skew” command, dragging at a handle will slant your shape. By pressing the shift key, you may constrain your drag to produce a purely vertical or horizontal slant.

The “Perspective” command allows you to apply perspective to an object, as we discussed in the *Demonstrating depth* section in Chapter 2. If you drag at a handle after choosing the “Perspective” command, you may increase the height or width of one side of an object without affecting the

other. By pressing the shift key, you ensure that both corners on one side of the object will move in equal and opposite directions.

The “Distort” command enables you to drag at any handle of the marquee, discriminably stretching an object in that direction. It is as if the object were transposed to a piece of silly putty, where you could then stretch and misshape it.

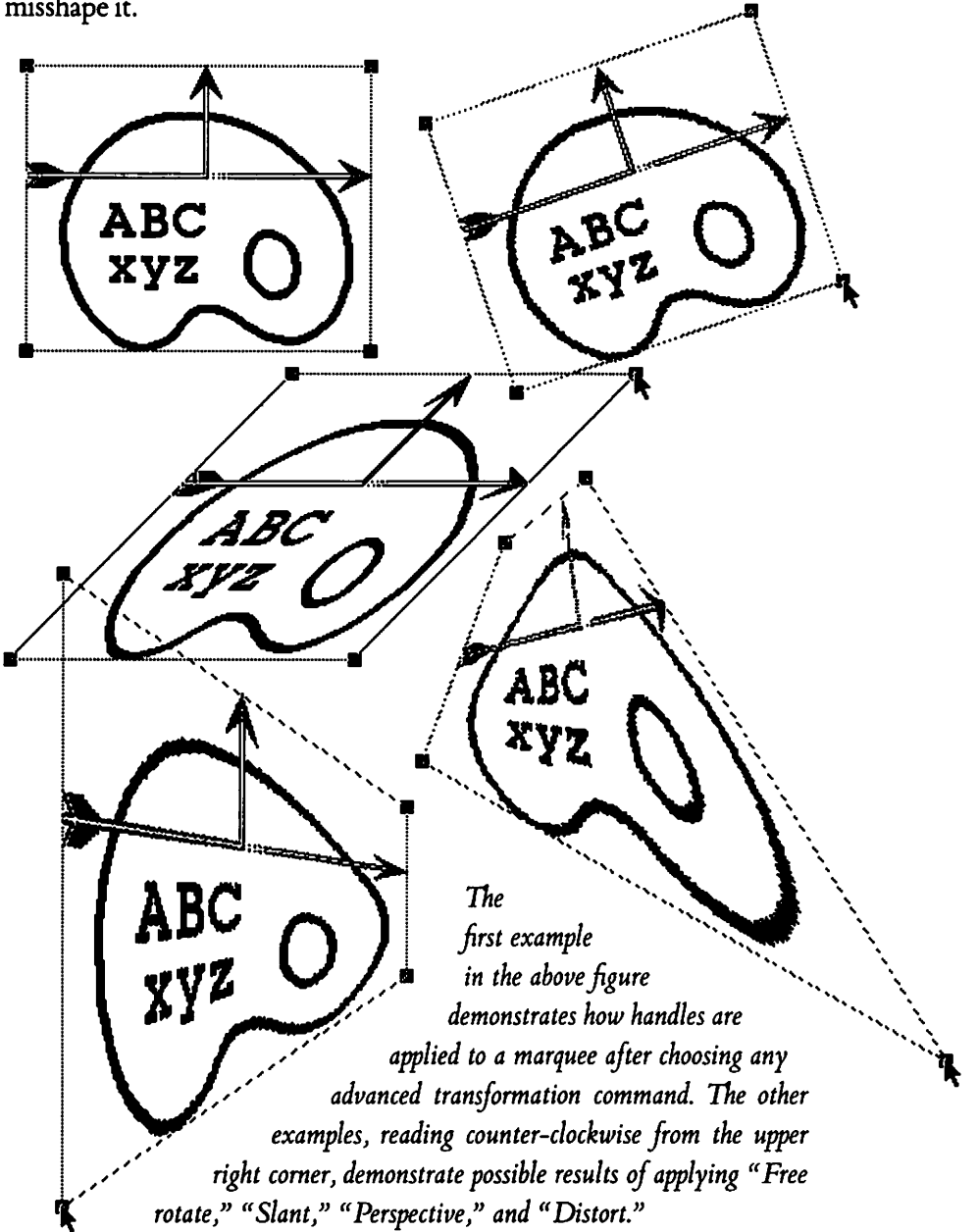

Each of these powerful special effects commands performs an irregular transformation on the selected object. As you can see in the previous figure, after the transformation is complete, the affected element is often ragged-looking. It is difficult for your paint application to both obey your directions and produce an aesthetically appealing result. Therefore, you will frequently have to clean up an object after transforming it with one of these commands.

This ends our discussion of transformation commands. The following pages discuss operations that create duplications of a selected object. Duplication techniques may be performed on elements selected with either the lasso or marquee tools.

Cut, copy, and paste

The “Cut,” “Copy,” and “Paste” commands are available in any Macintosh application. Each command works with Apple’s built-in Clipboard, where a single image at a time is stored for temporary retrieval. Each command may be performed on any selected object, whether lassoed or marqueeed.

Together, the three commands are useful for creating copies of an object. The “Cut” command removes the selected element from your graphic and places it in the Clipboard, thereby displacing the Clipboard’s previous contents. The “Copy” command also replaces the Clipboard’s current contents, but without removing the selected element from your graphic. The “Paste” command retrieves a copy of the Clipboard contents and imports it as a selected element into your graphic.

The “Paste” command may also be used to scale an object as it is imported. If an element is currently lassoed or marqueeed when you choose “Paste,” the Clipboard contents will replace the selected element, enlarging or reducing to match the original element’s dimensions.

*The “Paste”
command may
be used to scale
an object as
it is imported.*

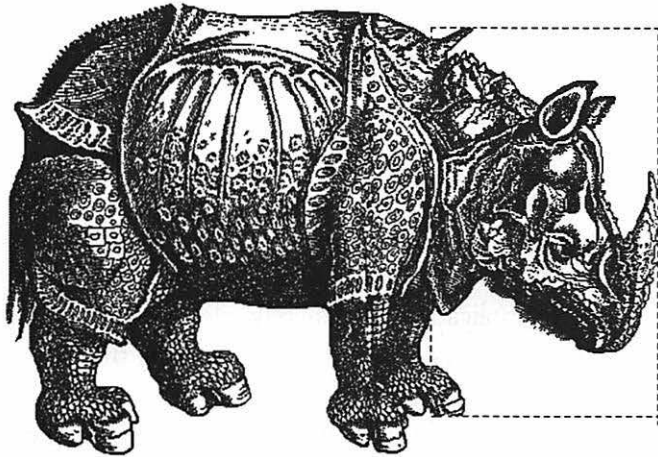

*“Cut,” “Copy,”
and “Paste” can
also be used to
transfer objects
between different
paint files.*

Here we select a portion of a large graphic and choose the “Copy” command.

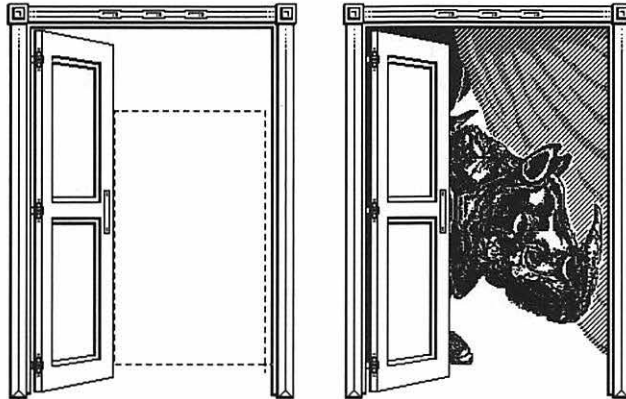

We then move to a different portion of our paint file, which contains the image of a doorway. Since the doorway is quite a bit smaller than the contents of our Clipboard, we intend to paste and scale our creature at the same time so that it appears to be peeking out from behind the door. We marquee the area shown in the left example and choose “Paste.” The creature automatically scales down to fit in the marquee. After completing our “Paste” operation, we add a background to enhance the image, as shown on the right.

The “Cut,” “Copy,” and “Paste” commands can also be used to transfer objects between different paint files.

If you want to create a copy of an object without copying and pasting, there is a quicker way known as cloning.

Cloning and drawing with an element

To clone an object is to create a quick copy of it without using the Clipboard or displacing its current contents. Clones are very simple to create in almost every paint application. You merely select an object with either the lasso or marquee tool, press the option key, and drag the selected object to a new location. Pressing the option key allows for one copy of the object to remain at its original location while the other selected copy is created at the point where you release your mouse button.

Pressing the option key allows you to create one clone for every time that you drag and release your mouse button.

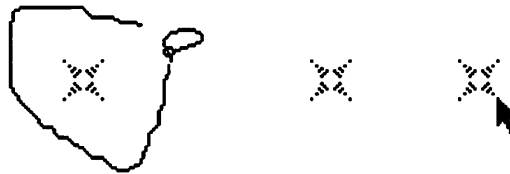

After lassoing an element, we press the option key and drag it to create a clone.



Or we may marquee the element and option-drag to produce the same results.

Cloning is a useful and efficient technique for creating multiple copies of objects. Each clone may then be separately transformed, depending on your personal graphic requirements.

Pressing the option key allows you to create one clone for every time that you drag and release your mouse button. If you simultaneously press both the option and command keys, you can create a constant stream of clones that follows the course of your drag. This is similar to customizing a brush shape, as we mentioned in the *Paintbrush*, *spraypaint*, and *paint can*

section earlier in this chapter. Unfortunately, many programs do not allow you to customize a brush shape. But almost every paint application lets you command-option-drag a selected shape, to produce very similar results.

Pressing both the command and option keys allows you to draw with a selected element as your cursor.



By pressing the command key while marqueeing a shape, we shrink the marquee to the exact boundaries of the object. This is an essential prerequisite to drawing with a marqueeed object. After command-marqueeing, we command-option-drag the element. Notice in the figure that only those portions of the selected element that touch the edge of the marquee appear to repeat, creating a streaming effect. This is why it is so important to command-marquee an object, so that the edge of the marquee is not entirely white.

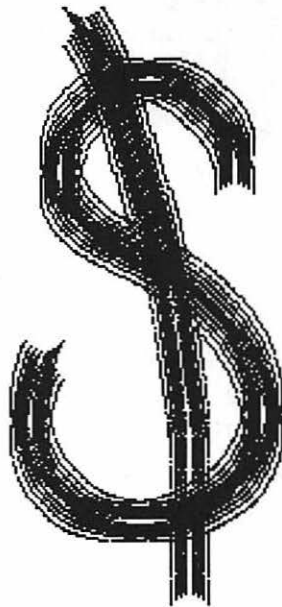

If you really want to draw with an object, you should select it with the lasso tool.

Pressing the command and option keys effectively allows you to draw with an object, regardless of its size, as if the selected object were a tool you could select from your toolbox. The results of command-option-dragging vary depending on whether the object was selected with the marquee or lasso tool.

The speed at which you draw also affects the appearance of your graphic. If you command-option-drag slowly, the clones will be tightly packed together. If you command-option-drag quickly, you can produce a spraypaint effect with the selected element.

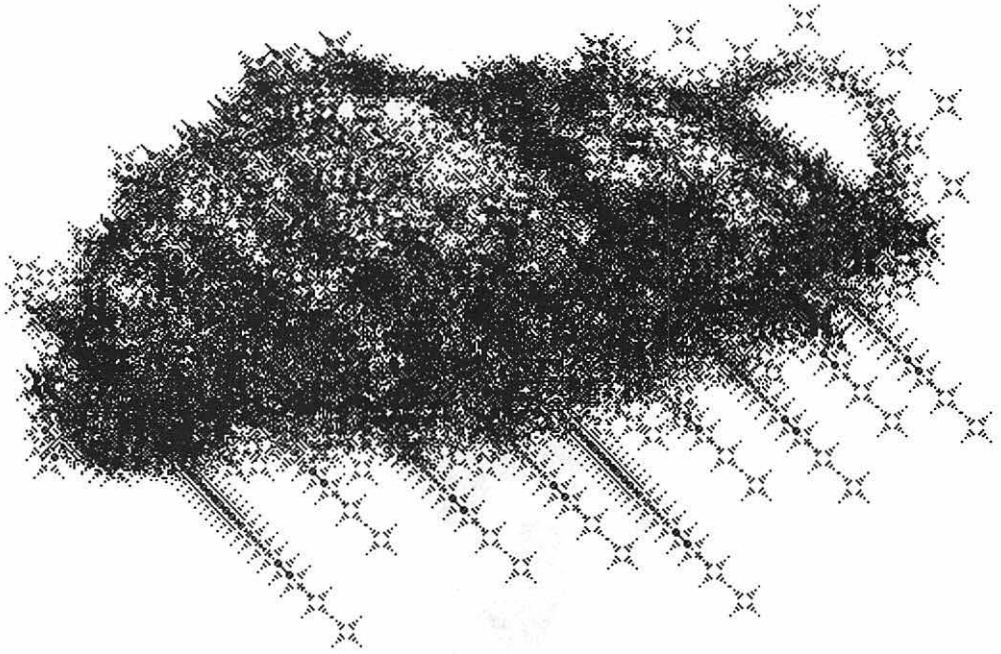

This rain cloud was created by command-option-dragging very quickly. We sketched out the form of the cloud first, and then separately created the sunshine and other elements. The trails of rain emanating from the cloud were created by pressing the shift key as well as the command and option keys, constraining our quick swipes diagonally.

Command-option-dragging a marqueeed element creates a streamer effect. If an element is lassoed, you can draw with it slowly, to create a paintbrush effect, or quickly, to produce a spraypaint effect. You may use this method to draw with elements of any size or complexity. We recommend, however, that you apply this technique to small, simple objects.

Objects may be selected using either the marquee or lasso tool. A selected element may then be moved by simply dragging it to a new location.

Selected elements may also be transformed. Most transformation commands, such as rotating, flipping, scaling, or tracing edges, require that an object be marqueeed. Some operations, however, such as inverting and filling, allow you to transform either a marqueeed or lassoed element.

You may also duplicate a selected element, regardless of how it is selected. The “Cut,” “Copy,” and “Paste” commands allow you to transfer elements to different paint files or to resize them as they are pasted. Or you may option-drag to create a quick clone. Finally, pressing both the command and option keys allows you to draw with a selected element.

This completes our discussion of creating and manipulating graphic elements. The last section of this chapter discusses how to get around in the paint environment, and how to fine-tune your drawing efforts.

*You may magnify
or reduce the
appearance of your
graphic using
the zoom tools.*

View sizes and the grabber tool

Paint programs provide two ways to manipulate the way you see your paint graphic on-screen. The zoom tools make it possible to magnify the view size so that an image appears larger or smaller in the application window. The grabber hand allows you to move an image with respect to the application window.

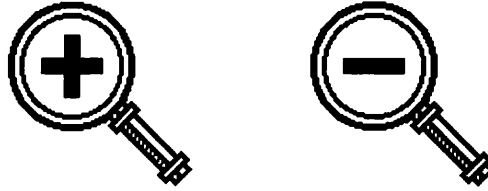

Clicking with one of the zoom tools enlarges or reduces the dots in your graphic.



Dragging with the grabber hand moves your illustration within the paint application window.

The remaining pages discuss the uses and purposes of each tool.

Zooming, using the pencil in fat-bits

All paint applications offer view sizes. Generally, you may magnify the on-screen display of your graphic to two times, four times, and eight times its normal size. Some applications allow you to access even higher magnifications. You may also demagnify the view size so you can see the entire page, typically a 50% view size.

“Fat-bits” is useful for individually viewing each square pixel in your graphic.

However, the method by which you access these view sizes varies widely among different applications. Some applications contain a magnifying tool in the application toolbox. Others allow you to choose view sizes as commands from a menu. But the most common method is to press the command key and click with the pencil tool to magnify the display of your graphic, or press the shift and command keys and click with the pencil tool to zoom out from the page. We recommend that you consult your software manual to familiarize yourself with the method that applies to your paint application.

vidually. You may then manipulate these dots, adding them or removing them using the pencil tool. A small superimposed window is also generally provided, displaying your graphic at normal size for reference.

Magnifying the view size reduces the amount of the graphic you can see at a time. Whereas your graphic may easily fit into your screen display at the normal view size, only a small portion is visible in “fat-bits.” The grabber hand allows you to move about to different portions.

Moving the graphic with respect to the window

The grabber hand allows you to drag the page in reference to the application window.

Depending on the dimensions of your monitor, you probably cannot see all of your page on-screen at the same time. Even if your graphic is entirely visible on-screen when viewed at normal size, there are times when you may want to magnify the view size, decreasing the visible area of your graphic. The grabber hand allows you to drag the page in reference to the application window, to determine which portion of your graphic is visible at any one time.

In some applications, you access the grabber hand tool from the application toolbox. But usually you either press the option key or the spacebar, and regardless of which tool is currently selected, the grabber hand will appear. You then drag the page to display the preferred portion of the graphic and release the option key or spacebar.

The zoom tools and the grabber hand are convenience tools which expedite your ability to create a graphic by allowing you to manipulate the paint environment rather than the graphic itself. Together with the other tools and commands we have discussed, these tools provide you with the basic necessities to create any graphic, regardless of its complexity.

Many paint applications provide other tools and commands not discussed here, and some applications even lack one or two of these basics. Nonetheless, these are the features that make up the typical, established painting environment. They are the basics that you should understand in order to master the creation of free-form computer illustrations.

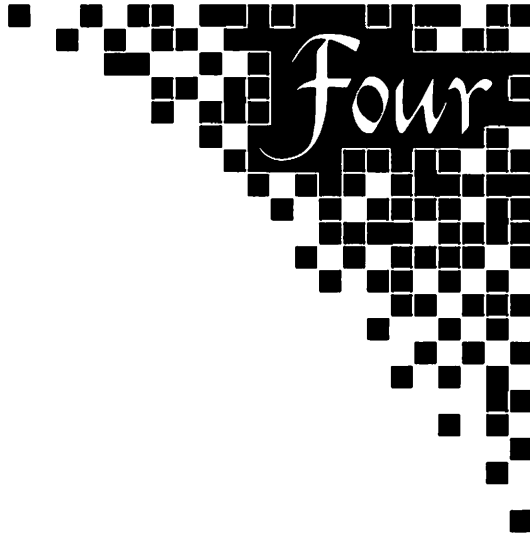

Hints, Tips, & Painting Secrets

In the previous chapter, we discussed how to operate the basic tools and commands available in most paint applications. However, while this knowledge is fundamental to successfully creating a computer illustration, few of us think in terms of tools or commands. Instead, we think about results. The question is not, *What kind of drawing will I create if I do this and this and this?* but *What must I do to satisfactorily complete this drawing?*

This chapter also deals with results. Rather than outlining the specific uses of individual tools and commands, each of the following examples demonstrates how to combine multiple tools and commands to achieve a discrete goal. Such a goal might be the solution to a common problem that you have encountered quite often. Or it might simply be a special effect that you have not previously considered. All examples are designed to span all

*The examples
in this chapter
demonstrate how
to combine tools
and commands
to achieve a
discrete goal.*

graphic types and to work with even the most rudimentary painting application.

Each goal is introduced in detail, explaining why it is important and how it fits into the larger concept of a finished illustration. This introduction is then followed by one or more solutions, accompanied by visual demonstrations. Together, these goals, solutions, and figures form a structure of tips and painting secrets that will increase your graphic proficiency as they improve the quality of your finished pieces.

Thickening a line

Paint applications give you a great deal of freedom by allowing you to create both straight and free-form lines. However, one of the drawbacks to a painted line is that after it is created, its weight is fixed. You cannot apply a new weight to an existing line, so if you want to change the thickness of a line, you must typically redraw it. This can be very frustrating, since you will often encounter times when you have the form of a line down exactly, but you would like to thicken it.

After a line is created in a paint application, its weight is typically fixed; nevertheless there are two ways to make an existing line thicker.

If you want to make an existing line thinner, you must redraw it. However, there are two ways to make an existing line thicker. The first method makes use of the cloning operation, discussed in the last chapter. The second, more dramatic method uses the “Trace edges” command.

The lasso-and-clone method

To increase the weight of a line by small increments, first select it using the lasso tool. Then press the option key and drag the line exactly one screen pixel upward. This creates a clone of the selected line offset one pixel up from the original, thus thickening the line vertically. To complete this effect, we must likewise thicken the line one pixel horizontally. To do this, you must relasso both the cloned line and its original in order to select the entire

vertically-thickened line. Then press the option key and drag the line exactly one screen pixel to the right. The line is now universally thicker.

If you want to further increase the line weight, simply relasso the line and start again. There are basically only two important rules to remember when using the lasso-and-clone method: always relasso your entire line between cloning operations, and drag only one pixel vertically or horizontally at a time.

The lasso-and-clone method is useful when you want to only slightly increase the thickness of a line.

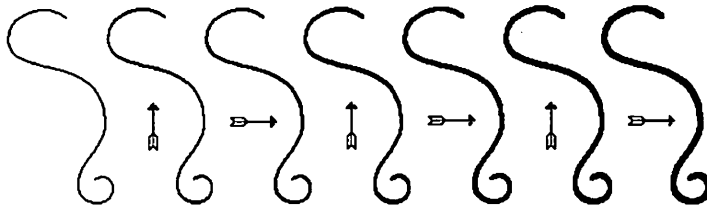

By lassoing and cloning a line, you can increase its weight by one pixel at a time. Above, we have cloned the line several times in a row, relassoing between each operation. The arrows show the directions of our drags.

The lasso-and-clone method is most useful when you want to increase the thickness of a line only marginally, by one or two pixels. If you want to thicken a line more dramatically, use the more efficient “Trace edges” command.

The trace-edges-and-fill method

The second method for thickening a line increases a line weight two pixels at a time. Additionally, it does not involve the precise movements required by the previous method.

Select the line with the marquee tool. Then choose the “Trace edges” command. This creates an outlined version of the line. Select the paint can tool and fill the outline with black or the same color as the original line. That’s all there is to it! The line is now two pixels thicker.

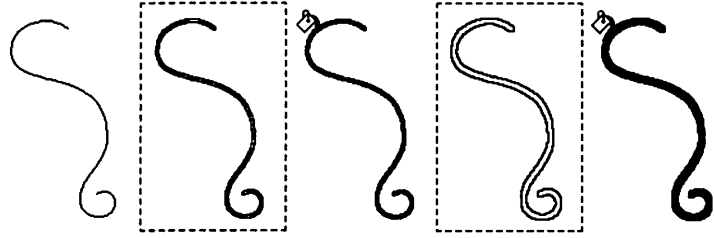

Tracing the edges of a line and filling it increases its weight dramatically. Above, we have applied this method twice in a row.

The trace-edges-and-fill method is useful when you want to increase a line weight significantly and quickly.

The trace-edges-and-fill method is a fairly general procedure that does not offer very much control. However, it is very useful when you want to increase a line weight significantly and quickly.

To thicken an existing line without redrawing it, you may use either the precise lasso-and-clone method or the speedy trace-edges-and-fill method. Both methods allow you to increase the weight of a line without starting from scratch.

Adding a custom interior to a shape

Our next tip describes how to easily fill a shape with a complex, irregular interior. As we know from the *Line and shape tools and patterns* section of Chapter 3, you may easily fill a shape with any gray value or pattern. Unfortunately, all patterns repeat at regular intervals to create a sort of patchwork quilt across a shape's interior. Such a fill, by itself, can be flat and unrealistic. Therefore, it is often desirable to spruce up the interior, making it more visually interesting by giving it a textured appearance. This involves drawing and erasing portions of the shape, while trying to avoid destroying the shape's outline.

No paint application, no matter how advanced, can help you paint inside the lines. However, there is a way to create a shape and its custom interior separately, combining them only after each is completed to your satisfaction. This way, you can make your interior as wild or as detailed as you want without harming the shape's basic form.

We call this tip the cookie-cutter method, because it involves clipping away a custom interior to match the outline of a shape.

The cookie-cutter method

First draw the shape that you want to fill. You may use any drawing tool, but the interior of the shape must be fully enclosed (no breaks in the outline of the shape). We recommend that you keep your shape simple when using this method; complicated forms and complicated interiors do not generally work well together. Next, select the shape with the lasso tool and create a clone by pressing the option key and dragging the shape to an empty portion of your screen. The clone will be used as a guide for the boundaries of your complex interior; the original will serve later as the cookie cutter.

Create your custom interior using the outline of the cloned shape as a guide. Feel free to paint outside the lines as much as you want, since any sloppiness can easily be cleaned up later.

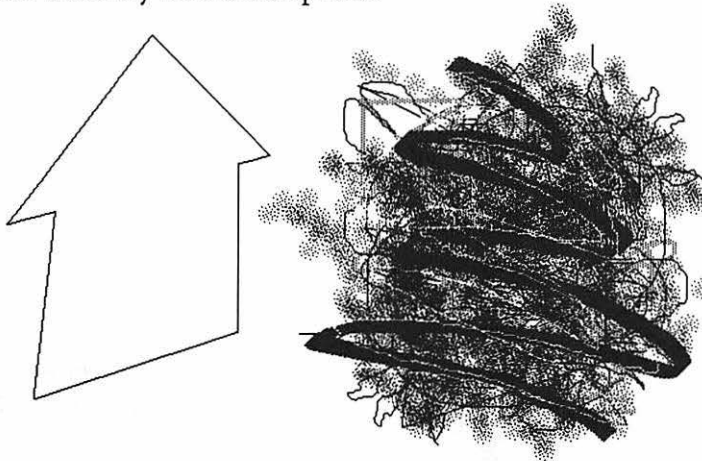

First we created the shape on the left to represent the side of a house. We then cloned the house shape and filled the clone (right) with a frenzy of uninhibited

The cookie-cutter method allows you to create a shape and its custom interior separately.

brush strokes. Notice that we have made no attempt to keep our brush strokes within the outline of the shape; in fact, you can just barely see the outline of the house. All excess paint will be clipped away in the next step.

Now that you have created your shape and its custom fill as two separate elements, it is time to create your cookie cutter using the original, unpainted shape. The idea behind the cookie cutter is to cover up the excess paint around the cloned shape while leaving its custom interior visible. Therefore, when creating the cookie cutter itself, we want to enclose the area outside the original shape, while opening up the area inside it.

Using the rectangle tool, draw a rectangle that completely encompasses the original unpainted shape. This encloses the area around the shape. Then select the line tool and draw two parallel lines very close together, each of which intersect the rectangle around the shape and the nearest edge of shape itself. Using the pencil tool, erase the tiny portions of the rectangle and the edge of the shape that are between the two parallel lines. These hollowed out parallel lines open up the inside shape while keeping the area around the shape enclosed, as shown below.

Drawing a rectangle around the cookie cutter shape encloses the area around the shape.

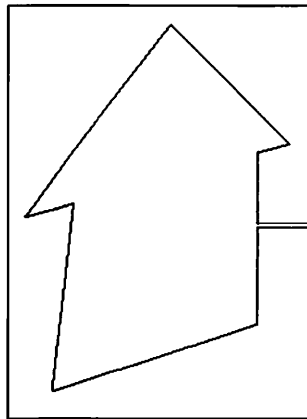

To create our cookie cutter, we began by drawing a rectangle around the shape. Then we created two horizontal lines joining the right edge of the rectangle to the right edge of the house. To open up the inside of our cookie cutter, we hollowed out the area between the two parallel lines.

After the cookie cutter is complete, lasso the rectangle and drag it in front of the cloned shape, until the cloned shape and the shape inside the cookie cutter line up as closely as possible.

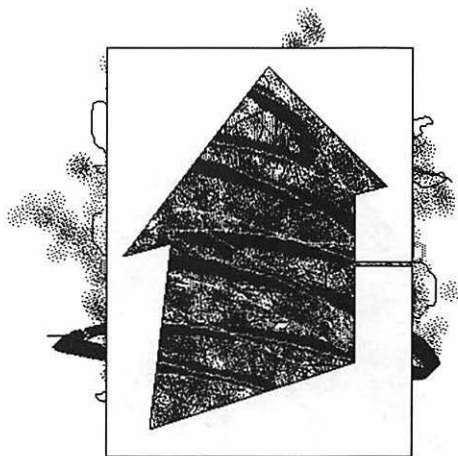

The cookie cutter conceals most of the excess paint outside the filled shape.

Here we have dragged our cookie cutter in front of our custom fill, concealing much of the excess paint outside the house shape.

The last step is to erase the rectangle, parallel lines, and any excess paint that still remains visible outside of the rectangle. This can be performed with the eraser tool, since no detailed erasing is required; all excess material is well away from the outline of the shape.



Now that we have erased the excess material around our house shape, it appears just as we anticipated. The outline is crisp and complete; the interior is dramatic and interesting.

Shapes with textured interiors can be combined with other shapes with custom fills as well as shapes with standard or transparent fills to produce a finished illustration.

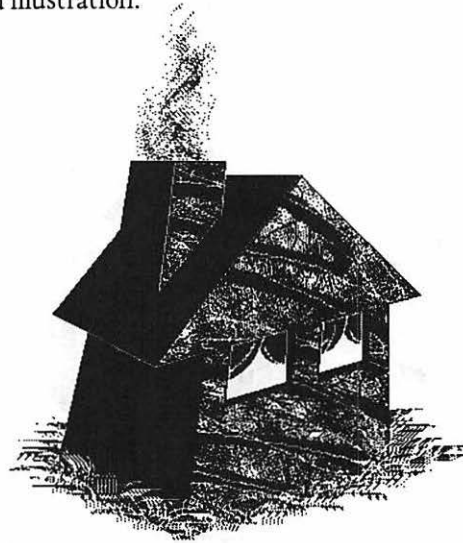

If you own a color paint application, you can fill shapes with multiple colors using the cookie-cutter method.

Here we have combined our custom fill shape with several other shapes and lines to produce a finished house. Notice that many of the other shapes in the drawing contain standard fills. The chimney contains the same textural fill we created for our first house shape, as if caught by the same angle of light.

The possibilities for the kinds of custom fills you can create are endless. You may want to experiment with multiple gray values and patterns. And if you own a color paint application, you may also try filling shapes with multiple colors using this method. No matter how wild or detailed your custom fill is, the cookie-cutter method makes it quick and easy to insert it into a shape, producing dazzlingly sophisticated results.

Throughout this chapter, we will combine the cookie-cutter method with other tips to produce additional painting alternatives. Our next section demonstrates a very similar clipping method being used to enhance the appearance of type. After that, we'll see how it can be used with gradation effects. Whenever you want to create a fill that's more than a simple gray value or pattern, you may use the cookie-cutter method.

Type effects

Our next few tips explore different ways of manipulating type in a paint application. As we discussed in the previous chapter, type is no different from any other graphic element. It can be altered or enhanced using any painting tool. In fact, the prime advantage of type created in a paint application is that it can and should be manipulated graphically.

Big type sizes typically require manipulation more often than smaller sizes. This is because typeface vendors rarely provide screen font sizes that are larger than 24-point. Whenever you create type in a point size greater than the largest screen font available in your System for that typeface, your paint software has to scale the largest screen font accordingly. Therefore, if the largest screen font for a specific typeface is 24-point, and you create a line of 72-point type in that font, you are asking your software to scale its definition of the font by $72 \div 24$, or 300%. As a result, the type will also be 300% as jagged.

Type created in a paint application can and should be manipulated graphically.

72-pt. Souvenir
72-pt. Souvenir

Shown above are two lines of 72-point type set in the typeface ITC Souvenir. In the first example, we used the version of the typeface developed by Adobe Systems Inc. Adobe, like most vendors, does not provide screen font sizes larger than 24-point. Therefore, our paint application was forced to scale the font by 300% in order to meet our size specifications, creating a very jagged effect. In the second example, we used the version of Souvenir sold by Bitstream Inc. Bitstream distributes a 72-point screen font, so no scaling is required, resulting in a smoother appearance.

In a paint application, incongruities in letter spacing can be easily remedied.

The problem with very large screen font sizes, besides their rarity, is that they consume a great deal of space on your System disk or hard drive, sometimes over 100 kilobytes for a single alphabet. And no matter how large your screen fonts are, it is always possible to create type that is twice as large. So large point sizes and jagged appearances tend to go hand-in-hand with type in a paint application.

The best way to improve the appearance of large, jagged type is to smooth it out by hand using the pencil tool. However, this can be an extremely difficult and time-consuming task even for an experienced artist. Here are some tips that can be used to easily and dramatically improve the appearance of large type, without requiring hand-drawing.

Changing letter spacing

Our first method for improving the appearance of large type involves altering its letter spacing, which is the amount of horizontal space between individual letters. When small screen font sizes are enlarged to meet the requirements of large type, the amount of space between letters is enlarged proportionally. Incongruities in letter spacing therefore become more obvious as type gets larger. These incongruities can be eliminated easily using the lasso tool, with surprisingly effective results. For example, if the space between a pair of letters looks too large (letter spacing is rarely too small), lasso the right letter in the pair plus all letters to the right of it in the same line, and drag them left until the spacing is more consistent.

Type

This is how the word "Type" looks when typed from the keyboard at a large point size in Times Bold. Notice that there are large spaces between the "T" and the "y" and between the "y" and the "p" that are inconsistent with the smaller, more attractive spacing between the "p" and the "e." In a paint application, this can be easily remedied.

Type

Here, we have reduced the large letter spacing that plagued our word a moment earlier by selecting the individual letters with the lasso tool and moving them in relation to each other. Notice that we have dramatically lessened the space between the “T” and the “y” so that the “y” fits snugly beneath the overhang of the larger letter. The space between the “y” and the “p” has also been reduced to the point that the two letters touch. The space between the “p” and the “e” remains the same. The result is that the spacing between all letters appears consistent, thereby improving the appearance of the word as a whole.

Manually altering the letter spacing in a word or line of text improves the visual quality of large type quickly and easily. However, it is generally only a first step. After all, letter spacing has no effect on large type’s typically jagged appearance. The next two tips explain methods designed specifically to lessen this problem.

Filling text with a pattern

The easiest way to make large type look less jagged is to fill it with a gray value or pattern. Because patterns are not 100% black, but are instead composed of interacting lights and darks, they “open up” the form of a letter, loosening the structure of the outline and making jagged edges seem more homogeneous.

There is really no trick to filling type with a pattern. You simply select the type with the lasso tool, select an appropriate pattern, and choose the “Fill” command, as described in the *Lasso and marquee tools, basic commands* section of Chapter 3. The only thing to watch for is characters such as “O”s and “B”s that have enclosed centers. These areas will fill in along with the black portions of the character, destroying the appearance of the letter. To avoid this, open up the enclosed areas by erasing breaks into the characters using the pencil tool prior to choosing the “Fill” command.

The easiest way to make large type look less jagged is to fill it with a gray value or pattern.

Large Type

We begin with some large, jagged Times Bold type, for which the letter spacing has already been adjusted. Notice that the letters “a,” “g,” “e,” and “p” have enclosed centers. Breaks must be erased into these enclosed areas to prevent them from filling in.



All enclosed areas have now been opened up by using the pencil tool to erase small breaks into their respective letters. Then we select the type with the lasso tool.



Finally, we select a simple horizontal line fill pattern, and choose the “Fill” command for the selected text. Since this pattern is consistent with the jagged edges in our type, the type appears smoother while still retaining its legibility.

A pattern loosens up a text block’s jagged edges quickly and easily without diminishing its legibility.

Filling type with a pattern loosens up the jagged edges quickly and easily without diminishing the legibility of the text. The problem with patterned type is that it is not terribly exciting. Like any other graphic element filled with a pattern, it appears flat and uninteresting. To give large type a little more pizzazz, try customizing its interior. This method combines the “Invert” command with the cookie-cutter method discussed earlier in this chapter.

Adding a custom interior to type

Earlier in this chapter, we showed you how to fill a simple shape with a customized pattern using the cookie-cutter method. Using a similar method, we can do the same thing for type. A custom fill gives type a textured, or “antique” appearance while disguising the jagged edges associated with large type. Type with a custom fill appears smoother and more interesting than plain black type.

The cookie-cutter method essentially clips away unwanted portions of a custom fill to produce a filled shape. However, a line of type is much more complex than a simple shape, since each letter is a shape unto itself. Rather than making type into a cookie-cutter, we make it into a mold into which the custom fill is poured.

Select the type that you want to fill using the marquee tool, leaving a quarter-inch margin inside the marquee. Then select the “Invert” command. The letters change to white and the area around the letters inside the marquee changes to black. This black area encloses a boundary around the letters in much the same way that the rectangle did in the cookie-cutter method.

The white letters are presently fully enclosed by the black area. In order for a custom fill to get into these letters, they must be opened up by erasing a break into the black area for each letter. We recommend that you use the line tool to draw a 2-point vertical white line from the upper edge of the black area into the top of each letter, as shown in the figure below.



By inverting large type and erasing breaks into the top of each letter, we create a mold into which a custom fill can be poured.

A custom fill gives type a textured appearance, while disguising the jagged edges associated with large type.

Create your custom fill on an empty portion of your page, separately from your type. Eventually, this fill will be inverted. Since type generally looks best when filled with a dark pattern, we recommend that you create a fairly light custom fill now, like the one shown below.

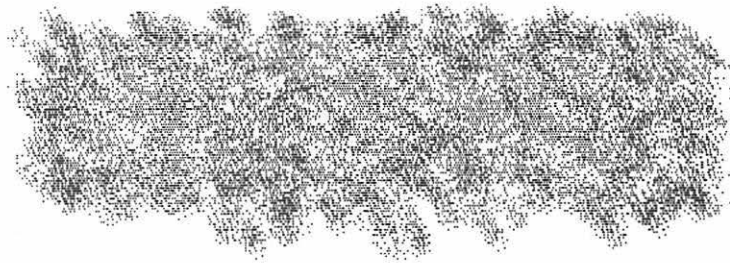

This custom fill was created with the spraypaint tool and a simple horizontal line pattern. That we have created a light fill means that when we reinvert the type, it will appear to be filled with a dark pattern.

After your custom fill is complete, select the inverted type with the lasso tool and drag it in front of the fill. If all of your breaks are created correctly, you should be able to see your custom fill inside each letter. Next, select both fill and type with the marquee tool, and again choose the “Invert” command. This converts your text to dark type on a white background.

The “Invert” command converts cookie cutter text to dark type on a white background.



After positioning our inverted type in front of our custom fill, we marquee the whole thing and choose the “Invert” command. Our type now appears filled with a dark custom pattern inside a white rectangle.

The last step is to erase the excess custom fill and break lines.

Large Type

Using the eraser tool, we delete the vertical lines going into the top of the letters as well as the excess custom fill outside of the white rectangle. The finished product is a textured, interesting line of text, which appears less jagged than before.

As you can see above, type filled with a custom interior has a unique, textured appearance viewers do not usually associate with computer-produced type. This method is then doubly useful, since it not only smooths the jagged edges of large characters, but also conveys a certain graphic personality. Type combined with a custom fill is both friendly and professional.

You can create impressive type effects in a paint application that are not possible using other kinds of graphics software.

Type created in a paint program does not have to be ugly. Although the results of your experimentation will depend upon the screen font sizes loaded into your System file, large type can actually be quite effective. In fact, you can create impressive type effects in a paint application that are not possible to produce using other kinds of graphics software.

Any time you are using large type, whether it appears jagged or not, you should adjust the letter spacing using the lasso tool. This will give your text a clean, professional appearance. If your type also looks jagged, try filling it with a gray value or pattern. This will disguise its jagged appearance without destroying its legibility or requiring you to expend much time and energy. If patterned text looks too flat, invert the type and combine it with a custom fill. This final method is slightly more time-consuming than its predecessors, but the results are well worth it.

Creating and using gradations

A gradation can be used to add an appearance of depth to a simple element, often heightening its realism.

Our fourth set of tips addresses how to create consistent shading effects using gradations. Gradations are transitional fill patterns in which one gray value progresses into a lighter or darker gray value through a series of incremental steps.

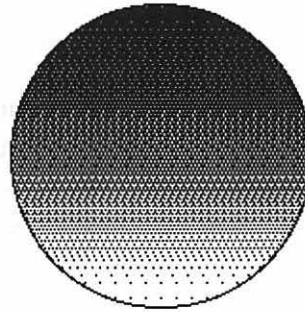

The interior of this circle is filled with a typical gradation, fading from a dark gray value at the top to a very light gray value at the bottom in consistent, incremental steps.

A gradation can be used to fill a simple graphic element, giving it the appearance of depth and often heightening its realism. A gradation can also function as a custom fill, serving as an alternative to a standard flat pattern or smoothing out the jagged edges of large type. You may also intermix various incremental gray values, creating realistic shading techniques, which would be impossible to imitate using non-paint type computer applications.

The next few tips will prove specifically useful to those of you who own monochrome painting applications, which offer a limited range of features. Most color programs offer automatic gradation commands, allowing you to blend one color into another through a rainbow of user-defined increments. Some high-end monochrome applications provide gradation options as well. However, for the rest of us, gradations require a little more effort. They must be created by hand and clipped into a shape using the cookie-cutter method. Fortunately, the results justify the effort; a mastery of incremental gray values improves any artist's drawing potential.

The following are methods for creating and using custom gradations.

The spraypaint-layering method

There are two basic methods for creating custom gradations. The first of these, the spraypaint-layering method, is the quickest and easiest of the two, though it is also the least predictable. Because this method uses the spraypaint tool, which varies greatly from application to application, the results can be erratic, and it may take some practicing before you are fully satisfied with your results. At the same time, gradations created by this method are very individualized; no two are alike. The spontaneity involved in their creation can add sparkle to their final appearance.

The idea behind the spraypaint-layering method is to perfect a single gradation swash that is later cloned repeatedly to form a large-scale gradation. This swash must be exactly straight, and it should fade evenly from dark to light. To this end, we must use the spraypaint tool in a very controlled manner. First, press the shift key while drawing with the spraypaint tool to constrain your swash to a vertical or horizontally line. Second, because it is exceedingly difficult, if not impossible, to create a graded swash with one sweep of the spraypaint tool, you must create your swash as a series of multiple sweeps, one in front of another, in front of another, and so on.

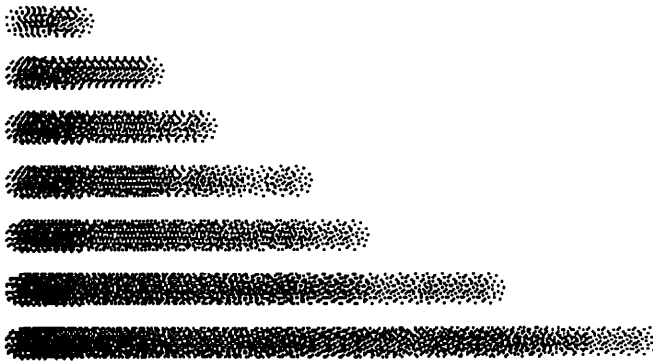

The first step in the spraypaint-layering method is to perfect a single gradation swash.

For our example, we will create a gradation that fades from left to right. This means that our swash must be oriented horizontally. If we were creating a vertical gradation, the swash would be vertical as well. In the first example above, we press the shift key and draw a very short line with the spraypaint tool. In the next example—still pressing the shift key—we position our

spraypaint cursor at the same spot we began our previous drag, and draw a slightly longer line directly over the first. We then draw a slightly longer line over that, and another slightly longer line over that, and so on, until we have layered seven progressively longer spraypaint lines in front of each other to create the last example.

The principle behind layering line after line of spraypaint is simple: the area of the swash that has been painted over the most is the darkest, while the area that has been painted the least is the lightest. As long as each line of paint begins at the same point and ends slightly farther along than its predecessor, the effect will be that of an evenly-graduated swash.

The next step is to clone this single swash into a larger graduated mass. Using the lasso tool, select the swash. Then press the option key and drag a clone of the swash to a perpendicular location, flush with its original. Repeat this action until your gradation is the desired size.



Here we have selected the swash and are preparing to drag a clone of it downward, perpendicularly to its horizontal orientation.

The area of the swash that has been painted over the most is the darkest; the area that has been painted the least is the lightest.

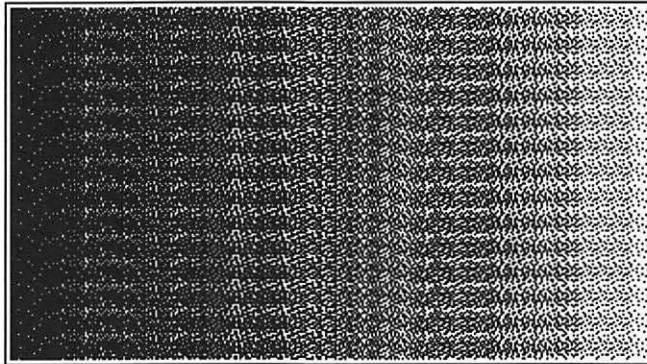

By repeatedly option-dragging downward, we create a column of 14 end-on-end swashes to create this finished gradation.

After your gradation is the appropriate size, it can be clipped into a shape using the cookie-cutter method just like any other custom fill.

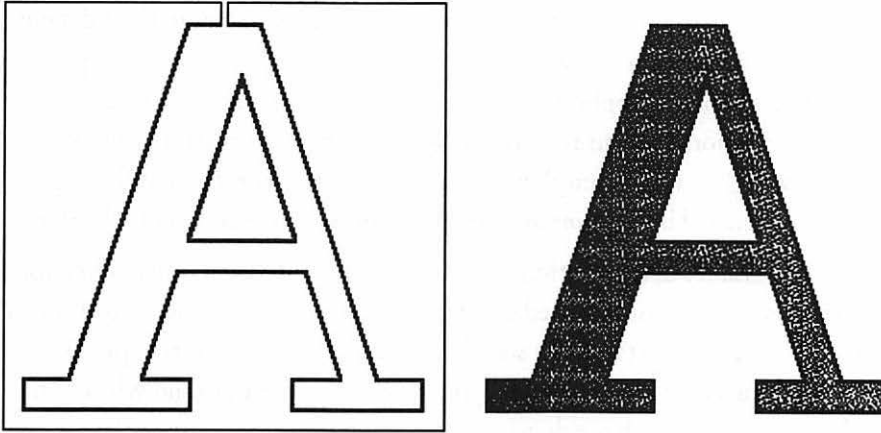

On the left, we have created a cookie cutter outline of a large letter “A.” Positioning the cookie cutter in front of a portion of our gradation and erasing the excess paint produces the image on the right.

Once mastered, the spraypaint-layering method is ideal for creating quick gradations with a unique appearance. You may also notice that objects filled with spraypainted gradations have a hearty, textural appearance, adding weight and ruggedness to your drawings. If you aren't satisfied with this appearance, however, or you desire a smoother transition between light and dark, you may spend some extra time and try the following method.

The custom-gray-value method

The second tip for creating a fluid gradation concerns the custom-gray-value method. This method involves more work, but it is also more reliable and more versatile than the spraypaint-layering method. You should use this method if you plan to employ gradations frequently throughout your artwork.

You should use the custom-gray-value method if you plan to employ gradations frequently throughout your artwork.

Gradients, as we have discussed, are made up of a consistent series of incremental gray values. Therefore, the first step in creating a gradient is to establish these gray values.

All paint applications include a selection of gray values in their default pattern library. Some selections are very limited, others are more complete. However, almost no application includes enough gray values to create a quality gradient. For this reason, it is generally best to create a series of customized gray values, employing the methods for pattern modification that we discussed in the *Line and shape tools and patterns* section of Chapter 3.

Gray values in a gradient must flow evenly into each other. Therefore, every gray value must be based upon its neighbors. The best way to ensure a consistent flow is to start with solid black, then delete one or two pixels from each successive pattern until you eventually arrive at solid white. This is the manner in which we developed the following 24 incremental gray values.

Since one gray value in a gradient must flow evenly into its neighbor, the two must be based on one another.

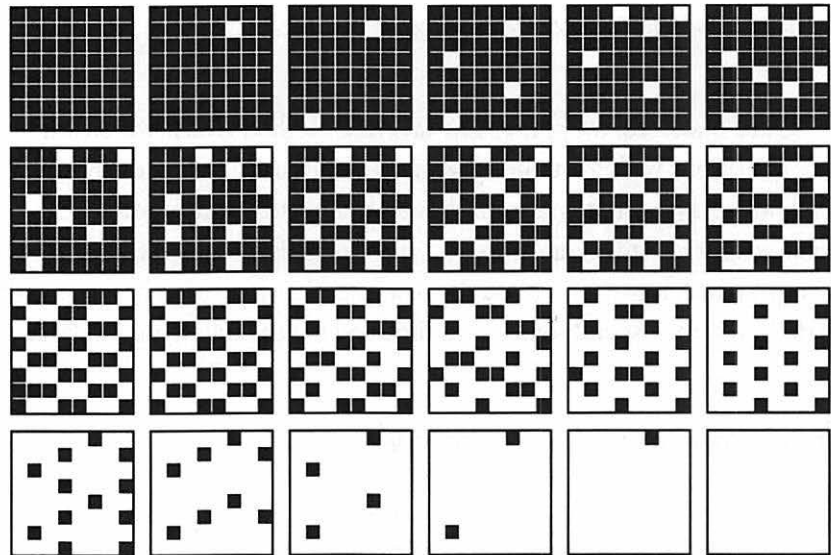

The simplest way to create a series of evenly flowing gray values is to duplicate those shown above. Each gray value is magnified, mimicking your application's display when you double-click on a pattern. Thus, every black square represents one screen pixel.

After you have finished creating the 24 gray values shown above, you may use them to draw your gradation. In the gradation that we create, all incremental gray values will be given the same emphasis. This is not the only kind of gradation you may produce, but it is the easiest.

The first step is to construct a grid of bars. Each bar represents the size of a single gray value. To ensure equal emphasis, each bar should be the same size. This is done by drawing one bar with the rectangle tool and then cloning it several times to create the other bars in the grid.

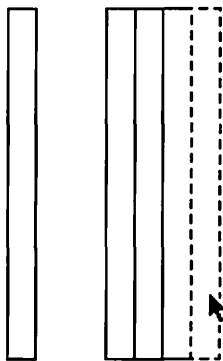

To draw a gradation using gray values, you must first construct a grid of bars.

Again, we will be creating a gradation that fades from left to right. This means that the bars in our grid must be very tall and very thin, as shown above. If we were constructing a vertically flowing gradation, the grid bars would be very wide and very short. Grid bars are always oriented perpendicularly to the flow of the gradation. After drawing our first bar with the rectangle tool, we lasso it, press the option key, and drag a clone of the bar to the right until the right edge of the original is exactly covered by the left edge of the clone. We then repeat this action until we have created a row of 24 bars, one for each of our gray values.

After you have created a bar for each gray value in your gradation, your grid is complete. You could then fill each bar with a different gray value using the paint can tool. But then each gray value would be separated from its neighbor by a black line, interrupting the visual effect of one pattern flowing into another. So instead select the dotted, or invisible, line weight

and trace each bar using the filled rectangle tool, selecting a progressively lighter (or darker) gray value each time. The invisible line weight ensures that there is no line between any two gray values.

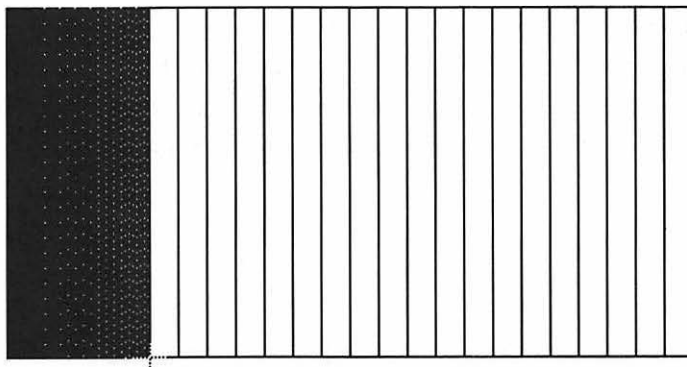

Starting with the solid black gray value, we use the filled rectangle tool with the invisible line weight to trace the first bar in our grid. We then trace each succeeding bar with the next lighter gray value.

A completed gradation can be clipped into a shape using the cookie-cutter method just like any other custom fill.

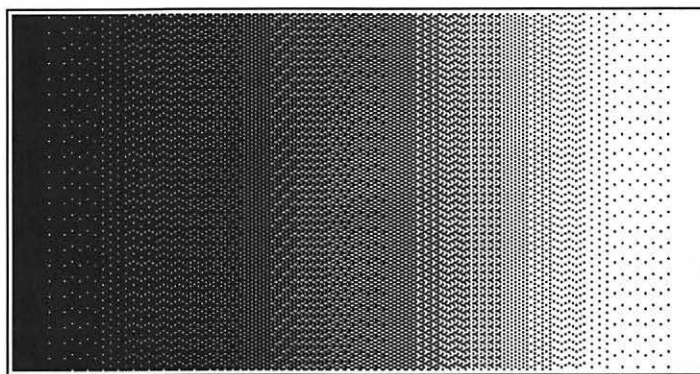

This is how a typical gradation created by the custom-gray-value method looks when completed. To better demonstrate its boundaries, we have surrounded it with a box.

After your gradation is completed, it can be clipped into a shape using the cookie-cutter method just like any other custom fill.

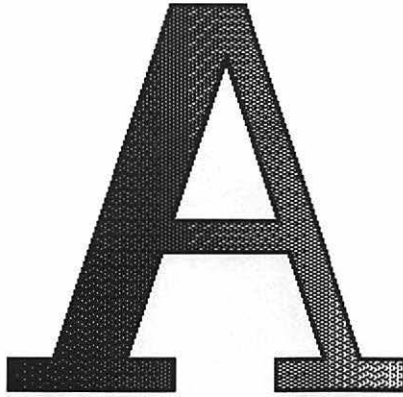

Finally, we clip our gradation with the cookie cutter created for our previous example.

As you can see, the custom-gray-value method provides much more precise, less gritty gradations than the spraypaint-layering method. The tradeoff, of course, is that it requires more time. However, there is another advantage to the custom-gray-value method that we haven't discussed—versatility. A palette of successive gray values can be used to create more than a simple gradation. In fact, such a palette is one of the most functional painting devices that exists.

Painting with custom gray values

A sizable selection of related gray values is necessary to create realistic illustrations using a monochrome paint application. This idea is less a tip than a bit of general advice. In fact, the only way to realize the full potential of similar gray values is to experiment with them yourself. Begin by using only the paintbrush tool, limiting yourself to a single brush shape and the 24 gray values that we displayed earlier. After you feel comfortable with one brush shape, try experimenting with others. The spraypaint tool can also be useful, but to a lesser extent, due to its random nature. We also recommend that you create your own palette of gray values; ours is by no means the only possibility. Remember to create them in a succession, deleting one or more pixels from a dark pattern to create a lighter one, so that the transition from gray value to gray value is consistent.

A sizable selection of related gray values is necessary to create realistic illustrations using a monochrome paint application.

No tool is as powerful as the paintbrush combined with a palette of interdependent gray values.

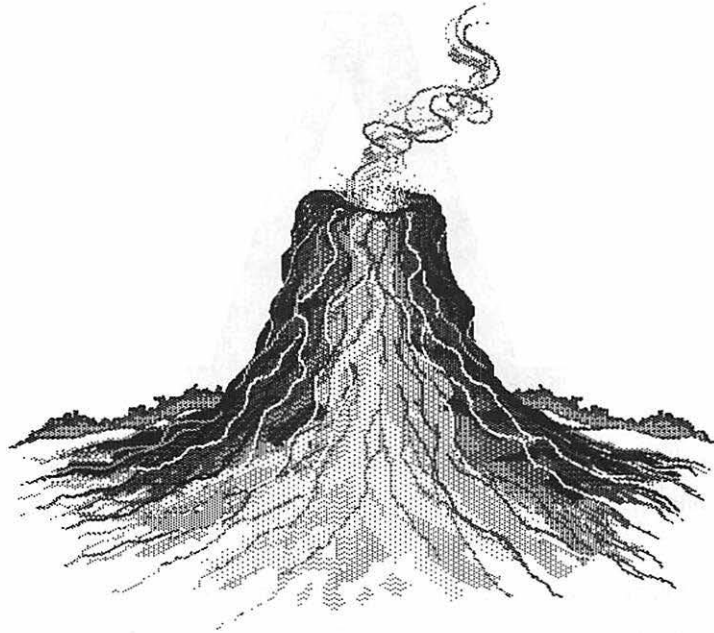

This image of a smoldering volcano was created entirely with the paintbrush tool, a handful of brush shapes, and the 24 gray values displayed earlier. Notice how fluidly one gray value mixes with another, regardless of the degree of contrast between them.

No tool is as powerful as the paintbrush combined with a successful palette of interdependent gray values. Together, these features can be used to create both polished gradations and realistically shaded, full-blown illustrations.

If your paint application doesn't provide gradation fills automatically, you may create them by hand. The spraypaint-layering method is ideal for creating quick gradations, where uniqueness rather than consistency is paramount, or where you want a textured look. If you desire a more polished appearance and are willing to expend a little extra effort, we recommend the custom-gray-value method. Both methods provide custom fills that can be saved as independent paint documents, then later clipped into shapes in a variety of illustrations.

The custom-gray-value method is also useful because creating a palette of related gray values is the first step in executing highly realistic paint illustrations. Progressively lightening or darkening patterns can be painted in a succession to produce truly amazing images. (See Chapter 7 for a step-by-step demonstration of this method.)

Our final tip is unlike others in this chapter in that it doesn't work in rudimentary applications. We throw it in simply as a bonus. This tip discusses the fill-scale-and-skew method, used to add a shadow to any image. In order to use it, your application must offer a "Slant" or "Skew" command.

Adding a shadow to an image

In real life, everything has a shadow. It doesn't matter if it's high noon, or if the sun is setting, or if you're indoors and the only light source is a small window, or if you're on a lonely road at midnight under a street lamp; there is always a shadow to be seen. You can choose to ignore it, of course, but a shadow in a drawing invariably enhances its realism. Shadows also imply an object's environment. For example, if an object and its shadow touch, then the object is touching some surface, presumably the ground, at that point. If the object and its shadow do not touch, then the object is hovering above the surface upon which the shadow is cast.

The shape of a shadow is directly dependent on the form of the object that casts it. This makes shadows very difficult to draw accurately with a pencil on paper. But using a computer, it's all that much easier, because in reality, a shadow is simply a transformed clone.

In order to create an effective shadow, your application must offer a "Slant" command.

The fill-scale-and-skew method

To create a shadow, you must first clone the object that casts it. Select the object with the lasso tool and press the option key while dragging it to an empty portion of your page. Shadows are not as detailed as the objects that cast them; in fact, they have no detail whatsoever except for their outlines. Therefore, while your clone is still selected, select the solid black

pattern and choose the “Fill” command. This will obliterate all detail inside the clone, leaving you with an exact outline of the object filled with solid black.



Though this wasp is an extremely complex image, it will be easy for us to give it an accurate shadow, increasing the realism of the overall graphic as well as hinting at the wasp’s environment.

*The “Fill”
command changes
a clone into an
exact outline of
an object with a
uniform interior.*



After cloning the wasp, transform the clone into a silhouette using the “Fill” command. We have included a vertical line to the right of the wasp indicating its height for comparison with the following figure.

The next step is optional, depending on where you want to cast your shadow, in front of or behind the object itself. A shadow is cast by an object onto the ground below it. When you are translating the three dimensions of real life onto the two dimensions of a piece of paper, the portion of the ground that is in front of an object must be represented fully below the object and the portion behind the object must rise from the object's base. This is because the ground appears to recede upward toward your visual horizon (see the *Demonstrating depth* section of Chapter 2 for more information). The practical offshoot of this is that if you plan to position a shadow in front of your object, you must reflect it by selecting the cloned image with the marquee tool and choosing the "Flip vertical" command. If you want to create a shadow behind the object, it should not be flipped.

The next two operations, scaling and skewing, must be performed, but to what degree is entirely up to you. You generally want to scale a shadow down to a smaller size than the object, indicating that the light source is above the object. If you enlarge your shadow, the light source must be very low, like a setting sun. Marquee your clone (if it is not already marqueeed from flipping it), press the command key, and drag at one of the corners of the marquee to scale your shadow to the appropriate size. Then, while the shadow is still marqueeed, choose the "Slant" or "Skew" command. This will attach a handle to each of the four corners of the marquee. Press the shift key to constrain your skew horizontally and drag one of the handles either left or right, so that the shadow slants away from the light source.

If you plan to position a shadow in front of an object, you must reflect your cloned image vertically.

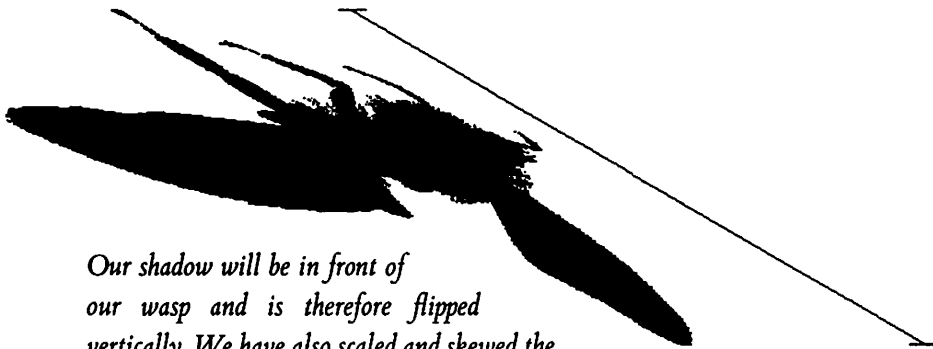

Our shadow will be in front of our wasp and is therefore flipped vertically. We have also scaled and skewed the shadow, the degrees of which are displayed by the line to the right of the wasp. Notice that the line is shorter than the vertical line in the previous figure, indicating that the shadow has been scaled down. The line is also slanted by over 45°, indicating that we have skewed the shadow dramatically rightward.

A shadow can add realism to the simplest or the most complex of objects.

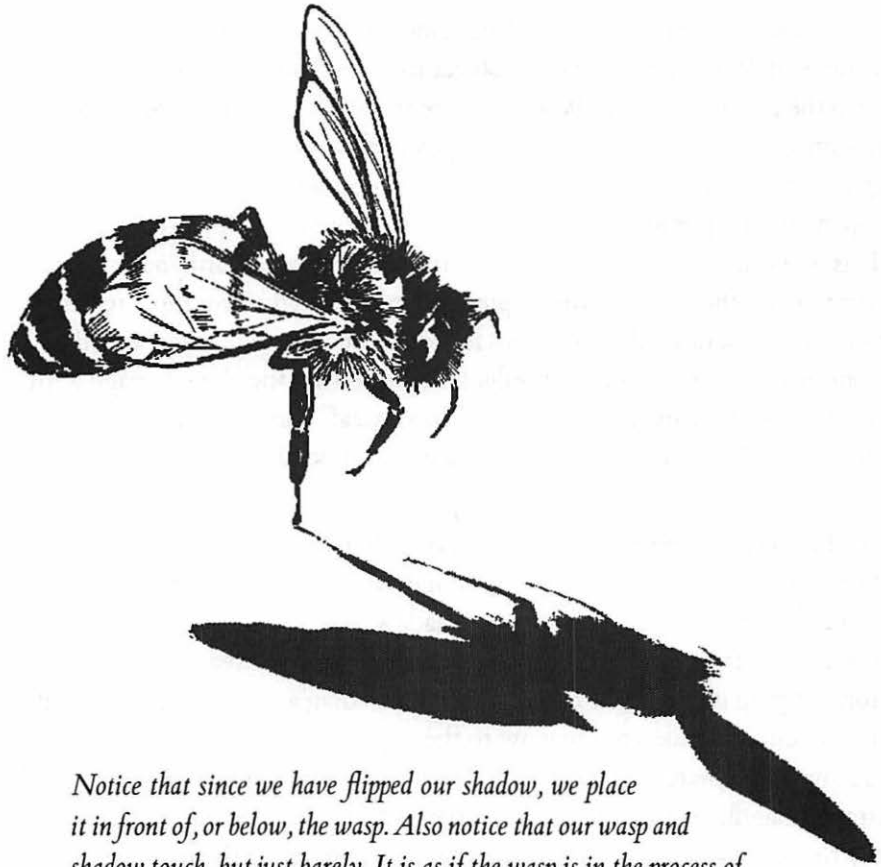

Notice that since we have flipped our shadow, we place it in front of, or below, the wasp. Also notice that our wasp and shadow touch, but just barely. It is as if the wasp is in the process of landing on some smooth surface. Finally, we have filled the shadow with a dark gray value, so that it does not compete with the wasp for our attention. This was accomplished by clicking on the shadow with the paint can tool.

After the shadow is finished, it should be coupled with the object itself. If the shadow is behind the object, the object should be lassoed and dragged in front of the shadow. And as we mentioned earlier, if the object touches the ground or some other surface, the shadow and the object should touch. If the object is hovering or in flight, its shadow should not touch.

A shadow can add realism to the simplest or the most complex of objects. Not only is it easy to create, but it serves more than one purpose. A shadow indicates the location and nature of your light source. It also tells the

audience where the ground is in relationship to the object. And, last but not least, a shadow proves that you can add sophistication to a graphic without being able to draw one whit.



The tips in this chapter have outlined methods for improving the appearance of bit-mapped type and for adding elegance to a simple drawing. Using these methods in real drawing situations will help you to both easily spruce up your finished illustrations and to save time while you're at it. And in using our methods, you will probably discover methods of your own, increasing your proficiency and speed.

In the chapters that follow, we will take you from beginning to end through some actual illustrations. You will occasionally see the concepts we have discussed in this chapter pop up in both familiar and startlingly different situations. It is to be hoped that this background will make future projects easier and increase your learning potential.

Part 2

Drawing from Scratch



Basic Hands-On Projects

Now that we have discussed the fundamental techniques, tools, and commands useful in creating any paint graphic, it is time to work through a series of sample projects. In this chapter and the two that follow, we discuss each of the features and methods that we have introduced so far by actually putting them to use. Each project is “hands-on”—demonstrating how to create free-form computer graphics by requiring you to create the graphics yourself, according to our easy-to-follow, concise guidelines.

In this chapter, we will create two very basic graphics: a page ornament and a simple cartoon. Each project concentrates on the most elementary aspects of graphic composition. You will not only learn how to think through a drawing, but also how to execute it using a typical paint application. If at any point you are unsure of a command or tool that we ask you to access, refer to Chapter 3 for a complete discussion.

As you work through each project, don't worry if your graphics do not exactly match ours dot-for-dot. In fact, it is preferable for you to work your own style into each project. By following our directions in a manner that seems comfortable to you, you may develop personal drawing habits that help you when creating artwork in the future.

Creating a page ornament

Our first project is to create a page ornament, which is a simplified representation of an everyday object, designed to impart basic information in an immediate and friendly manner. The page ornament we create will be an ordinary house with a tree and a fence.

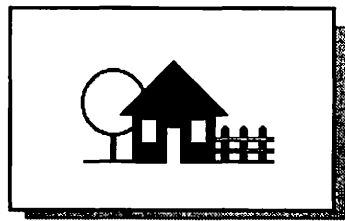

Our first sample project is to create this easily recognizable icon of a house.

With their immediacy and simplicity, page ornaments can satisfy a number of graphic requirements. Generally, a page ornament is used:

1. To quickly spruce up a dull page.
2. To act as a visual signpost for your reader, highlighting pertinent text.
3. To combine with other page ornaments to form a more complex graphic.

For example, suppose that you need to create a newsletter in a short period of time. You want to be able to throw it together, but you don't want

to turn your readers off with a dull appearance. It doesn't have to be fancy, but it should be visually interesting enough to attract readers and highlight important articles. Page ornaments are perfect for this situation, since they are quick and easy to create. They are also generic enough to be used over and over again, from one newsletter to another, or even multiple times in the same newsletter.



Above are more examples of page ornaments. Each graphic is intuitive; no text is required to explain its purpose or what it represents. Instead, it is the ornament that clarifies and highlights text.

The tool that we will be using to create most of our page ornament is the line tool. The line tool is extremely versatile for creating geometric objects. We will be using this tool first to sketch our shape, and later to add finishing touches.

A common mistake when beginning a graphic is to jump right in and start drawing, without establishing some guidelines. For example, we could start drawing at the bottom corner of the tree, then draw the house, then draw its roof, then draw the fence, and so on. This kind of haphazard technique can work, but it generally isn't the best approach. What if after you draw the tree, you discover it's too small in relation to the house? Then you have to erase the tree and start over. If you are sufficiently organized in the first place, you can work through a drawing with only minimal amounts of erasing and redrawing.

It is often best to begin by sketching the form of the central object, and then work outward. With this in mind, we will create a simple cross to represent the center of the basic form of the house. We will then use this cross as a reference to create the outline of the house.

Select the line tool from your application toolbox. Then press the shift key and draw a horizontal line the length shown in the following figure. Incidentally, by pressing the shift key, you constrain your line to be either horizontal, vertical, or diagonal.

We will create one more shape with the rectangle tool, representing the door to the house. Once again, we will be drawing from center. If your application has a “Draw from center” command, it will still be active. If not, press the option key while drawing.

Notice that the squarish body of the house is cut into four quarters by the cross. Draw from about the middle of the lower vertical line of the cross, down and to the right, until the bottom of the door is flush with the bottom of the house, and the width matches that shown in the next figure.

Next, select the line tool again. We will use this tool to create the roof of the house. While pressing the shift key, draw two diagonal lines that intersect near the top of the vertical line of the cross, representing the sloping roof of the house. The horizontal line of the cross acts as the bottom of the roof.

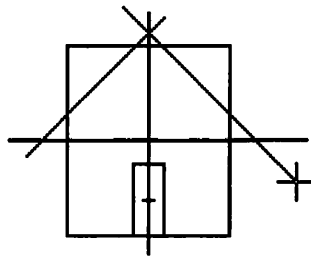

This is our house as it appears with doorway and roof. A small horizontal line has been added to mark the center of the doorway. Notice how our diagonal roof lines appear to be rather sloppy, since they extend past the cross lines. These are sketch lines, and any ragged edges will be erased in the next step.

Now, select the eraser tool. Use this tool to delete any ragged lines that extend past the main form of the house.

In a moment, we will fill the house with solid black, using the paint can tool. However, first we must erase the center of the cross inside the house, carefully avoiding the door, so that the paint will seep into all four corners of the house. Don't worry about the small enclosed nooks at the top and the two sides of the roof. These will have to be filled separately.

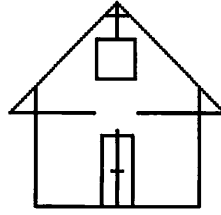

This is the house as it appears after cleaning up ragged edges with the eraser tool. We have also erased the center of the cross to allow more efficient filling.

Select the paint can tool from the application toolbox. We will use this tool to fill the interior of the house. Also, make sure that the solid black pattern is selected.

First click with the paint tool in each of the small triangular nooks in the ceiling. As you click, each nook will become filled with black.

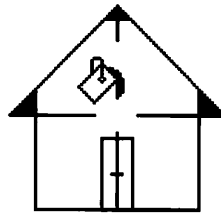

Clicking with the paint can tool in the small nooks in the ceiling fills them with solid black. Our paint can tool is now poised to fill the main portion of the house.

After the nooks are filled, click with the paint can inside the main portion of the house. Now, the entire house, except for the door, should be solid black.



This is the solid black house after being completely filled using the paint can.

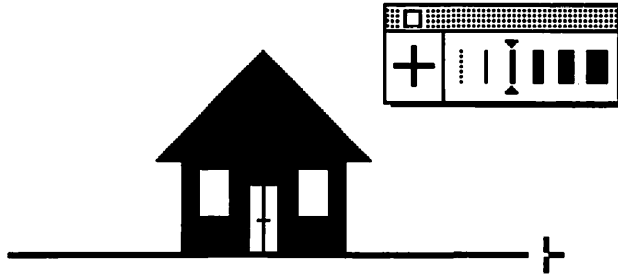

Create the ground level line by pressing the shift key and drawing horizontally with the line tool. The line weight window in the upper right corner displays our current selection.

Now we want to get rid of the lines inside the door and open up the ground line under the door. To do this, we will draw the door in the same way we drew the windows. Select the filled rectangle tool again, and select the invisible line weight. Then trace the outline of the door from corner to corner.

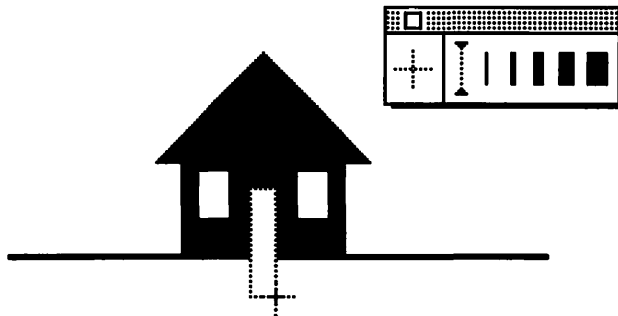

Redraw the door with the filled rectangle tool. The line weight window displays our current selection. Since we haven't changed our pattern selection, the rectangle is filled with white.

This finishes the house. All that remains is to create the tree and the fence, elements which define the yard. The tree, you may recall, is even more simplified than the house, being no more than a fat line with a circle on top. We will create this circle first.

Select the ellipse tool. Then change the line weight to 2-point, the second thinnest line, which we used to draw the ground level. Starting about

even with the top of the roof and an inch to its left, press the shift key and drag down and to the right to draw a circle as shown in the figure below. (The shift key constrains the ellipse tool to create a perfect circle.)

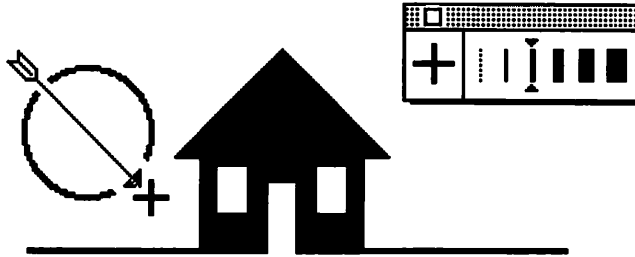

Create the top of the tree by pressing the shift key and drawing with the ellipse tool. The arrow shows the direction of our drag, while the line weight window displays our current selection.

To create the trunk of the tree, select the line tool and change the line weight to the next thicker choice. (If your line weight menu offers more choices than the one shown in our figures, select the line weight that is twice as thick as the previous selection, or 4-point.) Then press the shift key and draw with the line tool down from the middle of the base of the circle to the ground line.

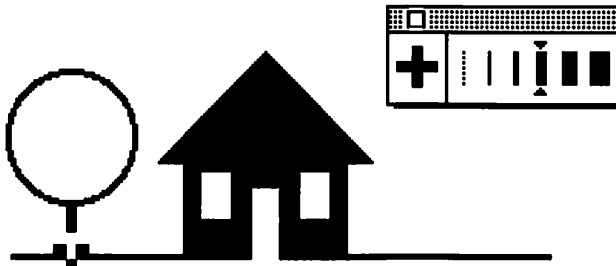

Create the trunk by pressing the shift key and drawing down from the circle of the tree to the ground level. The line weight window displays our current selection.

Our tree was very easy to create. The fence involves only slightly more work. To create the fence, we will be using a separate vertical and horizontal

line weight component. If your paint application does not provide different weight components, you will have to alternate between the two line weights as you draw the vertical and horizontal lines of the fence.

Select the second to fattest line weight, or 6-point, as the vertical component and the thinnest weight, or 1-point, as the horizontal component. This is accomplished in a variety of ways, depending on your specific application. Typically, if your line weight menu is oriented horizontally (as shown in our figures), click above the weight option to select a vertical component and below the weight option to select a horizontal component. If your menu is oriented vertically, click to the left of the weight option to select a horizontal component and to its right to select a vertical component.

After selecting the correct line weight components, press the shift key and draw three vertical lines using the line tool, as shown in the next figure. Notice that since each of these lines is vertical, it is influenced by the vertical weight component, and is six points thick.

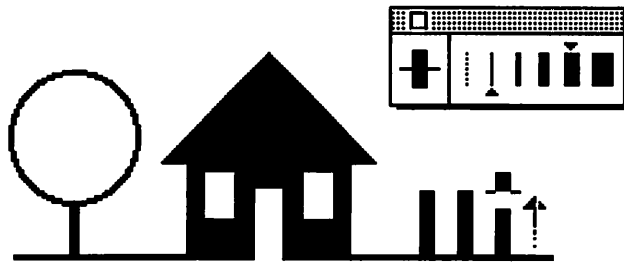

Create the three posts of the fence by pressing the shift key and drawing with the line tool. The line weight window displays our current component selections.

Now, without changing the line weight, press the shift key and draw four horizontal lines, each of which intersect the three vertical posts. Two of the horizontal lines should be positioned within one screen pixel of each other near the top of the posts; the other two should be positioned within one screen pixel of each other near the base of the posts. Notice that each of the horizontal lines is very thin, in accordance with the current horizontal weight component.

We want the 1-point space between the two pairs of horizontal lines to be white, so that each pair looks like a single slat. We will accomplish this by drawing a white 1-point line with the line tool between each pair of horizontal lines.

Drawing a colored or patterned line with one of the line or shape tools works differently in different applications. Many applications allow you to select a “Pen” pattern that affects a line or outline separately from the pattern used to fill a shape. In applications that allow you to select only one pattern at a time, you typically press the command key while drawing with the line tool to access that pattern.

Select the white “Pen” pattern, or press the command key (since the white fill pattern is already selected), and draw a horizontal line between each pair of existing horizontal lines while pressing the shift key.



Drawing a white line between each pair of black horizontal lines covers up small portions of the thick post lines, making our slats appear opaque.

The last step in creating the fence is to add a rounded tip to the top of each post. The easiest way to do this is to use the pencil tool in “fat-bits,” a common magnified view size.

Access the zoom tool—either by selecting it from the application toolbox or by selecting the pencil tool and pressing the command key—and click anywhere on the fence. Some applications magnify to “fat-bits,” which is eight times larger than the normal view size, by clicking only once. Others magnify the view size just two-fold each time you click with the zoom tool, meaning that you must click three times to access “fat-bits.”

After magnifying the view size, make sure that all of your posts are visible by dragging your screen image into position with the grabber hand tool. The grabber hand is accessed by pressing the option key or the spacebar, depending on your application.

Once the fence is entirely visible, select the pencil tool, if you have not already. Clicking with the pencil tool in “fat-bits” is a common method of creating and deleting dots to fine-tune an illustration. In our case, we want to create a series of six dots at the top of each vertical line, as shown in the figure below, rounding off the tops of the posts.

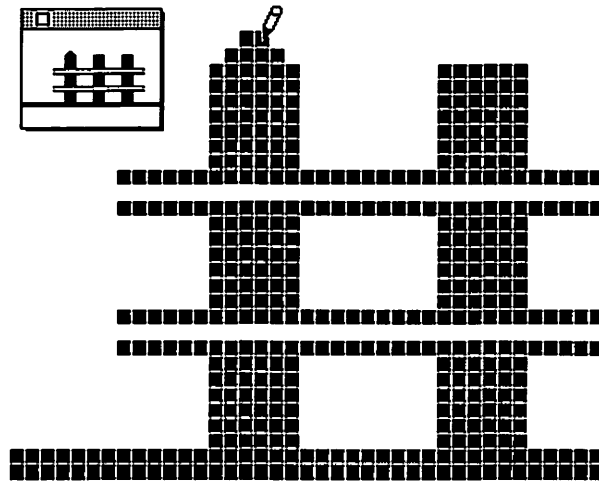

In “fat-bits,” click with the pencil tool to create a row of four dots and then a row of two dots centered above each post. The normal view size window demonstrates how this gives the post a rounded tip.

After you have given each post a rounded tip, return to the normal view size. You may accomplish this by clicking inside the normal view size window. If clicking inside this window only demagnifies the view size two-fold, click twice more. If your application provides no normal view size window, try pressing the command key and clicking with the pencil tool one or more times.

Notice now that all the elements—the house, the tree, and the fence—are complete. However, their positioning is not quite correct. We will use the lasso tool to bring all of the elements together.

First we will move the house and fence in relation to the tree. Select the lasso tool and lasso the house and the fence; do *not* lasso the tree! Since the tree and the house are connected by the ground level, you will have to drag through this line with the lasso tool. The lassoed elements will vibrate to indicate that they are selected. Press the shift key and drag the selected elements to the left, so that the roof of the house slightly overlaps the tree.



Drag the lassoed house and fence to the left, moving the elements until they partially overlap the tree. The arrow shows the direction of our drag.

Next, lasso only the fence. Press the shift key and drag this element to the left until it touches the house.

When you are finished positioning the three elements, the icon is complete. The only remaining step is to clean up the illustration. For example, you may need to fix some corner of the house or some other detail using the pencil tool in “fat-bits.” The ends of the slat lines on your fence may not be flush with each other. In short, your drawing may have several problems, or none at all. This is the time to clean them up.

In our case, there is only one problem: the ground level line extends beyond the end of the fence. To remedy this, we select the eraser tool and erase along the edge of the fence.

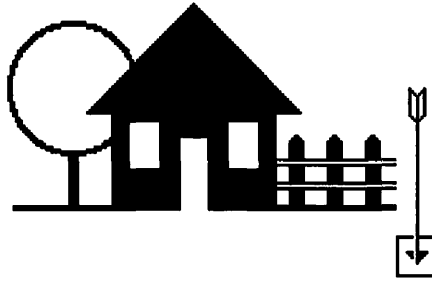

We use the eraser tool to clean up a minor imperfection in our icon.

Your page ornament is now finished. If you have not already, you should save your drawing to disk for future use or for importing into some other, non-painting application. If you would like to see your drawing on paper, print the file to your ImageWriter or laser printer.



This ends our first basic sample project. We have demonstrated how to create a typical page ornament using the line, rectangle, and ellipse tools. We have also discussed how to apply line weights, how to use the solid black and white patterns, how to use the pencil tool in “fat-bits,” and how to select and move elements with the lasso tool, in the process of building three simple forms.

When creating page ornaments of your own, remember to keep your drawings as simple as possible. They should also be easily recognizable, yet generic enough to be used over and over again. Finally, try to sketch the basic form of your central shape and then work outward. This will save you time, and help you to avoid the frustration of having to redraw fundamental graphic elements.

In our next project, we will use more basic tools and techniques to create a simple cartoon.

Creating a simple cartoon

Our second project in this chapter is to create a simple cartoon. Cartoons can be very useful to brighten up an otherwise dull page in an informal document, or to draw attention to a humorous article. We will be creating a cartoon of a bland-looking character unenthusiastically holding up his index finger with the caption “We’re number one,” coupling a powerful phrase with a singularly unpowerful looking person.

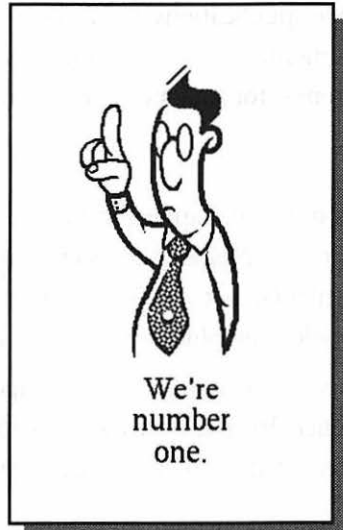

Our second sample project is to create this deadpan cartoon character.

In many ways, a cartoon is the opposite of a page ornament, the subject of our previous sample project. Rather than being generally appropriate for a wide variety of documents, a cartoon has a more specific purpose, making it exactly appropriate for some projects and very inappropriate for others.

The sample cartoon we will be creating may have at first appeared intimidating, rather than simple. But as you will see, there is very little to draw in this graphic. Many features are repeated over and over again, decreasing both the degree of difficulty and the amount of time required to complete the project.

In this project, we concentrate primarily on using the paintbrush tool. The paintbrush is very versatile, since you can alter the cursor by changing the brush shape, and because you can paint in any gray value, color, or pattern. Each figure in which we use the paintbrush contains a small window that displays the brush shape, and below that, another window displaying the selected pattern.

The first portion of our character that we will draw is his head. The shape that we create for the head is very important, since we will later be copying and transforming it to create the character's nose, fingers, and thumb.

Double-click on the paintbrush tool in your application toolbox to bring up a dialog box offering a variety of brush shapes. The currently selected brush shape is typically surrounded by a heavy square border. In our case, we want to select the brush shape that looks like a small round dot, as shown in the upper window of the following figure. Although this brush shape is probably already selected in your dialog box, you must click on it to return to your graphic. (If your brush shape dialog contains an OK button, you will also have to click it to exit the dialog box.)

After you have selected the brush shape, make sure that the solid black pattern is selected. Then draw the pickle-shaped outline shown in the figure below using the paintbrush tool.

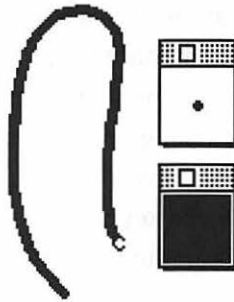

Draw the basic form of our character's head using the paintbrush. The brush shape (upper) and pattern (lower) windows display our current selections.

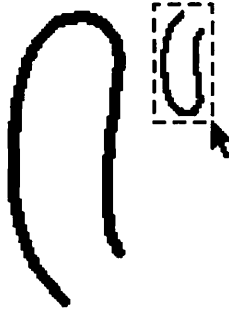

Pressing the command key and dragging at a corner of a marquee allows you to scale a selected object. Here we reduce the nose to a more reasonable size.

While the nose is still selected, choose the “Copy” command. This transfers a copy of the selected element into the Macintosh Clipboard. We will retrieve the copy later when we create the hand.

Before we drag the nose into place, we will create our character’s eye-glasses. Because one lens is behind the nose and the other is in front, it is easier to put the glasses and nose together before moving them on the face.

We will first create the bar of the glasses that goes over the bridge of the nose. Select the paintbrush and draw a slightly curved line joining both ends at the top of the nose, closing the shape off so that its interior is completely enclosed.

Next, we draw the glasses. To create the first lens, select the 2-point line weight. Then select the ellipse tool. Draw a relatively tall, thin oval, about the same size and proportions of the nose.

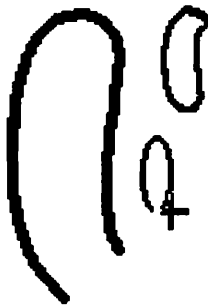

Draw the first eye with the ellipse tool, giving it a 2-point line weight.

The only feature that remains to be created on the face is the mouth. Select the pencil tool and draw a very small, frowning mouth starting at the left side of the face as shown below.



A small, downturned mouth on our character makes him appear sympathetic, yet not unhappy.

To create hair, we could draw a bunch of little lines on the top of our character's head using the pencil tool. However, this would not only be time-consuming, but—because of the limited resolution of a paint application—it would look muddy as well. An easier way to give our man a bouffant hairdo is to paint a thick pattern on his head with the paintbrush.

Using the brush shape dialog box as we described earlier, select the long diagonal brush shape. Then select the thick diagonal line pattern. (Both the brush shape and the pattern are shown in the following figure.) Finally, select the paintbrush tool and draw a wavy glob of hair as shown below.



Using the paintbrush with a diagonal brush shape and pattern shown in the windows, it is easy to draw a thick mass of wavy hair in one stroke. We also clicked once with the paintbrush just above the hair for extra flair.

Drawing simple wavy lines can be tricky, especially if you're new at using a mouse. If your first attempt doesn't work to your satisfaction, delete the stroke by choosing the "Undo" command immediately after you draw the line, and try again.

Our cartoon man is still missing ears. Luckily, cartoon ears are very easy to create, because your viewer won't pay much attention to them. Generally, any blob on the side of a head is assumed by the viewer to be an ear.

With this in mind, we will draw a quick ear with the paintbrush. The current brush shape is obviously wrong for ears, so reslect our original brush shape, the small, round dot. Then select the solid black pattern. Draw a half circle, a little smaller than the eyes, emanating from the right side of the head, flush with the bottom of the hair.

Then select the solid white pattern and paint over the segment of the outline of the head that lies between the head and the ear, effectively erasing it so that the two elements appear to be joined. Notice the advantage of using the paintbrush with a white pattern over the eraser tool; you can change the size of the paintbrush to fit into tight places.

Finally, select the solid black pattern again and draw a short line from the corner where the bottom of the ear and the head meet up and to the right to represent the fold of the ear.

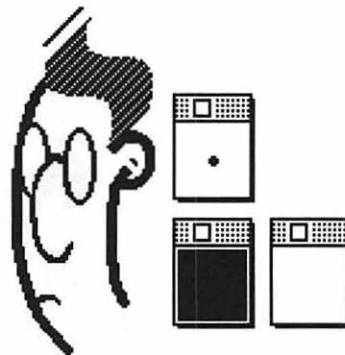

The ear is created by painting with both black and white patterns. The brush shape and pattern windows display our various selections.

The next few steps involve some more drawing with the paintbrush tool, using a variety of brush shapes. To create our man's collar, select the

very small, square brush shape and the solid black pattern. Then draw a triangular line of each side of his neck as shown in the following figure.

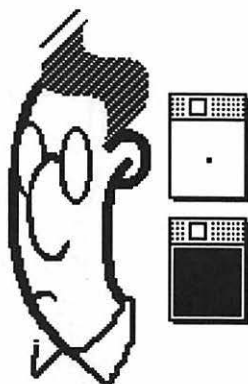

Draw the collar using the brush shape and pattern shown in the windows.

The tie is extremely easy to create. Select the largest round brush shape from your brush shape dialog box. Then select a garish pattern to go with this guy's flashy personality. Draw the knot of the tie by clicking just once with the paintbrush tool below the base of the neck, so that it fits snugly into the collar.

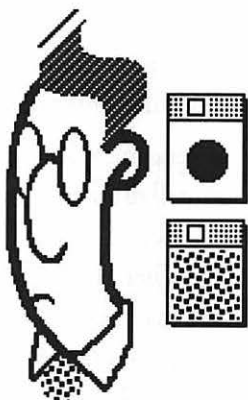

The knot of the tie is created by clicking with the large, round brush shape shown in the window. The lower window displays our garish pattern selection.

Next, select a smaller (not the smallest) round brush shape and draw in the rest of the tie. We recommend that you first draw the outline of the tie and then color in the rest.

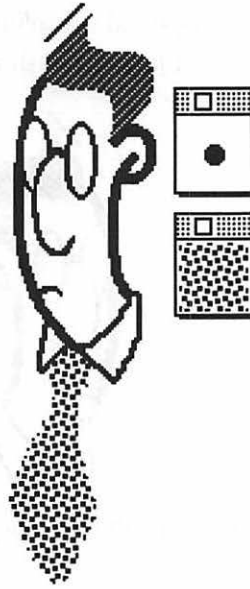

Draw the rest of the tie by creating its outline and then coloring it in. The brush shape and pattern windows display our current selections.

For the fun of it, we might as well give our man a tie clasp. Like the tie knot, this can be created by clicking once with a large brush shape. Select the second-to-largest round brush shape and the solid white pattern. Then click with the paintbrush in the center of the tie.

The next step is the lengthiest and most demanding drawing step. Using the paintbrush, we will draw the entire body of our cartoon character, including arms and paunch. Select our original small, round dot brush shape and the solid black pattern. Then draw the lines as shown below. If you make a mistake, remember to choose the “Undo” command immediately after the mistake is created. If you make a really big mistake, use the eraser tool, or paint over it using the solid white pattern.

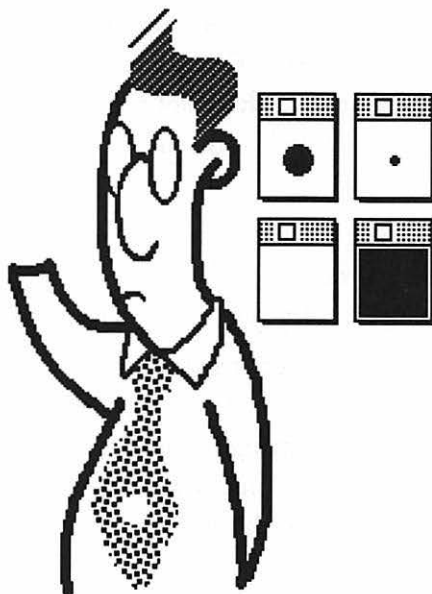

Using the paintbrush, we create the tie clasp and draw the body of our man. The right arm is drawn as a single arcing line, so it appears to be behind the back. The paunch is simply two arcing lines, almost symmetrical of one another. The left arm is the most difficult feature, since it is fully visible and gesturing upward. But even so, it is merely drawn as the combined result of three connecting curves. The two left windows display the brush stroke and pattern used to create the tie clasp; the two right windows display the brush shape and pattern used to create the body.

The only part of our cartoon character we have yet to create is his hand. Many beginning artists are intimidated by hands. The fingers are hard to draw correctly in relation to each other—especially the thumb—and it is often difficult to fit all of the fingers on the same hand. Also, hands are capable of complex movements difficult to render in a graphic.

Our hand is different. First of all, there is very little drawing required. Each of the fingers, including the thumb, will be created from an existing graphic element.

Remember when we copied the nose earlier in the drawing? Well, now we're ready to use it. Choose the "Paste" command and the nose will appear on your page, selected in a marquee. If necessary, drag the selected



Drag each of the fingers into position as shown above. For the sake of simplicity, our man has only three fingers.

The thumb is the last element to move. Think about how your hand looks when you point with your index finger. Your thumb covers the other fingers, holding them back. Our cartoon character's thumb must therefore be opaque, so that it may cover the two left fingers. This means that we must close off the thumb, just as we did earlier with the nose.

Select the pencil tool and draw a small line connecting the two ends of the outline of the thumb. The interior is now enclosed, as shown in the previous figure, so that it will be opaque when lassoed. Finally, select the lasso tool, lasso the thumb, and drag it so that it just covers the lower tips of the two left fingers.

Typically, clean-up is accomplished using the pencil in a magnified view size. Simply click on white areas to create dots to add to the graphic and click on black dots to delete them from the graphic. In our figure, we used the pencil tool in the “fat-bits” view size to clean up a number of slight imperfections. We added buttons to the cuff of our man’s sleeve; we got rid of extraneous lines in the hand; we added a thumbnail; we added folds to the sleeves; we cleaned up the ear; we outlined the tie and tie clasp; and we made alterations to the collar and forehead. All of these changes were made by carefully adding and subtracting dots in a magnified view size. These are the kinds of changes you can make to your graphic as well.

After you have executed whatever clean-up work you deem necessary, you should save your drawing to disk. And as before, you may print your cartoon to an ImageWriter or laser printer, or combine the graphic with text and other drawings in a non-painting application.



This ends the second of two sample projects included in this chapter. This project demonstrated how to use the paintbrush; how to change brush shapes; how to apply patterns; how to clone, copy, and transform one graphic element to use over and over in other situations; and how to think your way through an informal illustration.

The next two chapters contain more sample projects, with increasing levels of difficulty. If you feel that you have successfully completed this project and understand the techniques, tools, and commands covered, you will probably have little difficulty in moving on to the intermediate-level projects. If you feel unsure of any point that we covered, or are not satisfied with your work, you may want to re-examine earlier chapters, or perhaps try out some basic sample projects of your own.



Intermediate Hands-On Projects

This chapter is the second of three chapters that provide step-by-step explanations of the creation of specific graphics using a paint application. We discuss each of the features and methods introduced in Chapters 1 through 4 while working toward an actual goal. All projects are “hands-on”—demonstrating how to draw free-form computer graphics by requiring you to create the graphics yourself according to our specifications.

In this chapter, we will create two intermediate-level graphics: the silhouette of a human form and a company logo. Each project concentrates on fairly difficult aspects of graphic composition. If you have not yet completed the graphics in the previous chapter, we advise you to at least read through them at this time. By becoming familiar with the techniques, tools, and commands covered in Chapter 5, you will be more prepared to create the graphics examined in this chapter.

As the difficulty of our projects increases, it is likewise increasing important that you don't get hung up trying to match your graphics to ours dot-for-dot. As we mentioned in the last chapter, it is preferable that you try to work your own style into each project. By following our directions in a manner that seems comfortable to you, you may learn personal drawing habits that will help you when creating artwork in the future.

Creating a human silhouette

Our first intermediate project is to create the silhouette of a human form. Silhouettes can be very useful illustrations, since they are both realistic and relatively easy to create. They are well-suited to the paint environment, since they require little attention to small elements, such as eyes, ears, fingers, and so on. In addition, drawing a silhouette provides an opportunity for you to concentrate on the overall form of an object, without becoming overwhelmed by details that can not only slow down the creation of a graphic, but even detract from its appearance.



Our third sample project is to create this silhouette of a young girl.

Because silhouettes do not display facial features, they tend to be more generic, more useful in situations that display a typical person performing a typical task. By the same token, however, they do not elicit reader empathy. For example, suppose your company shares one or two photo copiers that seem to be constantly breaking down. A silhouette drawing of a copier repair-person would be the perfect accompaniment for an article on this subject in a company newsletter or memorandum. After all, repair-persons are probably a common sight in your building, but they are not in the company's direct employ and the article is undoubtedly not intended for their eyes. A silhouette basically tells the reader: you are not this person, but you know the function that this person serves the company, and he or she is somehow involved in this article.

Silhouettes also typically serve well as embellishments for "serious" publications, such as reports, directories, manuals, and so on, which require realistic graphics rather than cartoons or heavily stylized drawings. Since silhouettes can appear highly realistic without rendering large amounts of time and effort in their creation, they are the perfect last-minute graphic for a serious publication.



Above are some more examples of silhouette drawings. Each graphic is both realistic and generic, ideal for decorating a neutral, no-nonsense publication.

As always, we will begin our drawing by creating a central sketch and working outward. Our silhouette is a much more naturalistic form than either the page ornament or the cartoon that we created in the previous chapter. However, sometimes the easiest way to create a naturalistic form is to start off with a geometric sketch, created using one or more of the shape tools. After the rigid structure is finished, it can then be softened using the pencil in a magnified view size.

We will begin our geometric sketch by creating the head. Select the ellipse tool and draw an oval as shown below.

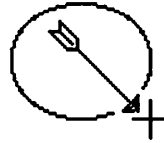

Draw an oval to represent the basic form of the head. The arrow indicates the direction of our drag.

This oval will act as the basic form of the skull of the silhouette's head. To this skull, we will add the general outline of the facial features using the polygon shape tool. The polygon tool is operated by clicking at various points on your screen, creating a connected series of straight lines as you go, one line between each click point. The polygon tool stops creating lines when you double-click or close the shape. Select the polygon tool and draw the profile shown below.



Using the polygon tool, we sketch the nose and jawline of the girl's face. Each corner in the outline of the face is a point where we clicked with the cursor.

A bow is tied into the girl's hair, so that it curls evenly into the back of her head. We will sketch this using the ellipse tool as well. Select the ellipse tool and draw a vertically oriented ellipse.

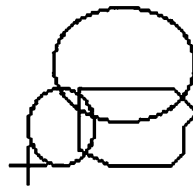

This second ellipse represents the bun of hair at the back of the girl's head.

The last feature of the head that we will sketch is the bow. Once again, we select the polygon tool for this task, and draw the shape shown below.

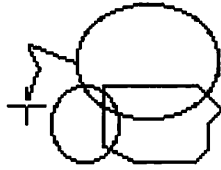

Sketching the bow with the polygon tool completes the silhouette's head.

Notice that throughout this quick sketch of the head with the ellipse and polygon tools, we have made no attempt to draw eyes, or a mouth, or any other incidental facial feature. This is because we are concerned only with the general outline of the human form, not any of its details.

The next step is to sketch the body. This is a little more difficult than the sketching we have done so far, since the body is made up of irregular shapes and protrusions. However, using the polygon tool, it is an easier task than it might be.

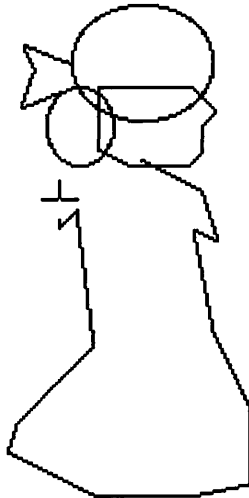

Draw the irregular outline of the body using the polygon tool. If you make a mistake, double-click to end the outline, choose the “Undo” command to erase it, and then try again.

Now that the basic form of the major portion of the body is completed, we have only to sketch the legs. In fact, we only have one leg to sketch, since the left leg is entirely hidden behind the right. In a normal illustration, it would be difficult to hide one limb entirely behind another like this and get away with it. But in a silhouette, we have more freedom to pick and choose what we want to draw, and what we want to leave to the viewer's imagination.

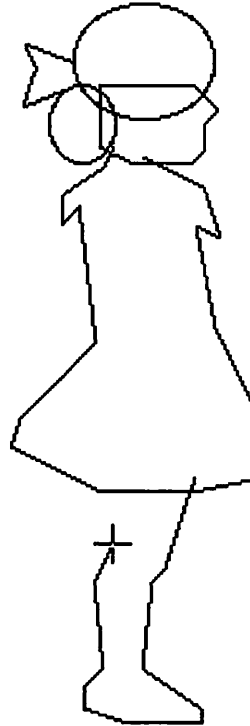

Sketch the right leg with the polygon tool as shown above. We don't need to worry about the left leg, since it is presumably so very slightly visible that it does not affect the basic form of the silhouette.

Our basic sketch is complete. You have probably noticed that some refinement will be required to make the sketch look less angular and more naturalistic. However, before we can perform these refinements, we must fill the silhouette sketch with solid black using the paint can tool. To prepare for

using the paint can, we should erase the overlapping line segments inside the sketch that create enclosed shapes that would prevent the paint from filling all portions of the sketch at once.

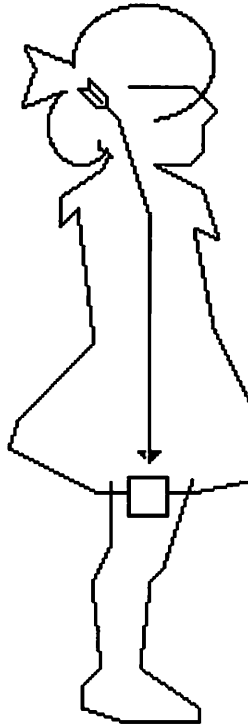

Using the eraser tool, carve away any line segments that form enclosed shapes inside the sketch and that would prevent the paint from flowing throughout. The arrow indicates the movement of our cursor.

Now select the paint can tool and make sure that the selected pattern is solid black. Then click anywhere inside the sketch. If your entire screen suddenly becomes black, this means that there was a break in the outline of your sketch. Choose the “Undo” command and then try to locate the break. You may have to look carefully, since a break may only be one pixel wide. Once you locate the break, fix it using the pencil tool in “fat-bits” and try filling the sketch again.



Fill the sketch with solid black using the paint can tool.

Before we soften the harsh corners of our sketch, we must fill in one remaining detail—the bow on the back of the girl’s dress. We skipped this feature earlier because it is more fluid than other portions of the silhouette, and it cannot easily be expressed as a geometric sketch. Instead, we will draw this form using the filled freehand shape tool, typically displayed in the application toolbox filled with gray. The filled freehand tool will enable us to create the shape and fill it in the same motion.

You draw with the freehand tool in the same way you operate the pencil tool, by simply dragging your cursor about the screen. If you are unhappy with the shape that you create, choose the “Undo” command and try again.



Drawing with the pencil tool against a black background creates a white line. This allows us to carve the outline of the shoe and sock.

If you have problems drawing smooth lines with the pencil tool in a normal view size, zoom in and then try to draw. It is often easier to draw with the pencil tool in a magnified view size.

Make sure that your lines extend off into the white area of the page, so that the three black areas that comprise the shoe and the sock are entirely isolated from each other and the rest of the silhouette. The reason for this is that we need to fill two of these black areas with white paint using the paint can tool.

After you have completed the shoe and sock outlines, select the paint can tool and the solid white pattern. Click with the paint can inside the main sock area, making it white. If the white leaks into other areas of the silhouette, such as the upper body or the shoe, you did not properly isolate these areas when creating the white lines with the pencil tool. In such a case,

choose the “Undo” command to return the silhouette to black, locate the dot or dots that are connecting the black areas, and erase them using the pencil tool in “fat-bits.” Then try to fill the sock again.

The other area that we need to fill with white is the portion of the sock showing through the top of the shoe. Click in this area with the pencil tool as well. Once again, if an additional black area becomes white, the area was not properly isolated, and you must try again as described in the previous paragraph.



Fill the two areas of the sock with white using the paint can.

We will be adding one more reversed detail in a few moments. But first, we need to add some black details. For example, notice the girl’s hair. Have you ever seen anyone with hair that perfect? Not a single strand is out of place. Not only is this unrealistic, it is also unaesthetic; it makes her hair look as if it were heavily greased down, or perhaps clamped tightly by a hairnet.

In order to make the hair more realistic, we will use a technique called dissipation. Dissipated areas of a silhouette are soft edges where black and white dots interact, demonstrating that there is no harsh edge to the form at this point.

Select the spraypaint tool and select the solid black pattern. Then click sporadically with the spraypaint tool directly underneath the hair in the area behind the girl's neck, creating a fine mist of dots as shown below. Also, spraypaint below the hem of her dress. These dots will be used to represent a small portion of the girl's slip.



Click repeatedly with the spraypaint tool to create a mist of black dots under the girl's hair and under her dress.

At this point, these mists of dots look like mists of dots. They do not look like hair or the lace of a slip. This is where the pencil tool comes in. Once again, we must zoom-in to “fat-bits” and manipulate the dots until they begin to resemble the objects they are intended to represent. Generally,

this is accomplished by drawing several short white lines through the clusters of dots. Occasionally, these white lines can even extend into the solid black of the silhouette.



This is our girl after we have refined the mist of spraypainted dots by drawing white lines into them with the pencil tool. This dissipation technique is most clearly displayed in the hair, where white lines extend into the solid black of the silhouette.

Now that we have added some dissipation to our silhouette, it looks even more realistic. The hair, for example, doesn't look noticeably less well-combed than before; it simply looks softer, more gentle. The slip, too, though not an essential addition, adds a spark of imperfection that heightens the realism of the overall form.

Our final step is to create one more white detail, similar to the sock. This time, we will add a white glove hanging at the girl's side, the finishing touch to her formal Sunday attire. Using the pencil tool, draw a white

outline of the general form of a hand, as shown in the figure above. As you can see, the hand is not very detailed, so you probably won't find it very difficult to draw.

After you close the outline, select the paint can and solid white pattern, and click inside the glove to fill it with white.



Fill the enclosed area of the glove with white using the paint can.

This completes our drawing of the silhouette of a young girl. If you like, you can add a few more small details. For example, in the figure above, we have added a shine to the toe of the shoe.

If you have not already done so, you should save the silhouette to disk. If you want to see your drawing on paper, print the file to your Image-Writer or laser printer.

This ends our first intermediate sample project. We have demonstrated how to create a naturalistic form from a geometric sketch, how to use the polygon and freehand shape tools, how to create highlights against a white background, and how to dissipate form using the spraypaint tool in combination with the pencil in “fat-bits.”

Silhouettes grab reader attention without asking for reader empathy. They are most useful when you want to create a realistic graphic without expending a great deal of effort, making them exceptional graphics for serious publications on a tight schedule.

When drawing a silhouette, try sketching the form geometrically at first. Then fill the sketch with black and soften the harsh edges with the pencil tool. To enhance the realism, add reversed details. Finally, use the dissipation technique to indicate loose hair or lacy clothing.

Our next project will make use of intermediate tools and techniques to create a company logo.

Creating a company logo

Our second intermediate project is to create a company logo. This is a departure from our previous projects in the sense that it is more of an experiment in using special effects than a drawing exercise. Logos typically require little drawing. Instead, they consist primarily of text, manipulated in some distinctive manner to impart a specific company image. The logo that we will create displays the company name, “WorldWide,” in stretched letters mounted on a patterned globe.

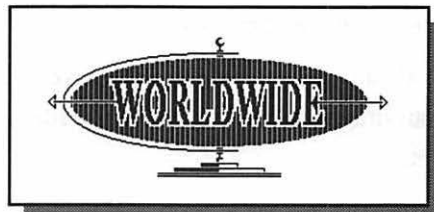

Our fourth sample project is to create this logo of text on a globe.

The three main advantages of logos over other types of graphics are:

1. They can be used repeatedly without any graphic alterations.
2. They can be used in both formal or informal publications.
3. They serve as graphic indications of a document's origin.

The best thing about creating a logo is that it is often a one-time experience. Once it is finished, you can use it over and over again without fear of audience reproach. Though viewers naturally tire of multiple exposures to a standard illustration, they are conditioned to repeatedly see the same logo; in fact, your readers may come to expect at least one version of your logo in every document that you publish. In fact, logos can be used more often than any other type of graphic, even page ornaments, making them a great time investment.

A logo is also an incredibly versatile graphic. It can embellish any document, from an informal newsletter to a legal contract.

Finally, a logo can be used to indicate a publication's origin. For example, suppose your company is large enough to support many departments or locations. A slightly different logo can be assigned to each division.



Different departments within the same company are commonly assigned slightly different logos. These logos can be used to graphically identify the origin of a publication.

Now to begin creating our logo: rather than sketching the logo, as we have begun projects in the past, we will start right in, for the basic form of the logo is not complex enough to warrant a sketch.

Generally, the first step in creating a logo is to create the logo text. Therefore, our first step will be to determine the type specifications by choosing typeface, style, size, and alignment commands from our software menu. First, change the font to Times. Then change the type style to bold, change the type size to 24-point, and change the alignment to center, or “Align middle.”

Next, select the text tool and click in the center of your screen. Since the text in our logo needs to be entirely in capital letters, press the caps lock key on your keyboard. Then enter the text “WORLDWIDE” all as one word. Press the caps lock key again to disengage it, so that it will not affect the rest of the creation of our logo. (The caps lock key has a tendency to act like the shift key in many applications, constraining cursor movement when pressed.)

WORLDWIDE|

Your text should look like this if properly set in centered 24-point Times bold.

As we discussed in *The text tool and font commands* section of Chapter 3, text in a paint program is just another graphic element that can be transformed and manipulated. In this case, we want to stretch our text so that it is about twice as tall as it is now, without changing the width, so that the text has a condensed appearance. Most paint applications do not provide grids or rulers, so stretching an element to twice its present height can be difficult to measure without first creating a constant.

A constant is an element that is created specifically to act as a reference for a transformation. In our case, we will create a constant that matches the height of the present text, then create a clone of the element and stack the two constants end-on-end to indicate the height of the stretched text.

Select the rectangle tool and create a shape exactly the height of the present text as shown in the following figure.

As we mentioned earlier, almost no drawing is required to create this logo. However, there are several fairly complicated special effects that we will need to perform. Along with this, we will frequently clone the text, allowing us to transform the clone, then return to the original and transform it in some different manner, and then combine the two transformations.

With this in mind, select the lasso tool and lasso the text. Then press the shift and option keys, allowing you both to constrain your movement and to create a clone, and drag downward about an inch. Now we have two blocks of text, one located directly below the other. For now, we will leave the upper text block alone. But in a few moments, we will subject it to a number of transformations. The lower text block, however, will serve as a marker for the next shape that we create, the large oval that is an integral part of our logo.

Before we create the logo, we must create a special pattern with which to fill it. Therefore, we must edit an existing pattern. Double-click on any pattern, except solid black or white, or select a pattern and choose the “Edit pattern” command. Some applications also allow you to select a blank pattern to edit, so you don’t have to destroy an existing pattern in order to create a new one.

After the pattern editing dialog box appears, click inside the left-hand box in order to add and delete dots until you create the pattern shown below.

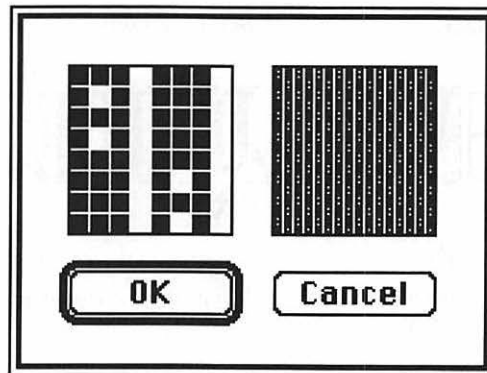

The pattern editing dialog box allows you to click in the left-hand box in order to add and delete dots to a pattern. The right-hand box displays the pattern as it appears at the normal view size.

After you have successfully created a pattern that matches ours, click on the “OK” button to exit the dialog and enter your pattern into the pattern library. Or, if you really have problems, you can click on the “Cancel” button to eliminate your changes and then try again.

Select your new pattern if it is not already selected. Then select the filled ellipse tool. Also select the invisible line weights so that no line appears around the oval in our logo. Using the ellipse tool, draw a wide oval that completely encompasses the lower text block.



Draw an oval with the filled ellipse tool around the lower text block, as shown above. When you have completed the shape, it should automatically fill with our new pattern, concealing the lower text block entirely.

Notice that we have now lost the lower text block. This is not a problem, since its only function was to help us to align the large oval. The upper text block should still be entirely visible. If any part of it is covered, choose the “Undo” command and draw the oval again.

Eventually, the text block needs to be set into the patterned oval. We could simply select the text and drag it onto the oval, but it would be very difficult to see, due to the darkness of the pattern. Instead, we want to create a white border between the text and the pattern, ensuring that the type is both legible and aesthetically appealing.

Creating this white border around the text requires several transformations. First, we will clone our remaining text block so that any transformations we perform will not diminish its appearance, since we will also

need it intact later. Select the marquee tool and loosely marquee the text block; there should be at least one-eighth inch of white space surrounding the text inside the marquee. The next transformation that we will perform, tracing edges, requires a margin of room inside the marquee in which to operate.

After marqueeing the text, press the shift and option keys and drag directly downward past the oval, cloning the text.

While the cloned text is still selected, choose the “Trace edges” command twice, observing the transformed text after each operation. (A few applications do not have a “Trace edges” command. If yours does not, there is unfortunately no way to simulate this effect, and you will have to just follow along with our text for the remainder of the project.) Notice how the text effectively becomes fatter with each new outline. As you will see, this is the first step in creating the white border around our text.

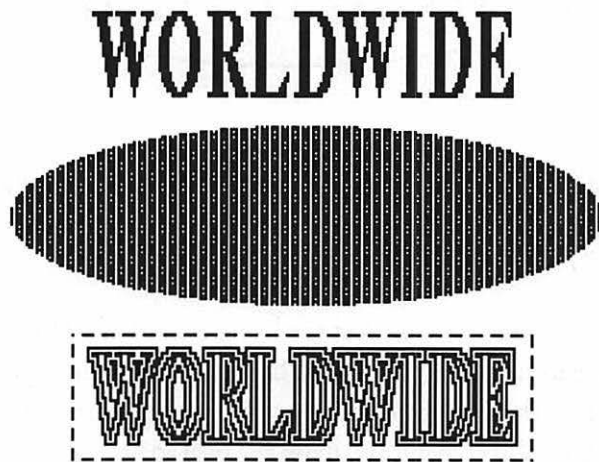

Repeated applications of the “Trace edges” command expands the girth of the selected element.

We still need to perform a couple more transformations to this text block before it is suitable as a white border for our logo. But before we perform these transformations, we must again clone the selected text block. This outlined text will be useful for another step that we perform near the end of this chapter.

Press the shift and option keys and drag the selected text block directly downward about an inch, creating a clone. Our next step is to transform this clone from a mass of competing outlines into a solid white border. The commands that we will demonstrate in this step are the “Fill” and “Invert” commands.

Generally, the “Fill” and “Invert” commands work better if an element is lassoed rather than marqueeed. Select the lasso tool and reselect the bottom-most text block. Next, select the solid black pattern and choose the “Fill” command. This fills the entire text block with black, eliminating the many outlines.

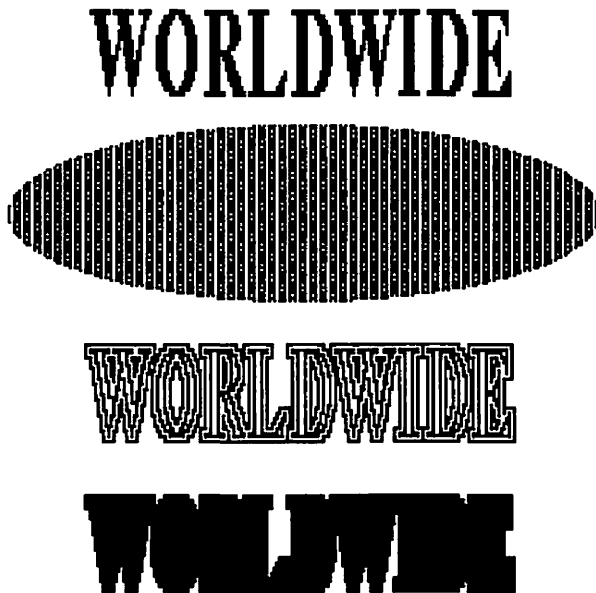

Transform the bottom-most text block to solid black by selecting it with the lasso tool and choosing the “Fill” command.

Our text block is now fat and black. It is also hopelessly illegible, but since it will only be acting as a border, this is not a problem. However, we do need to change the type from black to white, since our border needs to be white. This may make you wonder why we didn’t select the solid white pattern before we chose the “Fill” command. The reason for this is that the text would be white against a white background, making it impossible to see

Our logo looks pretty good. Our original type is surrounded by a white border which is itself surrounded by a patterned oval. Unfortunately, however, our white border isn't quite consistent. For example, the inside of some letters, such as the O and the D's, as well as some spaces between letters, like that between the R and the L, are completely white. For a consistent appearance, there should be patches of the patterned background showing through in these areas. Our next step is to create these patches of pattern and insert them into the logo type. This is where the outlined text block comes into play.

Select the paintbrush tool and the solid white pattern. Using the paintbrush, erase all portions of the outlined text except those innermost shapes that represent a bit of pattern that should be showing through. In case you are unsure of which shapes these are, refer to the next figure.



The outlined shapes inside the lasso are what remains after erasing the larger outlines with the paintbrush. Each of these shapes represents an area of patterned background that should be showing through the white border of the logo.

This last step was as difficult as this project gets, since there is quite a bit of fine detailed work involved in erasing around the innermost outlines. If you have any problems, you may try erasing some lines by using the pencil tool in a magnified view size.

Select the lasso tool and lasso the small shapes under the logo. In order for the patches of pattern to fit correctly into their respective logo letters,



We have added some detail to the logo, enhancing its impact and appearance.

This completes our drawing of a company logo. You should save the logo to disk if you have not done already. If you want to see your drawing on paper, print the file to your ImageWriter or laser printer.

This ends our second intermediate sample project. We have demonstrated how to create an abstract form about a central text block, how to edit a pattern, and how to transform graphic elements using the “Trace edges,” “Fill,” and “Invert” commands, and we have demonstrated when these commands are useful.

Logos are among the most useful graphics, due to their exceptionally long lives, their versatility, and their quick distribution of information. In general, we recommend that a logo accompany every document that you produce, whether it appears as a boxed item at the bottom of a page or as a personal letterhead.

In this sample project, we not only executed a logo, we also designed it. When you create a logo, however, you may find yourself working from an existing design, either simply executing it in an electronic environment or embellishing it to represent the identity of your specific department. In either case, the approach is the same; the type is always the central graphic object.

The following chapter contains an additional sample project at an advanced level of difficulty. If you feel that you have successfully completed the previous projects and understand the techniques, tools, and commands

covered, you will probably have little difficulty in moving on to the next chapter. If you feel unsure of any point that we have covered, or are not satisfied with your work, you may want to re-examine Chapters 1 through 4, or perhaps try out some sample projects of your own.

An Advanced Hands-On Project

This chapter is the last of three chapters that provide step-by-step discussions examining the creation of specific graphics using a paint application. We discuss each of the features and methods introduced in Chapters 1 through 4 while working toward an actual goal. All projects are “hands-on”—demonstrating how to draw free-form computer graphics by requiring you to create the graphics yourself according to our specifications.

In this chapter, we will create a single advanced-level graphic: a realistically rendered voluminous object. This project concentrates on the most difficult aspects of graphic composition. If you have not yet completed the graphics in the previous two chapters, we advise you to at least read through them at this time. By becoming familiar with the techniques, tools, and commands covered in Chapters 5 and 6, you will be more prepared to create the complex graphic examined in this chapter.

Well-executed, realistic drawings are useful in every publication. Therefore, regardless of your subject matter, a realistic drawing approach is always acceptable. However, creating a realistic drawing also consumes more time and energy than creating other types of drawings, so you will probably only want to pursue realism when it is absolutely necessary. Realism is generally absolutely imperative only under the following circumstances:

1. When creating a portrait to accompany an article about a person for promotional or informational purposes.
2. When rendering an illustration of a product distributed by your company.
3. When the subject of a story is very serious in nature. The most serious subjects can generally best be rendered realistically.

Creating a stylized graphic for any of these topics might make your publication less effective.



Each of the three types of drawing shown above—portrait, product illustration, and serious-subject graphic—require a realistic drawing approach.

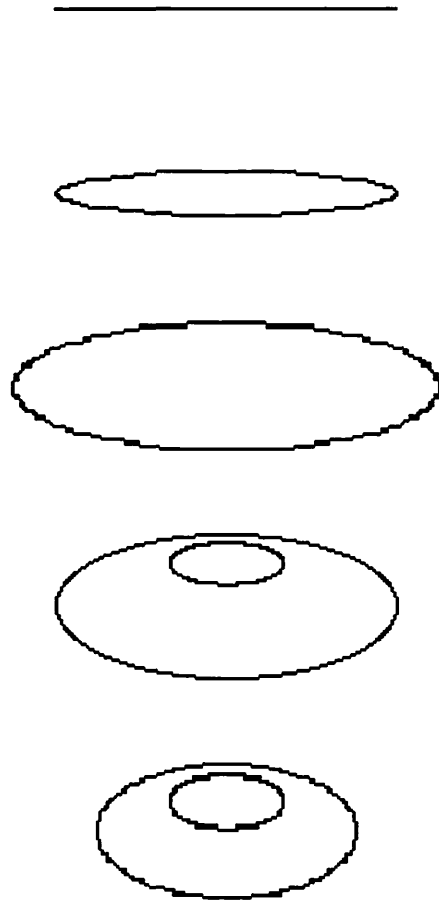

Scale the second-to-top and bottommost ovals proportionally to more accurately represent the cross-sections of the lamp. We also add smaller ovals inside the bottom two ovals to represent cross-sections of the lamp stem.

The five main ovals shown above (including the horizontal line at the top) represent, from top to bottom, the very top of the lamp, the top of the lampshade, the bottom of the lampshade, the top of the body of the lamp, and the base. We will now connect these shapes to make them more recognizable.

Using the line tool, draw a vertical line the height of the entire lamp. The line should be located about one-eighth inch inside the right edges of the two smallest ovals, and represents the right side of the lamp stem.

Then, draw in the right side of the lampshade and the right side of the body using the pencil tool.

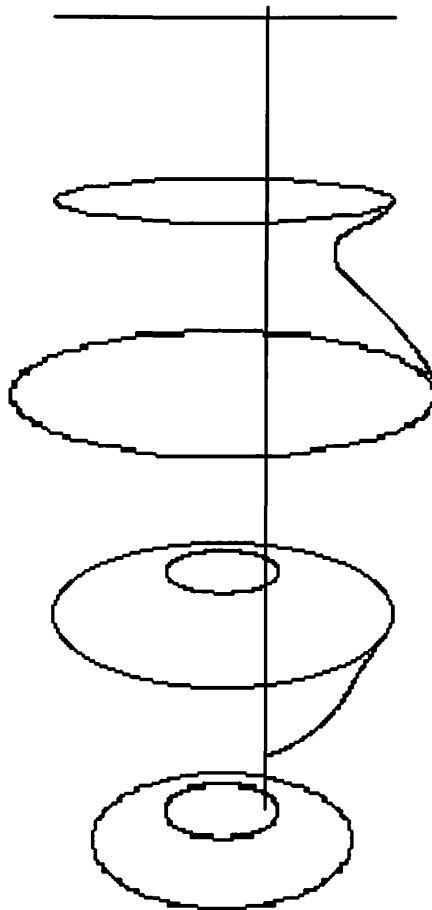

Sketch in the right edges of the stem, lampshade, and body of the lamp.

The reason we drew only the right edges of the various portions of the lamp is because the lamp is symmetrical. This means that we can flip the lamp horizontally to represent the various left edges. Marquee only the right side of the lamp, drag a clone of it to some empty portion of your screen, and choose the “Flip horizontal” command for the selected clone. Then, lasso the flipped lamp and drag it so that it lines up perfectly on the left side of the original. (Objects are generally easier to line up when they’re lassoed.)

The two small ovals surrounding the lamp stem are the outer edges of two rings. Using the ellipse tool, draw a smaller oval centered inside each to represent the inner edges of the rings.

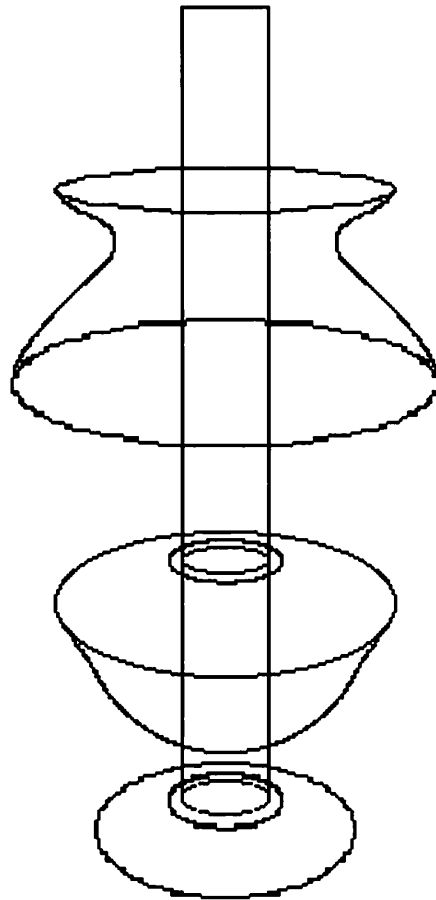

By flipping a clone of the right side of the lamp horizontally and adding two additional small ovals, we complete the first phase of our sketch.

This completes what we can basically call the first phase of the sketch. Notice that the basic form of the lamp is blocked in. Next, we will begin sketching in the shading, which is a fairly time-consuming task, though not extremely difficult.

Before we begin shading, however, we should clean up our sketch. Our present lamp appears to be made out of glass. We can see through the shade to the stem, through the stem to the base, and so on. In order to make the lamp seem like a solid, physical object, erase all of the lines that should be hidden by other portions of the lamp. You may use the eraser tool, or select the white pattern and erase with the paint tool, or use a combination of both.

Now, to sketch in the shading. Before you can determine how to shade an object, you must determine a light source. In our next figure, we have drawn a detailed light bulb to represent our source, although it is not necessary that you do so. You can indicate yours simply as a circle. Incidentally, we could have the lamp illuminate itself, as they often do, but we can achieve a more interesting result by utilizing a foreign light source.

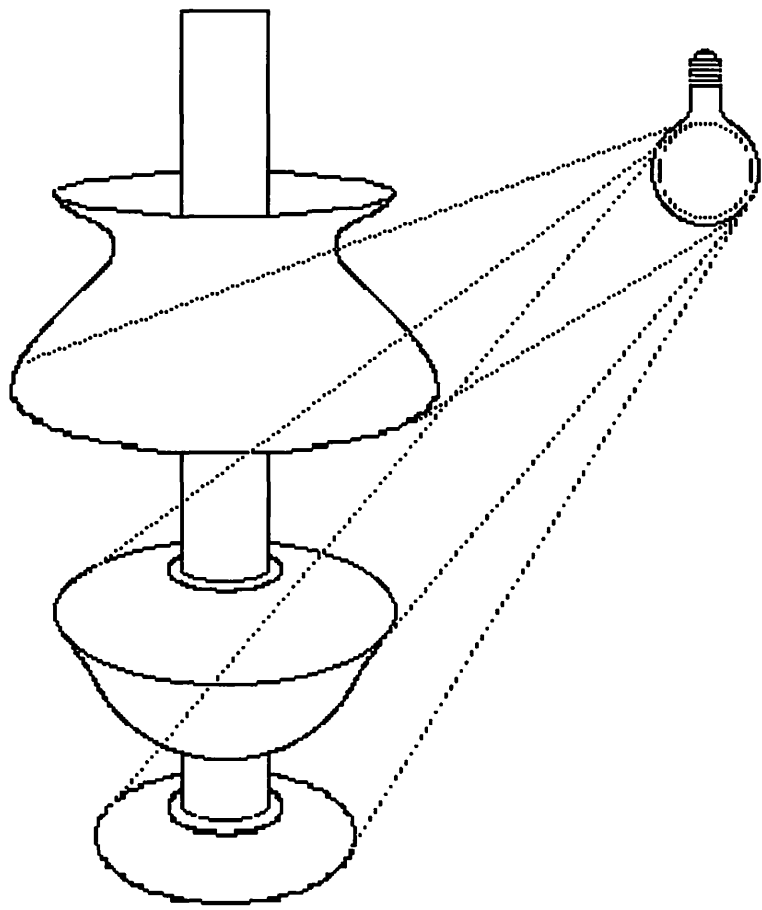

Indicate a light source and sketch lines from it to key parts of the lamp.

Once you have indicated your light source, sketch lines from the outer edges of this circle to the surface of your lamp. These lines signify the angle at which light hits different portions of the lamp, helping you to determine where the lamp should be lit, and where it should be dark. We drew our lines using the line tool and a light pattern. Keep in mind that the light source and lines are for reference purposes only, so they don't need to look good. We will erase them before the drawing is finished.

Next, sketch the border lines between the shaded and lit areas of the lamp as shown in the figure below.

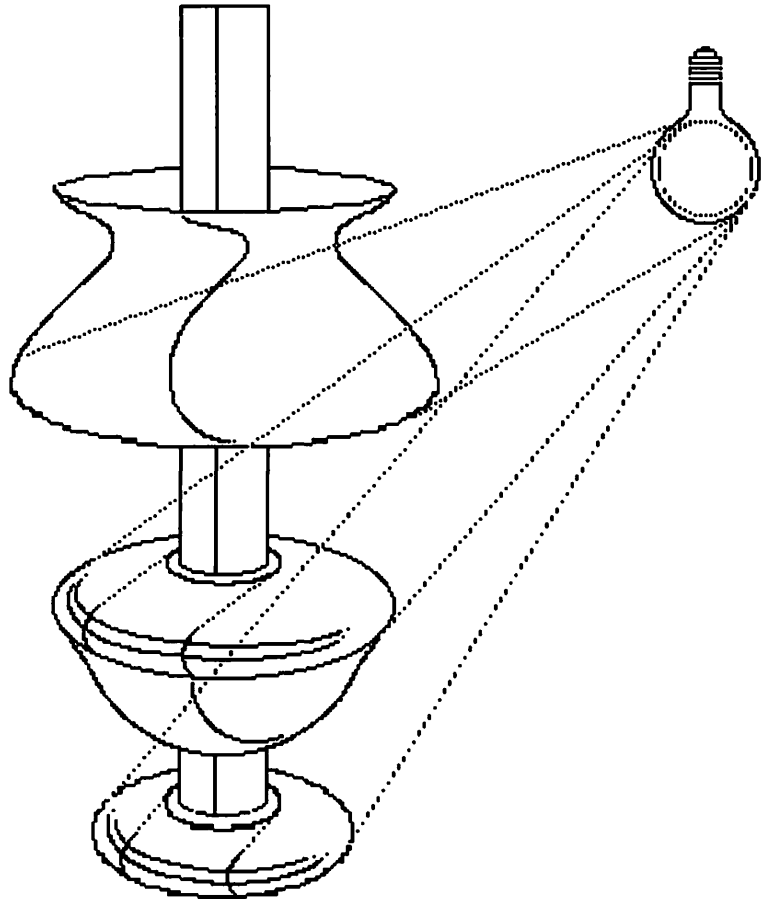

Sketch lines to represent the borders between the light and dark portions of the lamp. Notice that the shadows on the body and base from the stem of the lamp are parallel to the lines we sketched from the light source. This is an example of how these lines help us determine how to shade a voluminous object.

After you finish sketching the shading, clean up the sketch by erasing the light source and any reference lines from the source to the lamp. Now we are ready to create shading, using the paintbrush and spraypaint tools. Shading in a paint application is a process of laying down a series of gradually darkening or lightening patterns (including gray values and colors), one after another. In order for the shading effect to work, the patterns that you use must be compatible, as we discussed in Chapter 4. The lightest pattern should be designed to evenly flow into the second to lightest, which flows into the third-to-lightest, and so on. For our lamp, we will be using a series of line patterns. You should add each of the patterns shown below to your personal pattern palette.

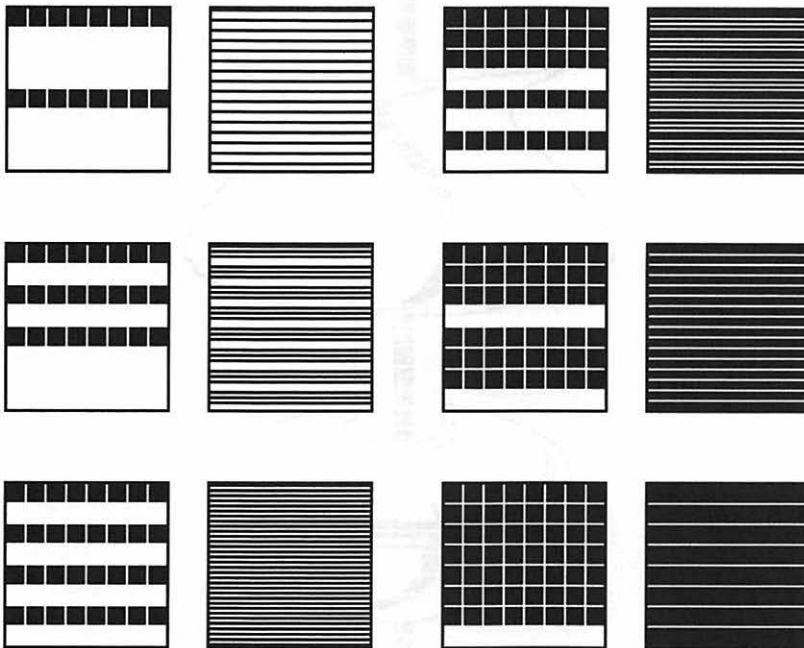

Above is each of the patterns, from lightest to darkest, that we will be using to shade our voluminous object. Each pattern is shown in a magnified and normal view size so that you can easily duplicate it.

Now to begin shading. Shading is a very unscientific process. No matter how carefully you determine your light source or sketch boundary lines, shading ultimately depends on the personal whims of the artist. You simply add what it seems should be there, subtract what seems incorrect, add some more, subtract some more, and so on, until the general effect of a voluminous form is believable.

We will add our first layer of shading with the paintbrush tool. Select the darkest of the line patterns we just created, and trace over the boundary lines as shown below.

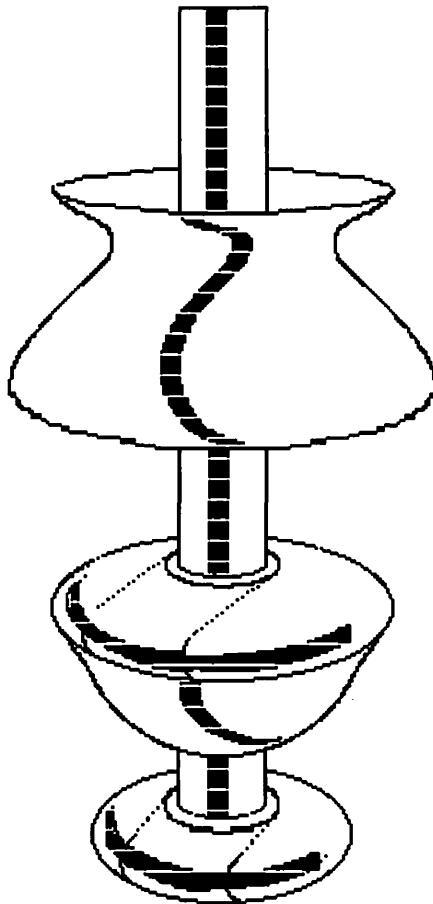

Painting over the boundary sketch lines with our darkest pattern is the first step in laying down shading over the surface of lamp. You may want to experiment with different brush shapes during this step. We used two shapes: a short vertical line and a short horizontal line.

Now, select one of the medium-density line patterns, and sketch in more shading around the borders. You should experiment with using both the spraypaint tool and the paintbrush with a very small brush shape for this step.

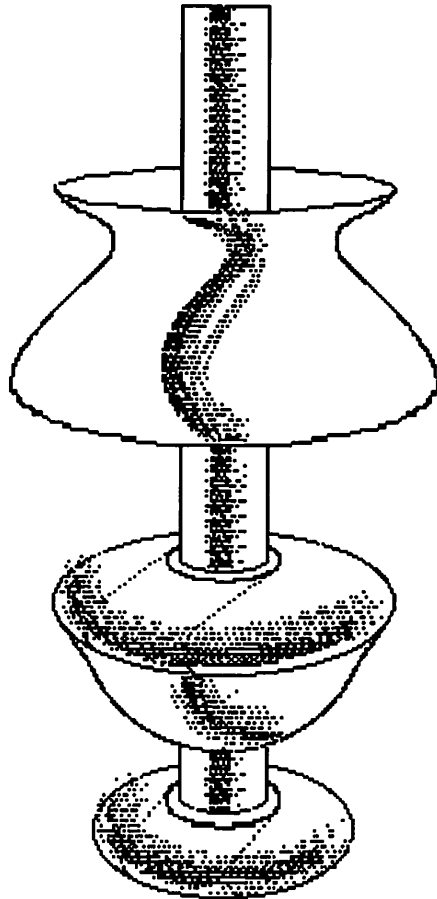

Sketch in a medium-value pattern to offset the intensity of the dark pattern.

Notice that we don't expend very much effort trying to paint exactly inside the lines. The outlines of our lamp are sketches only. They do not necessarily represent the locations of the final outlines, so they may be painted over fairly liberally, just so long as they don't become completely obscured.

In the next step, experiment with painting with all of the light pattern values. You should especially concentrate on filling in the left side of the lamp with shading, as demonstrated in the figure below.

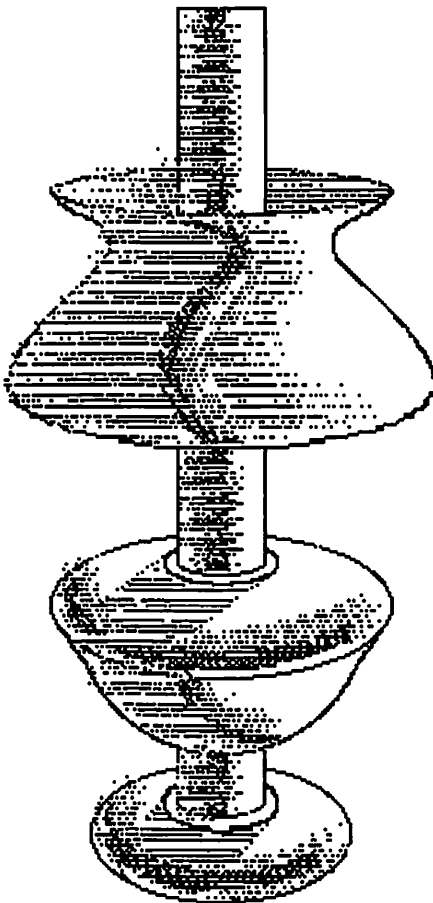

Fill in the left side of the lamp with light pattern values. Notice that we have filled in the shadows emanating from the stem onto the body and base of the lamp. We have also rounded out the appearance of the right side of the lamp shade using the spraypaint tool.

Generally, when shading an object, you can achieve interesting effects by using reflected light. This is a technique whereby the shading of an object goes from white to black to gray as it recedes from the light source, rather than simply becoming progressively darker. The idea is that the border area between the lit and unlit portions of an object receives the darkest shading, since light tends to reflect off the surfaces of the object's environment and back onto the object itself.

With this in mind, sketch in some darker shades around the border areas of the lamp using the spraypaint tool.

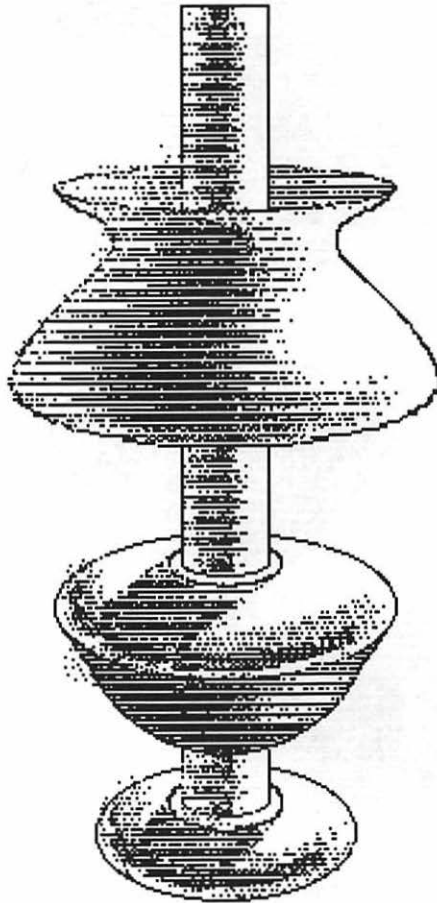

Concentrating on the border areas between the lit and unlit halves of the lamp, spraypaint in dark pattern values to give the form character and depth.

The next step is to define the surface upon which the lamp rests. Generally, lamps sit on flat surfaces which are easy to define. Again using the spraypaint tool, draw a round shadow to the left and slightly down from the lamp. You should sketch in dark patterns in the center of the shadow, and lighter patterns toward the edges.

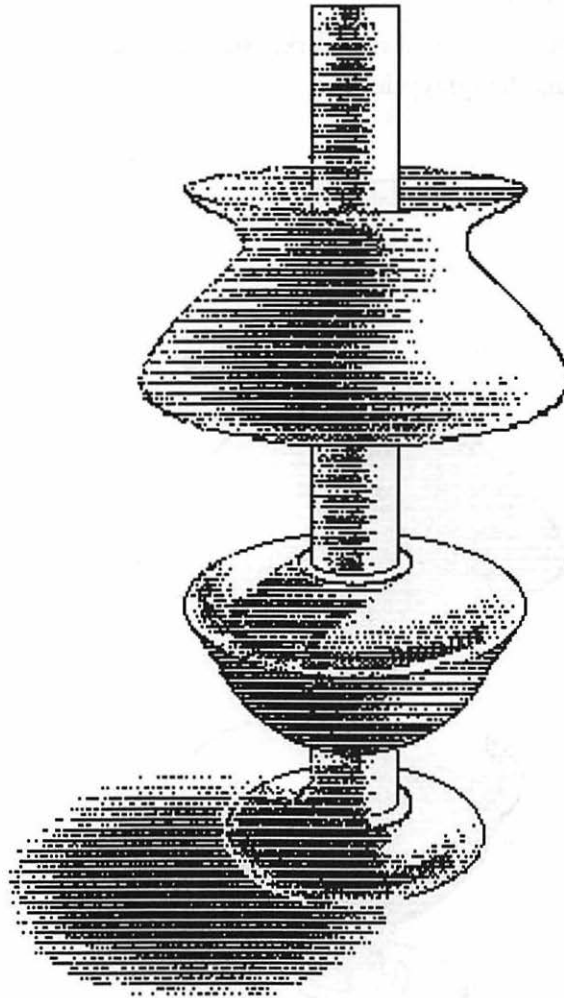

Draw in a round shadow beginning at the base of the lamp and continuing onto the table top. We also sketched a white line between the base and the table using the pencil tool, ensuring that the lamp does not become connected with its environment.

This completes our shading of the lamp. The only step left is to clean up our drawing so that it appears as a final graphic. As in the past, we accomplish this step primarily using the pencil tool in a magnified view size. Obviously, part of our clean-up must involve erasing the extraneous dots outside of the perimeter of the lamp. Also, we must clarify the outline of the lamp, making it heavier in the areas opposite the light source and thinner toward the light source. Below, you can see how our outlines have been cleaned up so they progress from very heavy to almost non-existent.

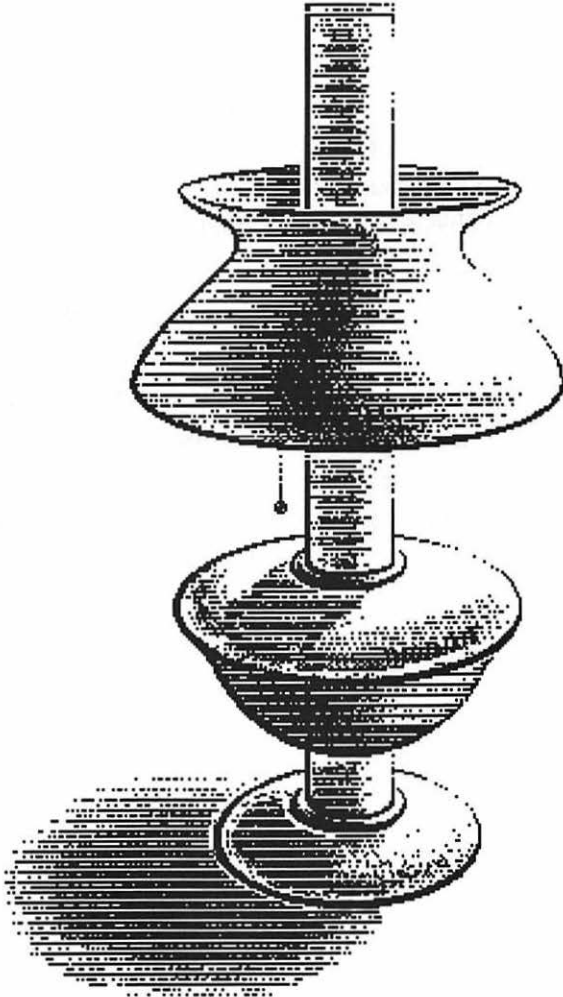

Using the pencil tool, we clean up the shading and outline of our graphic. Notice that we have also added the small detail of a pull chain.

This completes our drawing of a voluminous object. If you like, you can add a few small details or add or subtract some additional shading. Don't worry over it too much, however. Shading is supposed to look loose, and should not appear exacting or rigid like the outline of an object.

You should save the drawing to disk if you have not done so already. If you want to see your drawing on paper, print the file to your ImageWriter or laser printer.



This ends our advanced sample project. We have demonstrated how to create a realistic form using volume, light, and shadow. We have also shown how to determine the perspective of an object during the first stages of a sketch, how to determine a light source, how to sketch the border between the lit and unlit areas of an object, and how to build up the shading of an object using compatible patterns.

Realistic illustrations are the most useful, versatile, and effective graphics that you can create, but they are also the most time-consuming and the most difficult. For this reason, you will probably want to limit your use of realism to the necessary situations—portraits, product illustrations, and very serious graphics. You should always keep in mind that silhouettes are much easier to create than voluminous objects, and satisfy many of the same publication requirements.

Part 3

Drawing from Existing Artwork

Creating Illustrations Using Clip-Art

In previous chapters, we have discussed how you can combine a knowledge of drawing theory with an understanding of software tools to develop a successful drawing technique to create both simple and sophisticated illustrations. We have focused on skills that will help you to create custom drawings on your own, for your own purposes, from beginning to end.

But you don't always have to start from scratch. One advantage to electronic art is that it becomes a kind of commodity. For example, you can make copies of all of your artwork and trade it for an equal quantity of a fellow computer artist's work. This doubles your collection without requiring you to expend any extra effort. Now you have twice the resources on hand any time you begin a new graphic process, as described in Chapter 1.

*Artists can trade
electronic graphics
to build up their
libraries without
expending costs.*

A sizable library of artwork frees you to spend less time sketching ideas, so you can spend more time developing your technique and creating more sophisticated finished graphics.

One popular way to collect electronic drawings is to purchase clip-art, a common term for libraries of graphics sold on a commercial basis. The concept of clip-art has existed well before desktop publishing became popular. Most newspapers, for example, subscribe to monthly collections of clip-art. These are large-format magazines that contain pages and pages of camera-ready artwork that can be used for advertisements or editorial illustrations without paying royalties or hiring outside artists. The artwork tends to be generic in style as well as seasonal. In September, a clip-art collection is likely to contain many back-to-school drawings. In October, you can expect to see pumpkins, ghosts, witches, and so on.

The best clip-art is applicable to a wide range of situations. For example, a single graphic might appear in the same issue of a newspaper in three different advertisements.

The best clip-art is applicable to a wide range of situations.

The wise old owl reminds voters



to vote YES on Amendment #3



Just keep telling yourself...



it's only Halloween!

A single piece of clip-art can be used in many different situations.

The advantage of clip-art sold on a disk over traditional clip-art packaged in a magazine is that it can be more easily and more thoroughly customized. After all, a clip-art graphic will rarely satisfy your requirements exactly. Even if you're fortunate enough to own a large supply of clip-art and organized enough to go through what you have available in a reasonable

amount of time, you'll be lucky to find a graphic that almost meets your needs. Sometimes owning clip-art can be like subscribing to cable TV: despite a selection of over forty channels, how often do you find something you really want to watch? But unlike cable TV, clip-art can be altered to more specifically match your tastes.

*Clip-art images
sold on a disk
can be easily
and thoroughly
customized.*

If a traditional layout artist at a newspaper needs to modify a piece of camera-ready clip-art, he or she must first shoot a copy of the art using a photocopier or a camera to avoid ruining the original. If any special effects such as inverting or resizing are required (few other transformations are possible), they must be accomplished during the photographic cycle by a qualified camera person. The layout artist then performs detailed alterations using pen, ink, and white-out. Finally, the finished art is cut and pasted into place. The entire process is expensive and limiting, demanding tight organization and a patient production manager.

By contrast, electronic clip-art was invented to be modified.

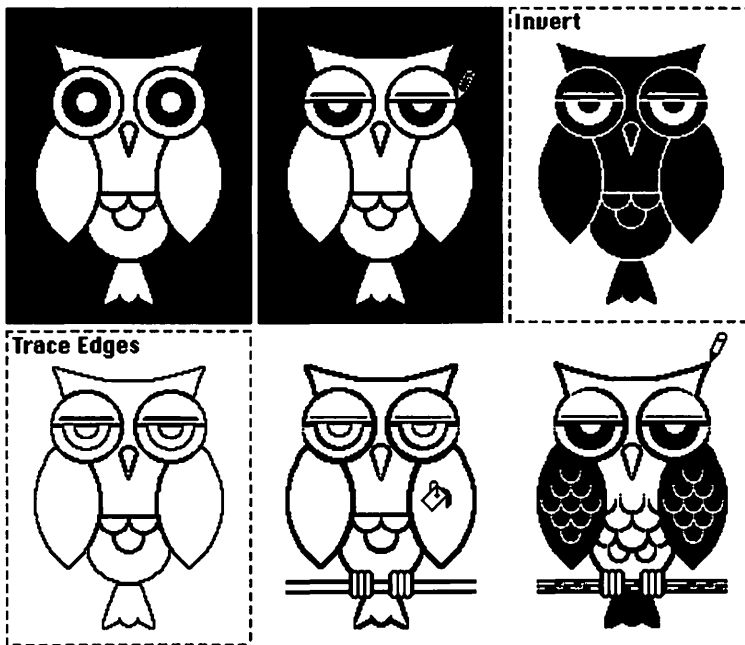

You can easily modify electronic clip-art to meet any graphic requirement. From start to finish, the above modification took about 15 minutes. We would have been better off starting from scratch if we had to perform the same modification by hand.

Modification is an instrumental step toward using clip-art to enhance your documentation adequately.

In all fairness, paint application clip-art has drawbacks too: it often has tiny jagged edges while traditional clip-art is utterly smooth and precise. But what a price you pay! Electronic clip-art can be modified in about a quarter of the time required to modify traditional clip-art, the range of modifications you can perform with your computer is virtually limitless, and the only cost you incur gets mixed in with the rest of your electricity bill.

Of course, you can use a piece of clip-art just as you find it. Sometimes, a purchased graphic suits a situation exactly. But generally, we find modification to be an instrumental step toward using clip-art to adequately enhance your documentation.

This chapter addresses three methods for manipulating clip-art:

1. How to customize clip-art to exactly meet your needs.
2. How to successfully combine multiple clip-art images.
3. How to mix clip-art images with your original drawings.

Before we get started, we should remind you that the following text is contains no advice regarding the purchasing of clip-art, nor is it a catalog of available clip-art. We merely provide assistance for using clip-art. Considering the literally hundreds of clip-art packages available, we must leave the purchasing and judging up to you. An appendix contains a list referencing the origin of each graphic used in our text along with vendor information. However, this is by no means a complete list of what's available; we include it only to give credit where credit is due.

Customizing clip-art

You can easily modify electronic clip-art to exactly meet your graphic requirements. We will prove this by demonstrating some of the most simple methods for enhancing clip-art, methods that produce dramatic results, yet require little time or energy.

Simple clip-art transformations

Sometimes the simplest transformations can change a piece of inadequate clip-art into precisely the graphic you've been looking for. Clip-art can be scaled, flipped, rotated, inverted, traced, slanted, distorted, colored, and so on, just like any other painted image. Such a simple fact is all too often overlooked by people who want to improve their documentation, but don't really consider themselves artists. Such a person might hesitate to alter a piece of clip-art for fear of ruining it. Fortunately, you need no artistic sensibility to perform many small transformations that change the attitude of an image without adversely affecting the precision of its form.



You need no artistic sensibility to perform transformations that change an object's attitude without affecting its form.

Here we have a piece of clip-art, based loosely on the enormous statue David sculpted by the Renaissance artist Michelangelo. Suppose this image is generally what we're looking for, but requires some transformations.

If a piece of clip-art doesn't exactly satisfy your requirements, change it.

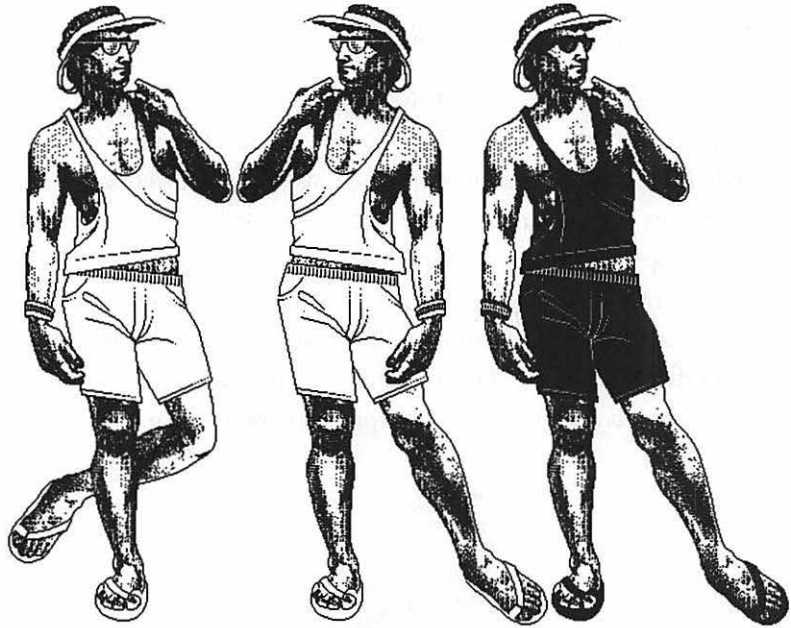

In each figure above, we have transformed one or more portions of our clip-art. We rotated the leg of the first David, flipped the torso of the second David horizontally, and inverted the clothing of the third David.

If a piece of clip-art doesn't exactly satisfy your requirements, change it. Small changes can be especially effective, yet require almost no time or talent.

Sometimes, a transformation can be accomplished by choosing a single command. But some special effects, while no more difficult, demand a little more time.

Modification hints and tips

You may recall that we disclosed a brief series of hints and tips in Chapter 4. We discussed how to make a line thicker without redrawing it, how to fill a shape with a custom interior, and how to add a shadow to an image. Each of these special effects methods is as applicable to clip-art as it is to your original artwork.

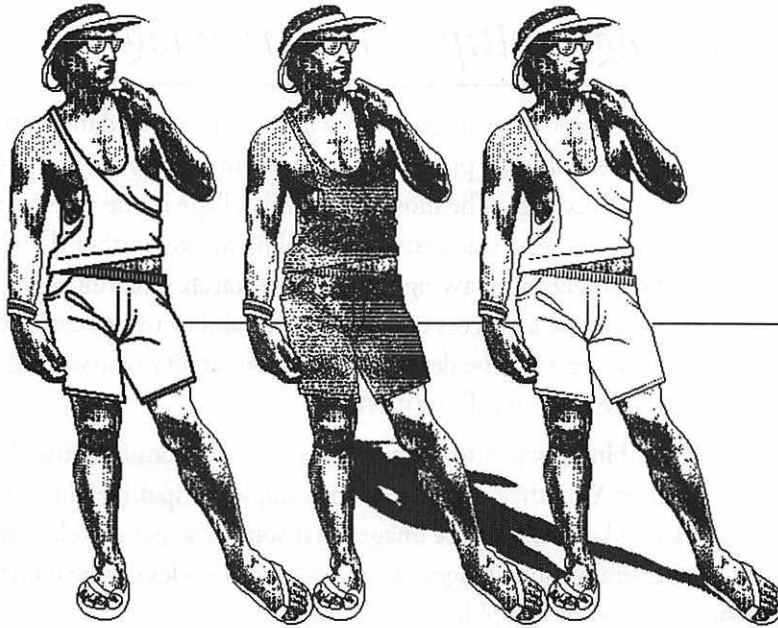

We have applied one of our hints and tips from Chapter 4 to each of the Davids above. We thickened the lines in the clothing of the first David. We filled the second David's clothing with a custom interior. We added a shadow to the third image. Even "high art" may be subjected to electronic enhancements.

Our special effects hints and tips from Chapter 4 may also be used to enhance clip-art images.

In this sense, our special effects hints and tips are really just extensions of the transformation commands included with your paint application. They are slightly more difficult to complete, but their results are more sensational and often more usable.

Any piece of clip-art may be dramatically altered or enhanced without drawing a single line, using your paint program's built-in transformation commands in addition to our special effects hints and tips from Chapter 4. In the next two sections of this chapter, we discuss how to perform even more extraordinary graphic enhancements by combining clip-art images with each other and with your own illustrations. The latter section explores how to use drawing theory to embellish a clip-art image.

Combining multiple clip-art images

Only images created in similar artistic styles can be combined into a single harmonious graphic.

Perhaps when you were in grade school, you participated in an art project that involved clipping pictures from different magazines and pasting these pictures into a collage. The most successful collage in the class was created by the student who was best at assembling images, rather than by the student who excelled at drawing them from scratch. Creating a graphic using clip-art is likewise a process of collage. Your ability to successfully combine clip-art images will be determined by your ability to assemble images into a single, cohesive illustration.

When combining separate images, you must first consider how they will look together. Will they merge to form a single compatible illustration or will they look like two separate images that somehow got too close to each other? Generally, only images created in similar styles can be combined into a single harmonious graphic.

Determining similar clip-art styles

In Chapter 1, we discussed how you can develop your own personal artistic style to enhance the successfulness of your graphics. In the process of developing a style, you may copy the styles of a variety of established artists, but ultimately your style must be your own.

So in a sense, styles are like snowflakes; no two are identical. However, if you can pinpoint enough stylistic similarities between two images, then you may in turn combine the images into a cohesive whole. The trick is, how do you recognize when two styles are similar enough?

First, if two clip-art images appear to be created by the same artist, then they can be combined. This is because, theoretically, an artist only has one style.

Some clip-art vendors are very small. The fact that the desktop publishing industry has yet to fully grow out of its grass-roots origins means that there remains room for the little guy. It is not uncommon for an artist to single-handedly create and sell personal graphics as clip-art. Other vendors purchase images from only a handful of free-lance artists. You may therefore easily combine different pieces of clip-art obtained from small developers.

You may easily combine different pieces of clip-art obtained from small developers.

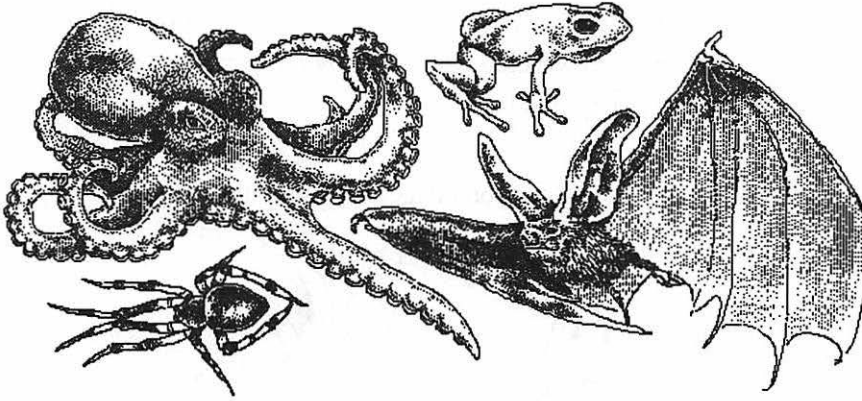

Each of these clip-art animals was drawn by the same artist. Since the artistic style of all four images is identical, they may be combined within a single illustration.

Unfortunately, as a market grows, the little guy either grows into a big guy or gets squeezed out entirely. This means small clip-art developers are becoming less and less popular. But regardless of how sympathetic you may or may not be to their dwindling numbers, you have to be suspicious of the questionable quality of their products. Don't get us wrong; some small art houses produce exceptional work. But you have to be careful; there is no guarantee that an artist can draw a straight line just because he or she sells clip-art. Some small vendors remain small because they produce inappropriate or unappealing graphics.

In all probability, most clip-art you buy will originate from an art warehouse, from a vendor who owns stockpiles of art collected over the years from literally hundreds of artists. This kind of clip-art tends to be of higher quality than art from smaller companies, but due to the stylistic differences of the many artists, your job of combining images is made more difficult.

Ultimately, you will have to experiment with combining art before you become fully knowledgeable about which styles work together and which do not. We can, however, provide some examples of combinations that we think conflict with each other, and combinations that blend to form seamless illustrations.

2. Do not combine geometric and naturalistic images.



Geometric images and naturalistic drawings look strange together.

The left ghost has been executed in a very geometric style, while the right-hand ghost is naturalistic. Because a viewer will recognize that the two objects are the creations of different artists, they appear awkward when combined into a single illustration.

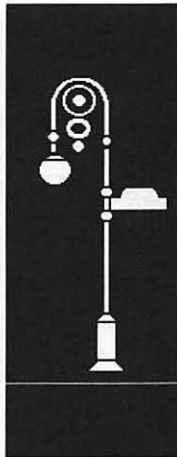

Despite the fact that a lamppost and a castle are very different objects from the ghost, they are represented in a similar geometric style, and give the combined illustration a consistent appearance.

3. Do not combine “heavy” images with delicate line drawings.

*Heavy images
tend to overwhelm
delicate line
drawings.*



The girl on the left is a heavy image, composed of many large black shapes and thick lines. By contrast, the girl on the right is delicate, the result of thin pencil tool strokes. The two appear as two separate objects placed beside each other, rather than blending to form a single illustration.



Only delicate line-drawn images make up this cohesive illustration.

When combining different clip-art images, first determine whether the images share similar styles. Images drawn by the same artist may almost always be combined, but you must experiment with images created by different artists, ultimately judging for yourself whether they produce a harmonious or disparate cumulative effect.

Matching similar styles is only part of the art of combining multiple clip-art images. After you find images that seem to be drawn in similar styles, you must determine how to position the images relative to each other.

Positioning multiple images to interact

Regardless of the stylistic similarities between two images, they will appear awkward next to each other unless they interact. After all, what purpose does a graphic serve if its objects have no obvious relationship to each other?

When considering adding a piece of clip-art to a graphic, make sure that you know and graphically define its purpose. Each image should appear essential to the context of the illustration; none should appear to be “just sitting around.”



After you find images drawn in similar styles, you must determine how to position them relative to each other.

Although these elements have been drawn in an identical style, they seem to have no relationship to each other. No object relates to any other object; they are simply jumbled together like some kind of graphic salad.

Our final method for using clip-art explains how to combine a clip-art image with an original drawing, producing truly customized graphics that only partially incorporate existing artwork.

Inserting clip-art into original drawings

A very complex illustration can rarely be assembled simply by combining existing images. Sometimes, no matter how thoroughly you search your clip-art library, you cannot locate that one object that makes or breaks your graphic. In such a case, you may have to partially draw the graphic on your own and combine it with clip-art to produce a finished piece.

When combining clip-art with your own work, you must take into account the same stylistic considerations we encountered in combining multiple clip-art images. In essence, either the clip-art must match your style or you must match the style of the clip-art.

When combining clip-art with your own work, the clip-art must match your style or you must match the style of the clip-art.

Finding clip-art similar to your personal style

When combining clip-art with your own art, you are always combining the work of two different artists. Hence, there will always be some discrepancy in style. But you can partially match your style by selecting clip-art similar to your own. In Chapter 1, we suggested that you develop your personal style by copying from the work of established artists. If you were forward-thinking enough to consult clip-art when developing your style, then you may be able to combine that clip-art with your own artwork to produce finished illustrations.

However, few of us even considered clip-art when developing a style. After all, clip-art is rarely produced by leading professionals in the art world. Despite clip-art's inestimable utility, consulting clip-art for artistic style is like consulting a discount house for this year's fashion trends. Clip-art is supermarket material, not "high art."

But just as an outfit you find in a department store is often an imitation of a successful fashion designer's work, clip-art often imitates the work of successful commercial artists or commercial art trends. This is because clip-art companies realize that if their graphics look familiar, they will sell better. When looking for clip-art that matches your style, you may therefore find it helpful to keep in mind the artists that you have imitated and keep an eye out for similar imitations in your clip-art library. If a clip-art image borrows from the same artist from whom you borrowed, your graphic and the clip-art will probably work together stylistically.

Look for clip-art that appears to share common stylistic origins with your work.

In these days of Coolidge-like prosperity, you see many clip-art images reminiscent of 1920s poster art. If your personal artistic style is based on this genre of art as well, then this ocean liner could combine well with your work.

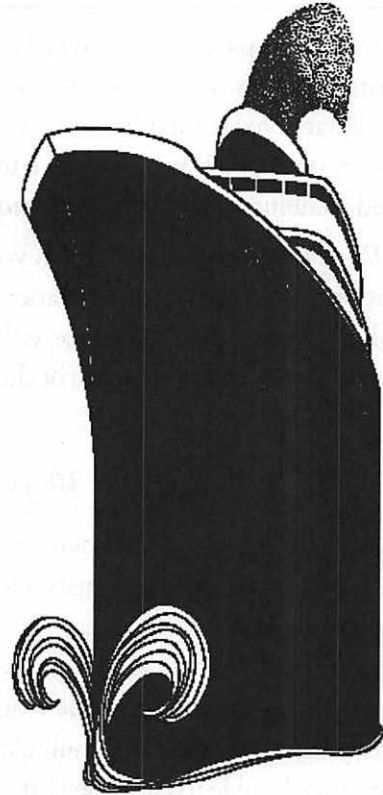

Matching clip-art style to your personal style is one way of combining clip-art with your own work to form a successful finished illustration. Look for artwork that seems to share common stylistic origins with your work.

Another way to combine clip-art with your artwork requires less searching but more flexibility on your part. This method involves selecting any clip-art that suits your conceptual purpose, and modifying your style to match that of the clip-art when filling in missing details.

Modifying your style to match clip-art

Big graphic concepts require numerous graphic elements. Suppose that you want to represent a society party. If you're lucky, you can locate a complete society party graphic from your clip-art library. However, finished multi-object graphics are not very popular clip-art images, since complex drawings inherently have more limited uses. In all probability, you will have to create the drawing from scratch or piece it together using several clip-art images—a few chairs, a table, some musicians, several party guests—tied together with details you fill in from scratch. You are unlikely to find such a variety of clip-art objects that match your personal artistic style; in fact, you will be hard-pressed to locate so many images that do not conflict with each other. But if you are able herd together a generally compatible horde of objects, you will be better off altering your style to match that of the majority.

Matching a foreign style is not as difficult as it may sound. Basically, you must observe the stylistic considerations we discussed in the *Combining multiple clip-art images* section, earlier in this chapter. Are the clip-art images cute or serious? Are they geometric or naturalistic? Are they heavy or delicate line drawings? After you have answered these questions, you can more accurately estimate how to modify your style.

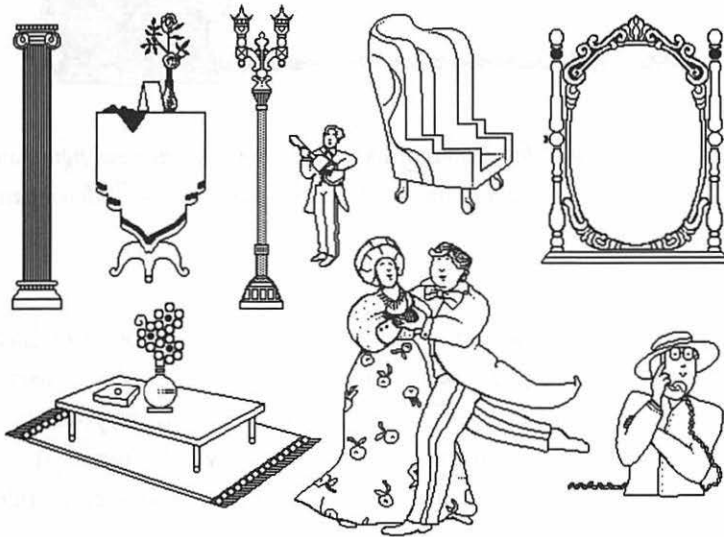

These consistently styled clip-art images could be combined into a party scene.

When assembling a horde of compatible images, you are better off altering your style to match that of the majority.

The final issue regarding combining your drawings with existing art involves clip-art images that are designed to frame graphics or text, rather than to serve as stand-alone illustrations. The following text explains how to use these clip-art borders, specifically in the context of framing your own work.

Framing your work with clip-art

Clip-art borders are becoming increasingly popular. They can be used to add flourish to large book cover text, to enhance advertisements, or to frame original illustrations.

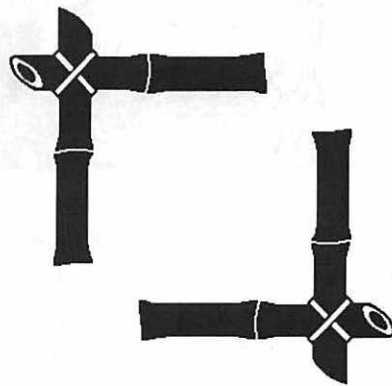

The variety of clip-art borders currently available spans from the ornate to the simple.

Many clip-art vendors sell packages that contain borders exclusively. They are ultimately utilitarian, but when are they necessary? In fact, a typical graphic can stand alone quite adequately without a border. A border around a graphic is exactly like a frame around a painting in a gallery: it is an embellishment that succinctly defines the boundaries of the graphic. You already know where a painting ends simply by looking at it. But if you decide to add a border, based on personal preference, it can help to focus a viewer's attention on your work, separating the graphic from other elements on a page in a crisp, elegant manner.

When selecting a border, consider the character of the graphic it surrounds. A very heavy border can overpower a graphic; a very light border can be overpowered by the graphic.

A heavy border can overpower a graphic; a light border can be overpowered by the graphic.



The illustration on the left has a very ornate border. Although the image is strong and heavy, the border competes with the artwork for viewer attention. On the other hand, the border on the right is too light for such a heavy image. It is so overwhelmed by the illustration that it serves no purpose. Ornate borders are best reserved for large text; light borders are best for framing delicate line drawings.

A heavy border should be used only with large, bold type. It rarely lends itself to any but the most dense graphic elements. A light border should be coupled primarily with medium-weight text or delicate line drawings. Most drawings should receive a border that consists of thick bold lines without exhibiting a conspicuous flamboyancy. A graphic frame should be weighty enough to support an illustration, but not so pompous that it competes for viewer attention.



Consider your border simply another piece of clip-art that must be balanced with your illustration.

This border suits our illustration much better than either of the previous examples. It is heavy enough to support the graphic, yet light enough to focus viewer attention on the graphic, not on itself.

Consider your border simply another piece of clip-art that must be balanced with the rest of your original illustration. The frame should be stylistically compatible with your graphic.

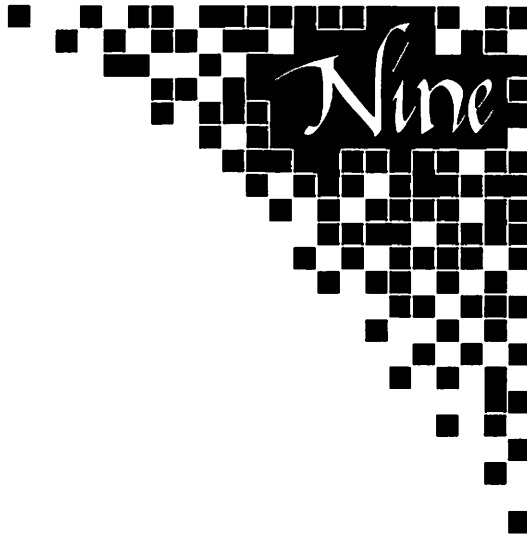

Using Scanned Artwork & Photographs

In the previous chapter, we discussed how you can build an illustration based on clip-art images collected or purchased from other artists. Clip-art provides a fundamental starting point in the graphic process, saving you from the time-consuming task of creating illustrations from scratch.

Sometimes, however, you may want to base a drawing on an image that is not stored on disk, but which exists on paper or as a photograph. In such a case, you may create an electronic scan of the image, a process similar to photography in that you transfer the image from one environment to another. Electronic scans are produced using any of several compatible scanning devices, or scanners.

You may base a drawing on an image that is not stored on disk, but that exists on paper or as a photograph.

Scanners are available in monochrome, gray scale, and full color models, increasing respectively in price.

Some scanners are sheet-fed; others are flat-bed. When operating a sheet-feed scanner, you load the hard copy image—preferably a photocopy rather than original artwork—into the device much as you would load a sheet of paper into a typewriter. The scanner then feeds the page through, scanning the image to disk as the device’s optic sensor sweeps in horizontal passes. When operating a flat-bed scanner, you simply lay the page face down on the device window much as you would when operating a photocopier. The page remains stationary while the optic sensor moves sweep by sweep to record the image.

Scanners are available in monochrome (black and white only), gray scale (recording 16 shades of gray), and full-color models, increasing respectively in price.

A scanner allows you to create electronic copies of original artwork and photographs. You may also scan photographs clipped from magazines or other periodicals, as well as classical artwork, comic strips, maps, charts, and so on. Precaution should be exercised, however, since the copying of published images is often precluded by copyright laws. You are better off scanning only those images which you know to be in the public domain or whose copyrights have expired, or images specifically commissioned by you or your company.

This text is designed to introduce you to the process of scanning. Nevertheless, the purpose of this chapter is not to teach you how to scan. Procedures vary greatly from scanner to scanner; we could fill the pages of another volume with such information. If you own or have access to a scanner, we recommend that you study the user documentation distributed with the product.

The purpose of this chapter is to provide tips regarding the use and manipulation of existing scans using a painting application.

Scan formats and paint application compatibility

Right after you scan an image, it exists in your computer's RAM or in a disk buffer until you save it to disk. Most scanning applications offer several image-saving formats. The format you select when saving determines what paint application can be used to edit the file.

Scanning software typically allow you to save a scanned image as a MacPaint or TIFF (tagged image file format) document. The MacPaint format is very limited: resolution may not exceed 72 dots-per-inch, document size must be eight inches wide by ten inches tall, and only black and white dots are supported. However, almost all paint applications open MacPaint files. On the other hand, TIFF supports multiple resolutions, multiple document sizes, and 16 or more shades of gray. (A color TIFF format also exists, although few scanning applications support it.) But TIFF files cannot be opened by several paint applications (see Chapter 10 for specific software information).

A handful of programs are available to Macintosh users for the sole purpose of editing scanned images. The most popular of these are Image Studio from Letraset USA, and Digital Darkroom from Silicon Beach Software. Both applications support TIFF documents. But since neither is particularly useful for creating original images, they cannot be used as general paint applications. In a sense, paint software is useful because it can be used to create original art *and* to edit scanned images, assuming the latter are saved in compatible formats.

All monochrome paint applications open MacPaint scans and many will open black-and-white TIFF images. However, very few monochrome programs can open a gray scale TIFF image. This is because a gray scale image is composed of dots that are one of 16 shades of gray while a monochrome application only supports black or white dots. Those monochrome applications that do open gray scale TIFF documents must *dither* the gray pixels, expressing them as a pattern of black-and-white pixels to produce a similar visual effect.

A color paint application that supports TIFF documents is generally best for manipulating gray scale scans, because it can accurately express shades of gray on-screen without dithering. But what about when printing? After all, moderately priced laser printers create only black-and-white

Monochrome applications dither the gray pixels in a photographic scan, expressing them as a pattern of black and white pixels.

copies. When a color program prints a gray scale scan (or other art) to a monochrome printer, the printer *halftones* each pixel. Halftoning is a process by which a shade of gray is expressed as a series of tiny round dots. This is the same process used to print photographs in a newspaper.

Color programs halftone gray pixels when printing a photographic scan to a high-quality output device.

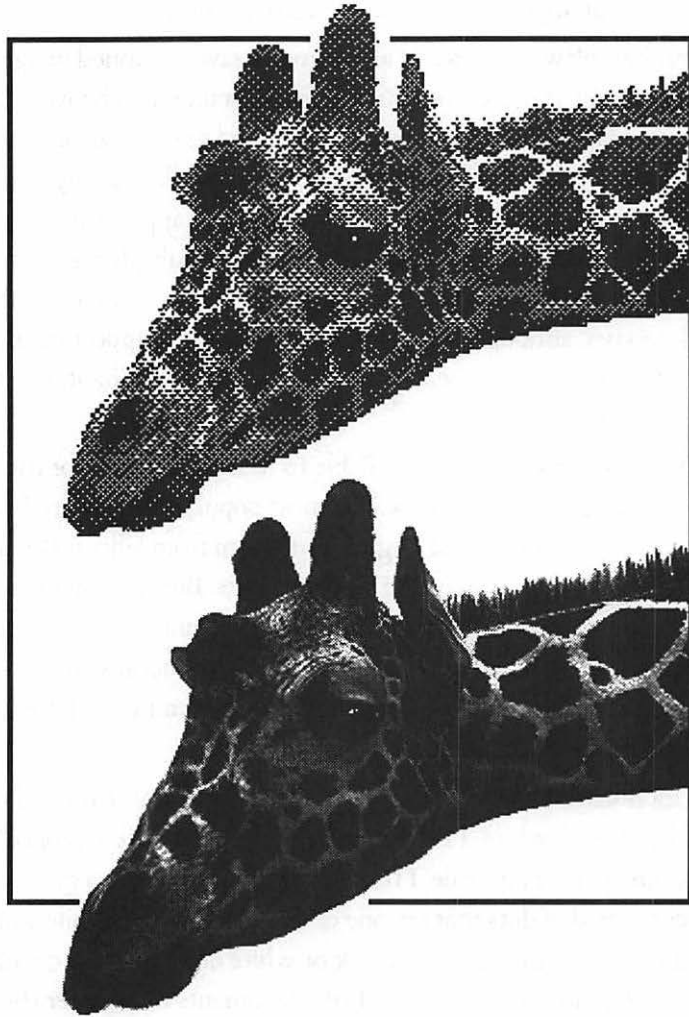

The top scan was saved as a MacPaint file and printed from a monochrome application. Shades of gray are imitated through dithering. The scan on the bottom was saved as a TIFF document and printed from a color paint application. The photo has been halftoned, or expressed as a series of tiny round dots, producing a cleaner effect than dithering.

Basically, dithering and halftoning serve the same purpose—they allow a monochrome device to imitate shades of gray, whether the device is a black-and-white computer screen or a black-and-white laser printer. The primary difference is one of resolution. Standard screen resolution is 72 dots-per-inch, so it must use dithering. Laser printer resolution starts at 300 dots-per-inch, so it can use halftoning.

Ultimately, you will have to become familiar with your specific paint application before you can determine which variety of scans—MacPaint, black-and-white TIFF, or gray scale TIFF—your program will support. Once you determine which format works for you, you can begin editing scanned artwork or photographs to serve your graphic requirements.

Often, you must clean up scanned images to make them presentable to a discriminating audience.

Cleaning up scanned images

Unfortunately, few affordable scanners produce picture-perfect electronic images. Frequently, scans are rough facsimiles, plagued by extraneous pixels and imprecise lines. More often than not, you will have to clean up scanned images to make them fully presentable to a discriminating audience.

In graphic terms, there are two varieties two kinds of scans—artwork images and photographs. Artwork images appear hand-drawn and to some degree stylized—reality subjected to an artist’s interpretation. Photographs are impartial, exacting duplications of reality. This fundamental difference in appearance requires you to manipulate artwork and photographic scans by separate methods.

Refining and enhancing artwork scans

A drawing is a drawing. That is to say, a finished electronic graphic should reflect a successful drawing technique, whether created from scratch using a paint application or drawn on paper and then scanned. Therefore, you must rely on your knowledge of drawing theory and your understanding of software tools when refining a scanned image.

Smooth out jagged edges, make gray values consistent, and eliminate unclear details when refining scanned artwork.

Refining scanned artwork is typically a three-step process:

1. Smooth out rough edges and imprecise lines. Lines in a graphic often take on a jagged appearance when scanned. By smoothing out such jagged lines using the pencil tool in an enlarged view size like “fat-bits,” you improve the quality of your finished image.

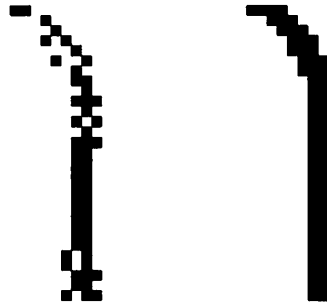

These two examples, enlarged to four times normal size, demonstrate the appearance of a scanned line and the same line cleaned up.

2. Make gray values and patterns consistent. Unfortunately, gray areas of your original artwork are rarely interpreted as homogeneous patterns by a scanning device. Instead, lights and darks are commonly expressed as random pixel collections that may look muddy when opened in paint software. The appearance of these gray areas can be improved by tracing over them with a filled shape tool, such as the polygon or freehand tool.

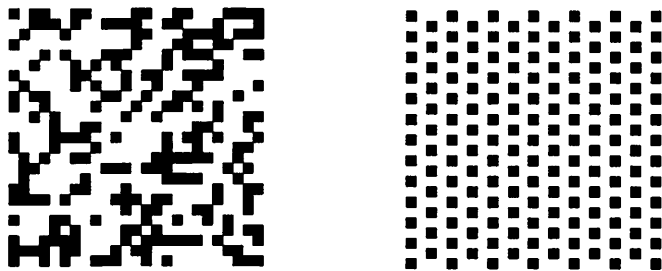

Also enlarged to four times normal size, the first figure demonstrates how a gray area of a graphic might be interpreted by a scanner. The pattern on the right expresses a similar gray value in a more visually pleasing manner.

3. Draw in or erase unclear details. If lines become jagged and gray values are misinterpreted, small or complicated details may be distorted beyond recognition. Other times, a detail is missing altogether from the original artwork. Sometimes it is worth expending extra effort to redraw the detail in by hand,

however, a detail does not contribute enough to the finished piece to make it worth the time required to clean it up, simply erase it from the graphic.



This piece of artwork was electronically scanned and saved as a MacPaint file.



The graphic on the left represents the completed first step in the refinement process. Notice that all rough edges have been smoothed and the lines made precise. In the middle graphic, we have painted in new gray values and patterns using the paintbrush tool, improving the appearance of the background foliage. And in the last graphic, we drew in the missing portion of the woman's left hand and erased the flowers from her dress.

Electronically enhancing scanned artwork is a consistent extension of the traditional graphic process.

Scanned artwork almost always requires clean-up. But beware of graphics that are more trouble than they're worth. After all, if a graphic takes longer to clean up than to draw from scratch, the results are hardly worth the effort. You may have to experiment to learn when scanned artwork should be cleaned up and when an image is so hopeless that it needs to be rescanned.

A drawing is a drawing. Creating a graphic on paper is a very similar process to drawing in a paint application. Electronically enhancing scanned artwork is therefore a consistent extension of the traditional graphic process, making possible successful finished drawings that originate in one environment but conclude in another.

However, a photograph is not a drawing. Enhancing a photographic scan is a tricky process, because you cannot clean up a scan in the same way that the camera shoots the original picture.

Refining and enhancing photographic scans

Like scanned artwork, a photographic scan often requires refinement. There may be stray pixels, fuzzy lines, random dots patterns, and obscure details that make the scan unfit for publication. But in the refinement process, you cannot manually imitate the technique used to create a photograph. A camera exposes film based on a perception of light, while an artist draws lines and shapes based on a perception of form, depth, volume, and so on. The two techniques are not stylistically compatible. Therefore, the more you clean up a photograph using your knowledge of drawing theory, the less like a photo and more like a drawing it becomes. Because drawing theory does not accommodate the photographic process, you should only draw on a scanned photo if you intend to trace over the photo to create a realistic illustration.



Here we have scanned a photograph and saved it as a MacPaint file. The photo displays two prominent politicians. Suppose we want to delete the Senator and embellish the current President only.

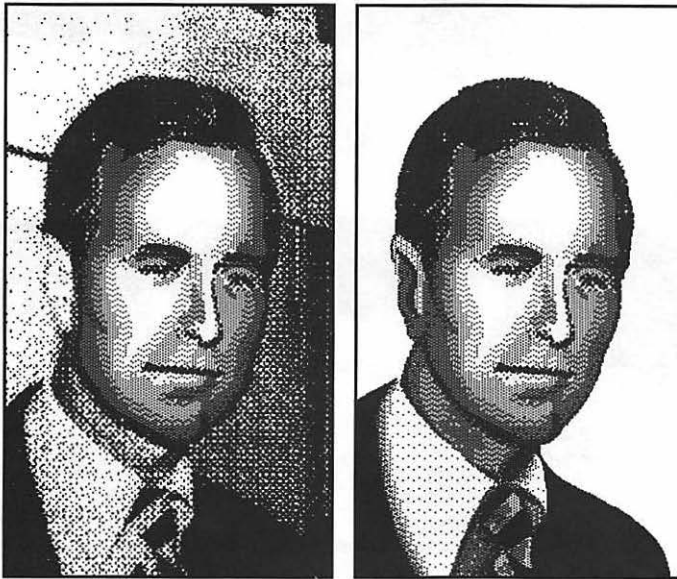

As you clean up a scanned photo, it appears less like a photograph and more like a drawing.

These two examples represent stages in the refinement of our photographic scan using a monochrome painting application. Notice that the more we work on the scan, the less like a photo and the more like a drawing it becomes.

However, you can enhance a scanned photo somewhat without altering its photographic appearance using your understanding of software tools, specifically with transformation commands. Scaling, flipping, and rotating a shape may not refine its appearance, but they also do not deter its photographic quality.

You may use transformation commands to enhance a scanned photo without altering its photographic appearance.

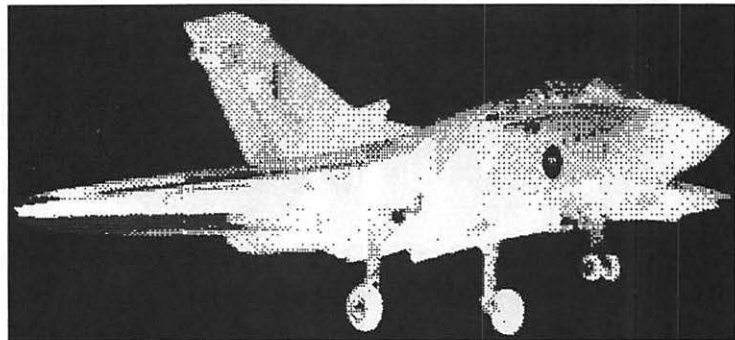
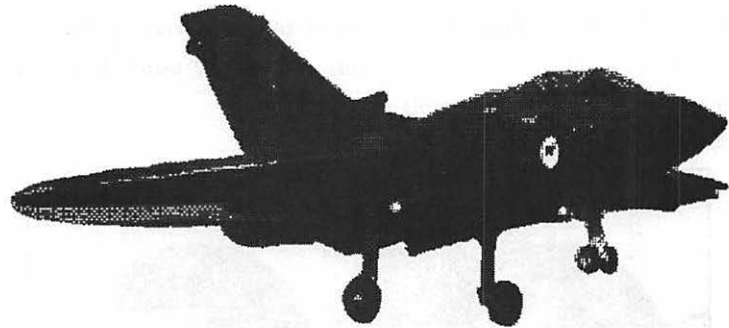
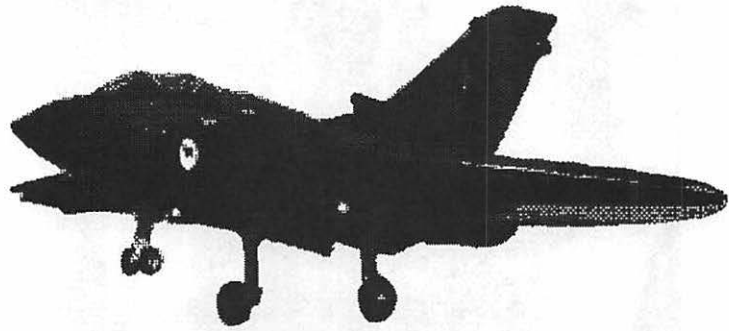

No matter how we transform this scanned fighter plane, it remains fundamentally photographic in appearance.

If you own a color paint application, you may have access to more powerful photo enhancement capabilities than those offered by standard transformation commands. For example, photographic scans often look “computerized,” comprising differently colored pixels that look unnaturally geometric when positioned next to each other, producing an effect much like seeing through a compound eye. To address this problem, some color applications offer a “Blend” command which mixes the colors of adjacent pixels in a selected object. Blending a geometric scan smooths the transitions between light and dark pixels, creating a more natural appearance.



This photographic scan of a political figure was produced by a low-quality scanning device. There is harsh contrast between adjacent pixels, and the scan is generally washed-out.



By adding a darker background and applying the “Blend” command twice, we produce a more natural and recognizable scanned image.

Blending a geometric scan smooths the transitions between light and dark pixels, creating a more natural appearance.

The “Blend” command is only one example of the many special effects features provided by high-end color applications. Because these commands are electronically automated, they are more accurate at duplicating photographic effects than an artist using drawing theory could be.

You may also combine drawing theory with special effects to turn a bland photo into a unique and exciting art/photo hybrid. Paint applications provide one of the few environments where art and photography can be mixed so easily and so successfully.

You may combine drawing with special effects to turn a bland scan into a unique art/photo hybrid.



Even a low-quality image can be enhanced to produce exciting finished artwork using both drawing tools and special effects commands in a paint application. Here we used a color program to combine the appeal of a drawing and the accuracy of a photograph into a single piece of artwork.

Scanned photographs may be the starting points for realistic computer drawings. If you prefer to retain the photographic quality of a scan, you may manipulate it using transformation commands exclusively. Or you may combine methods to create unusual and attractive art/photo hybrids.

Anything that you can open using a paint application—whether original artwork, clip-art, or scanned artwork or photographs—may be refined, enhanced, or simply altered to your specifications. The fact that you

don't always have to start from scratch when creating an illustration is the real beauty of computer graphics. Even people who aren't necessarily interested in drawing can learn to manipulate existing artwork to their satisfaction.

If a scan completely fails to meet your requirements, you may want to consider rescanning it. But keep in mind that many scans appear a little rough in the paint environment regardless of how well you operate your scanning device. You may refine such scans using your knowledge of drawing theory if you want the finished product to look like a drawing. Or you may use special effects to retain a photographic appearance.

Our final chapter reviews every paint application presently available for Macintosh computers. Each review states whether the application opens and saves paint or TIFF format documents, and outlines the special effects features of each program. This information can be very useful when refining and enhancing scanned images.

Part 4

Comprehensive Software Review

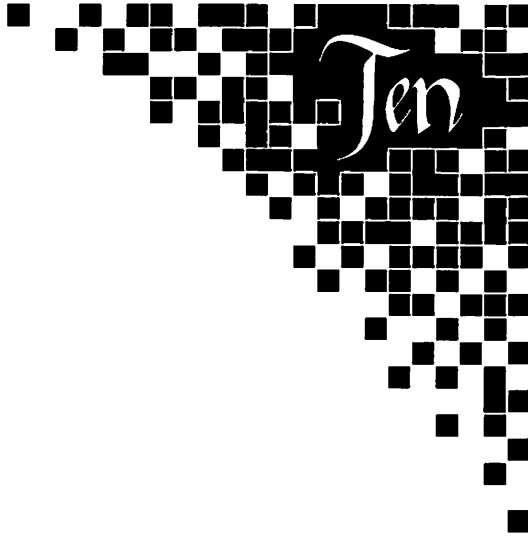

Paint Applications on the Macintosh

In previous chapters, we have discussed how to create both simple and sophisticated illustrations using a generic painting application. In this chapter, we concentrate entirely on individual applications. We review a total of 15 paint programs in alphabetical order, all of which run on the Macintosh computer. Some of them, most notably MacPaint and FullPaint, are straightforward applications, offering no more than one or two commands that have not already been thoroughly covered in this book. Others, such as PixelPaint and Studio/8, offer features well beyond those we have covered, but remain based in the electronic painting tradition. In other words, they offer almost all of the features we have discussed, and the fundamental technique for working in the software is the same as that suggested in this book. So a drawing technique that is successfully applied to MacPaint is also applicable to PixelPaint as well.

At the top outer corner of each page is the icon of the software being reviewed, so that you may easily locate a specific product by flipping through pages. Finally, you may see one or two icons displayed in the margin next to a review:



The “Monochrome” icon indicates that an application can only be used to create black-and-white graphics, even if you own a color monitor.



The “Color” icon indicates that a program supports at least 256 colors or gray tones. Generally, color applications only run on a Mac II with a color monitor.

Normally, only one icon is displayed. If both are displayed, both a monochrome and a color version of the application are available.

Unfamiliar terminology

Throughout this chapter, you may encounter one of three terms that we have not discussed or defined earlier in the book. This is most common in the *Distinguishing features* section, where a product may offer an exceptional tool or command. To avoid confusion, we define these terms now.

Object-oriented graphic: an image that is described as a discrete, mathematical element, similar to those created in MacDraw. Object-oriented graphics may not be edited using common paint tools.

Overlay modes: when one element is drawn in front of another, you may determine whether it is opaque or transparent, or if it performs a special effect such as inverting those elements behind it.

Bezier curves: the curvature of some line segments may be controlled by dragging at a lever connected to the curve at a point specified by the user. The lever is tangential to the curve at this point.

All other terms are simple enough to define on-the-spot, or are covered elsewhere in the book. If you cannot locate a term, consult the index.

The following pages review all paint applications available for the Macintosh in alphabetical order. Scores or ratings are not included.

Distinguishing features (cont.)

- object-oriented (MacDraw-type) graphics capabilities, including bezier curve manipulation
- autotrace paint images with PostScript polygons
- adjustable arrowhead line cap options (see figure)
- create bit-maps with up to 2540 dot-per-inch resolution
- move selected images up, down, left, or right by one pixel using arrow keys (not available on old keyboards); customize distance when also pressing command or option key
- information manager displays exact or relative coordinates of cursor
- assign two colors, foreground and background, per graphic element; combine several paint images for full-colored artwork (see figure)
- 12 pre-defined color palettes
- “Object” command converts object-oriented graphic to paint
- assign images as macro commands (similar to Cricket Paint tools; see next section)
- sophisticated layering features; create, delete, name, display, save, and print specified drawing layers
- select from QuickDraw (standard), wireframe (outline only), and PostScript display modes
- embed pure PostScript routines

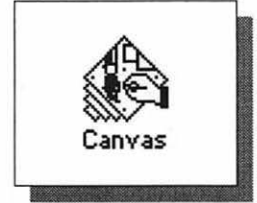

Negative attributes

- Canvas DA lacks some simple features; can't edit patterns, no “Trace edges” command, no custom brush shapes
- cannot edit individual pixels at paint image resolutions higher than 72 dots-per-inch
- spraypaint tool works in solid black only
- only save one selected bit-mapped object at a time as TIFF document; converts image to black-and-white



Who needs Canvas?

Generally, Canvas is a powerful program for combining paint and draw images in a single document. You can define unlimited numbers of drawing layers for placing multiple images in front of and in back of each other, easily producing complicated drawing structures. You may also define macro commands to repeat images you use on a regular basis. The DA is incredibly convenient, but there are trade-offs. First, it lacks several of the features that sets Canvas apart from other paint programs. Second, like any desk accessory, it consumes additional RAM space, which means that you may frequently run out of memory when working on a one-Mbyte computer. But all in all, Canvas and Canvas DA have unique features unavailable in many monochrome competitors, and are thus ideal for the power-user with a small pocketbook.

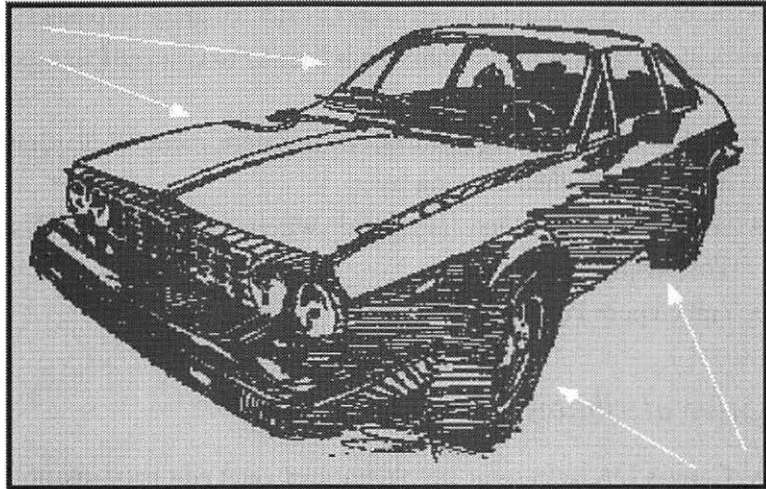

Deneba Software
3305 NW 74th Ave.
Miami, FL
33122
(305) 594-6965
\$299.95 retail
\$125 for DA only

This painting was created in Canvas by combining six separate paint and draw images into one multi-colored illustration. We began by opening a high resolution clip-art TIFF document containing the image of a car. We assigned the car a light gray background and a dark gray foreground. Then we added the arrows, each a separate paint image with the same light gray background as the car and a white foreground. Finally, we drew an object-oriented rectangle around the car, with a black interior and a gray outline.

version reviewed: 2.0

Who needs Cricket Paint?

Cricket Paint is a surprising departure from standard monochrome paint applications, combining the advantages of object-oriented drawing approach with the freedom and inherent simplicity of the painting environment. The only problem is that sometimes the disadvantages of an object-oriented drawing tool predominate. Freehand images are over-simplified, and shapes created with the bezier curve tool cannot be edited to include sharp corners. On the other hand, Cricket Paint allows you to design your own tool to draw unlimited reproductions of almost any image, which is a real time-saver. You can draw a single fish, assign that fish as a tool, and then pass the file to a non-artist to finish the remainder of the school, matching your style fish-for-fish. For users interested in such drawing efficiency, Cricket Paint is a powerful program.

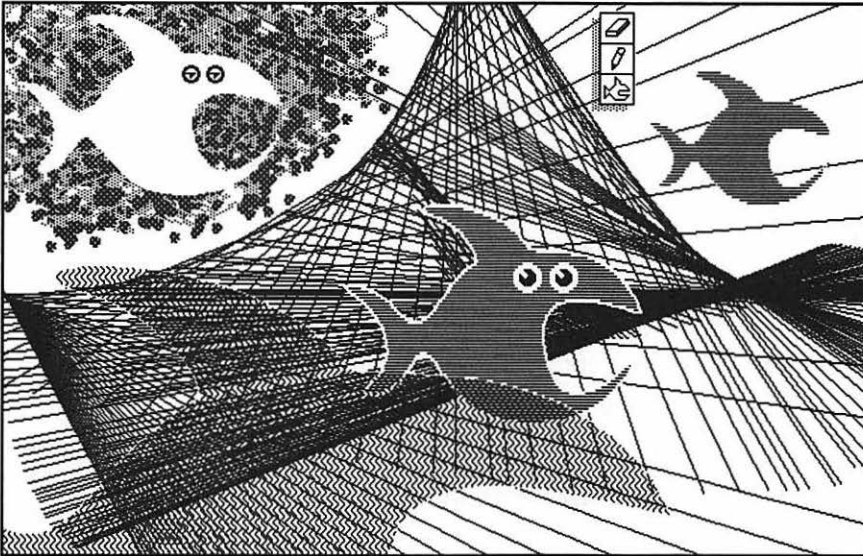
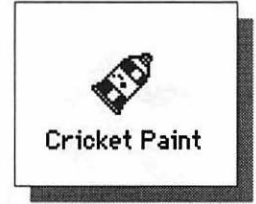

This painting was created in Cricket Paint and saved as a MacPaint file. To create the school of fish, we drew a single fish with the bezier curve tool and assigned the shape to a special fish tool. The other fish were created simply by dragging diagonally with this tool. The fish in the upper left corner was clipped from a background created with the texture tool using the "Stamp object" command. The custom line pattern behind the fish was created with another special Cricket Paint tool called the background tool.

Cricket Software
40 Valley Stream
Pkwy.
Malvern, PA
19355
(215) 251-9890
\$195 retail

version reviewed: 1.0

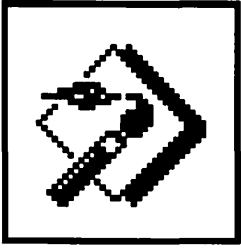

DeskPaint

DeskPaint, like Canvas, is a desk accessory that allows you to open and edit paint files while you're using another piece of software. It comes with an object-oriented graphics editor called DeskDraw. Together, these two DAs must be installed into your System using the Font/DA Mover application, or attached with a mounting utility such as Suitcase or MasterJuggler. After installation, DeskPaint and DeskDraw become accessible as commands under the Apple menu. This makes it possible not only to easily copy and paste graphics into word processing and page layout documents, but also to create or edit graphics to meet on-the-spot requirements.



Hardware requirements

- Mac Plus or SE
- at least one Mbyte of RAM
- 20 Mbyte hard drive

Distinguishing features

- opens MacPaint, PICT, or TIFF files
- saves in MacPaint, PICT, and TIFF formats
- on-line help by double-clicking on unfamiliar tool
- application launches desk accessory independently for large tasks
- set 64 different sizes of paintbrush, spraypaint, and eraser tool
- object-oriented (MacDraw-type) graphics capabilities using separate DeskDraw desk accessory
- browse function displays folder full of MacPaint, PICT, and TIFF files as well as contents of Scrapbook
- standard and advanced transformation functions available as tools after marqueeing an object
- autotrace tool traces paint images with PostScript polygons that may then be pasted into DeskDraw (see figure)



Negative attributes

- cannot create clones by option-dragging selected objects
- autotrace procedure is unnecessarily cumbersome
- DeskDraw refreshes screen slowly with one Mbyte of RAM
- weak documentation



Who needs DeskPaint?

Like all large desk accessories, DeskPaint consumes a good deal of RAM, which means that you may frequently run out of memory when running another application on a one-Mbyte computer. DeskPaint's second problem is its inelegant working environment. Some features don't work quite as you might expect, while others totally malfunction. For example, if you try to open a color file, an alert box will notify you that the operation can't be completed. Subsequently, a blank screen will appear, *with its titlebar bearing the name of the file you tried to open!* If you then create a graphic and save the file, DeskPaint will overwrite the old file without even producing an alert! However, if you're willing to deal with a few quirks, DeskPaint is a convenient and inexpensive painting tool.



The image on the right was created by clicking portions of the painting on the left with the autotrace tool in DeskPaint and pasting each subsequent path into DeskDraw. The result is geometrical and imprecise, but nevertheless quite impressive in the context of a desk accessory.

Zedcor, Inc.
4500 E. Speedway
Suite 22
Tucson, AZ
85712
(602) 881-8101
\$129.95 retail

version reviewed: 2.0

Distinguishing features (cont.)

- “MouseSpot” window breaks down exact and relative coordinates of cursor
- “Mouse crawl” option varies mouse tracking speed by pressing caps lock key; allows for precision movements at normal view size
- comes with LaserPrint, a utility that divides document into four to 16 portions that can be edited separately at resolutions of 150 to 300 dots-per-inch
- also includes ColorPrint, a color coding utility that colorizes paint files and prints separations
- one of the least expensive softwares for the Macintosh



Negative attributes

- only one magnification level (“fat-bits”)
- window size doesn’t account for monitor dimensions
- display incompatible with color monitors

Who needs FullPaint?

Despite the application’s overall lack of features, there are advantages to FullPaint that make it something of a contender these days. For example, it’s incredibly easy to use. There isn’t a single command that isn’t implicitly obvious. And the price is right. After all, when you come right down to it, some of us are exceptionally frugal. We want to do what everyone else is doing, but we’d like to pay about a tenth of the price. If you’re that kind of person, if you can’t quite bear the thought of upgrading from a 512 to a Mac Plus, then FullPaint is your kind of software. It’s cheap, it works on some very old computers, and it’s easy to use. In a sense, that’s what painting is all about.

Ashton-Tate
20101 Hamilton
Ave.
Torrance, CA
90502
(213) 329-8000
\$99.95 retail

version reviewed: 1.1E

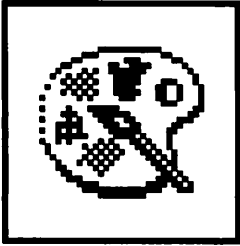

GraphistPaint II

GraphistPaint II is really a combination color paint program/video image editor. It lacks some of the high-end commands and convenience tools offered by such programs as PixelPaint and Studio/8, but it compensates by offering features geared specifically toward photographic halftone editing, such as those offered by Image Studio and Digital Darkroom (neither of which is covered in the scope of this book). This is not to say GraphistPaint II is entirely designed for photo image editing; in fact, it offers two notable features its color paint competitors lacks. First, it allows you to wrap any object around a sphere to produce a convex mirror effect. Second, it permits you to assign any object or existing document as a stencil, which can be pasted in front of or behind the rest of your painting, in a transparent, inverted, or knock-out form. The stencil also exists on its own separate layer, so that the stencil can be “incrusted” or merged into a specified portion of your illustration.



Hardware requirements

- Macintosh II
- at least two Mbytes of RAM
- 8-bit video card with color monitor
- 20 Mbyte hard drive

Optional equipment:

- video frame-grabbing card



Slated for release from Aba Software is a monochrome version of their product called GraphistPaint B&W, designed by the French company Adone Systeme to run on a Mac Plus or SE.



Who needs GraphistPaint II?

GraphistPaint II is one of the few color paint applications geared specifically toward editing color video images. Unfortunately, it is not particularly intuitive. Many standard operations to which you may be accustomed are inoperative or quirky in this application. For example, when you lasso an object, the selection area does not shrink to the size of the object; instead, the background becomes selected as well. But as long as the background is white, you can make it transparent by changing the overlay mode. You cannot press the option key while dragging a selected object to clone it, but you may create multiple copies of an object using the "Paste" command. Although nothing is impossible in GraphistPaint II, you may find that you have to go about things differently than you would expect.

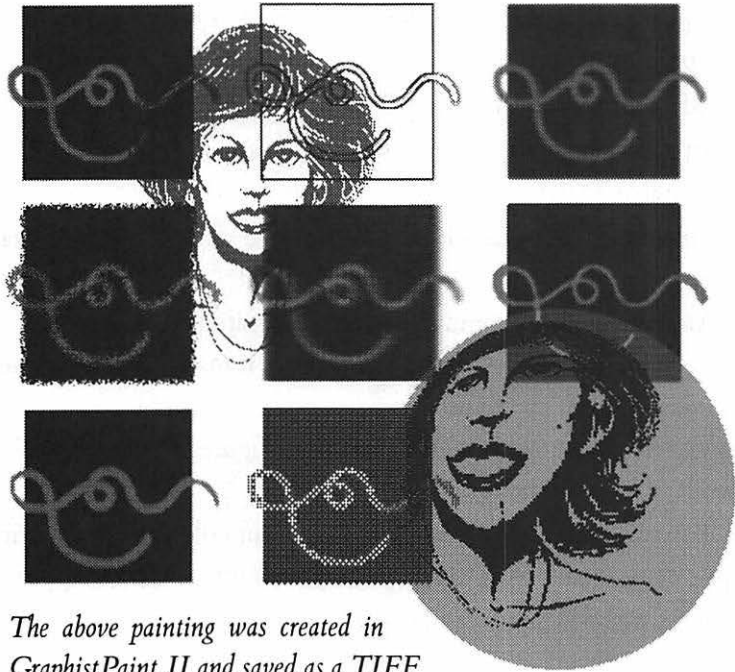

Aba Software Inc.

OUT OF BUSINESS
Distribution rights to GraphistPaint II have been transferred to ProGraphics, a new company whose address and phone were not available at publication.

\$495 retail

version reviewed: 1.0

The above painting was created in GraphistPaint II and saved as a TIFF file. We first created the object in the upper left corner by drawing a line with the anti-alias brush tool over a gray square. We then made several copies of the object, to which we individually applied one of the following special effects operations (starting at the second object in the first row): contour outline, smooth, diffuse, blur, thicken, thin, and dither. We then imported the image of a woman as a transparent stencil and as a semi-transparent speckled ball.

HyperCard

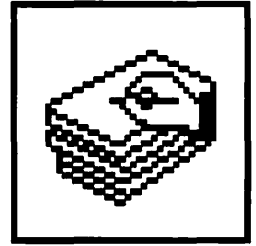

We include HyperCard, knowing full well that it is not intended as a paint or even a graphics application. Instead, HyperCard is a custom software-authoring application, used to create small-format, personal organization documents—called stacks—such as electronic rolodex files, card catalogs, product announcements, and so on. However, it has a graphic interface, similar in detail to MacPaint. This is not surprising, since HyperCard and the original MacPaint share the same primary author, Bill Atkinson, who also designed the Mac's QuickDraw on-screen imaging system. HyperCard's array of paint features in many ways surpasses MacPaint's capabilities. You may import graphics saved in the MacPaint format into any HyperCard stack. You may even export graphics to be edited using almost any paint application.

Hardware requirements

- Mac Plus or SE
- dual 800 Kbyte disk drives



Distinguishing features

- imports MacPaint files
- exports in MacPaint format
- comprehensive help stacks
- select last shape created automatically
- command-click with lasso tool to select entire continuous object
- lighten and darken selected images
- lassoed objects may be transformed; marquee objects may be either transparent or opaque
- pickup feature selects area behind most recently-created shape

LaserPaint Color II

LaserPaint Color II may well be the most advanced graphics application available for the Macintosh. It may also be the most complicated, the most frustrating, and the most difficult to use. One has to expect some kind of trade-off for such high-end features as PostScript path manipulation, text on a curve, almost universal scanner support, and gamma correction for video output in a program that also offers progressive paint operations. Unfortunately, in the case of LaserPaint, the cost in time and sheer aggravation is astronomical. The program is surprisingly slow, and it is not uncommon for the on-screen version of a graphic to differ dramatically from the printed output. These problems, combined with a seemingly endless list of capabilities, make LaserPaint a very bewildering prospect all around.



Hardware requirements

- Macintosh II
- at least two Mbytes of RAM (at about five Mbytes, the program seems to run at a reasonable speed)
- 8-bit or 24-bit video card with color monitor
- 20 Mbyte hard drive

Optional equipment:

- gray scale, color, or 35-mm slide scanner
- laser printer or PostScript-equipped photo imagesetter

LaserWare Inc. also offers a monochrome version of its product called simply LaserPaint, designed to run on a Mac Plus or SE.



Monochrome



Distinguishing features

- opens MacPaint, PICT, EPS, or TIFF files
- saves in MacPaint, PICT, EPS, TIFF, and ASCII PostScript formats
- on-line help by clicking on unfamiliar tool with special cursor
- free, competent tech support
- supports most scanners, 8-bit and 24-bit monitors
- Pantone color matching system compatibility
- editable tool icons
- create bit-maps with up to 600 dot-per-inch resolution
- set size and flow of paint and airbrush (similar to spraypaint tool); paintbrush will actually run out of paint as you draw
- “spatter cap” airbrush option creates variably sized dots (see figure)
- object-oriented (MacDraw-type) graphics capabilities, including bezier curve manipulation
- advanced array of text effects: precision leading (line spacing) and kerning (letter spacing), 11 kinds of shadows, text on a curve
- seven pre-defined color palettes
- easy color pick-up; match surrounding colors quickly with any tool
- mask bit-mapped images with PostScript paths (see figure)
- any gray value pattern can be specified to print as halftone
- when pasting image created using different color palette, existing palette is not affected; two bit-mapped images using different palettes can temporarily exist within same file!
- four-color separation with customizable registration marks
- comes with sample art and full-color photographic scans (see figure)

Negative attributes

- copy-protected (unprotected version \$25 to registered users)
- idiosyncratic working environment
- screen refreshes very slowly with two Mbytes of RAM
- color control is unnecessarily complicated
- “Undo” command often inoperative without warning
- weak documentation

Who needs LaserPaint Color II?

LaserPaint Color II has been designed specifically for power-users. These are people who understand Macintoshes very well, create sizable quantities of printed or electronic media, and own or have access to expensive scanning, video, and printing equipment. You also have to be willing to spend a large amount of time learning and working in this very complicated and strange environment. No tool resembles or works like any tool found in MacPaint, or any other Macintosh application. But if you need a powerful program and you're willing to learn it intimately, LaserPaint Color II could be a wise long-term investment.



This painting, created in LaserPaint Color II and saved as a TIFF file, features a high-quality photographic scan supplied with the application. We masked the scan with a circular shape, an operation that produces the same effect as the cookie-cutter method from Chapter 4. We also filled the top portion of the mask with a "spatter cap" airbrush motif.

LaserWare Inc.
P.O. Box 668
San Rafael, CA
94915
(415) 453-9500
\$595 retail
\$495 monochrome

version reviewed: 1.9.4

Distinguishing features (cont.)

- “Take snapshot” command stores selected area of graphic in RAM; revert to snapshot if you don’t like your changes
- press command with eraser tool to revert erased areas to last snapshot or save
- transparent, reverse, and erase overlay modes
- mouse position window shows exact and relative coordinates of cursor; a feature lifted directly from FullPaint



Negative attributes

- MacPaint format limited to vertically-oriented 8-by-10 inch page
- no advanced transformation commands
- no type size over 48-point; primitive text editing features

Who needs MacPaint?

The best and the worst aspect of MacPaint is its saving format. On the negative end, you’re tied to an eight-by-ten inch page size that doesn’t support colors and has a limited resolution of 72 dots-per-inch. On the good side, almost every application on the Macintosh supports MacPaint documents. You can use MacPaint art in most word processing and page composition programs. Cut and paste desk accessories, like ArtGrabber and Art RoundUp, support this format exclusively. MacPaint files are the only kind of graphics that can be used in HyperCard stacks. Illustration applications such as Adobe Illustrator and Aldus FreeHand can import MacPaint files as tracing templates. Even screen shots, accessed by pressing shift-command-3, are saved as MacPaint. And, of course, all other paint applications can open and save MacPaint documents. So if your needs are basic, if you like drawing intuitively, if you want to integrate your illustrations with other applications, then MacPaint is ideal.

Claris Corp.
440 Clyde Ave.
Mtn. View, CA
94043
(213) 329-8000
\$125 retail

version reviewed: 2.0

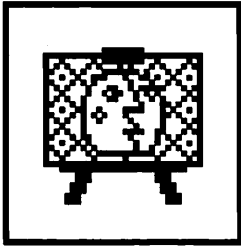

Modern Artist

In a sense, Modern Artist is the gateway to the world of high-end color painting applications for the Macintosh. In terms of features, it is the most stripped down of its competitors. It has little of the flash of PixelPaint or the muscle of LaserPaint, but it does have qualities many of its competitors have missed—an elegantly simple interface and thorough documentation. There seems to be a real effort on the part of Computer Friends, developers of Modern Artist, to create advanced software while remaining down-to-earth. Rather than aiming at users with every piece of the most state-of-the-art equipment, Modern Artist concentrates on the rest of us. Although a Mac II is required, the same application can run on a low-memory system that can only display four gray values or with an 8-bit video card driving 256 colors. There are various disadvantages to working on a low-end system, including a greatly reduced maximum window size, but at least the possibility is there for the intermediate user who is tired of the same old black-and-white.



Color

Hardware requirements

- Macintosh II
- at least one Mbyte of RAM (two Mbytes is recommended)
- gray scale or color monitor
- dual 800 Kbyte disk drives

Distinguishing features

- opens MacPaint, PICT, or EPS files
- saves in MacPaint, PICT, and rPIC formats; rPIC is a special expert saving mode that stores the color palette in a resource file
- on-line help by clicking on unfamiliar tool with special cursor
- configures lasso tool to select objects four different ways
- each tool can be set to a different color
- load and save libraries of mutli-colored brush shapes

Distinguishing features (cont.)

- “Wet canvas” command allows smearing of paintbrush color with existing colors on page (see figure)
- stain tool changes all select items of a specified color to a new color
- spraypaint tool can be set to paint with two colors simultaneously (see figure)
- paint bucket can be configured to fill multiple colored areas (such as gradations) at once
- load and save custom color palettes
- expert mode allows user to define four gradation cycles of 32 colors each, in addition to 92 colors of standard palette
- transformation features include free rotate and rotate by specified degrees, slant, and distort
- create tinted circles and squares using sunglasses tool (see figure)
- draw freehand and plotted; application automatically smooths out lines drawn with the caps lock key pressed
- determines location of light source for images created with shade and 3-D tools using “Illumination” command (see figure)
- when pasting image created using different color palette, existing palette is not affected; the colors of pasted image are remapped
- comes with four disks of sample art
- also includes ColorSep, a utility that prints three- and four-color separations of PICT and rPIC illustrations
- manual contains comprehensive color theory discussion

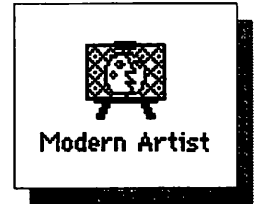

Negative attributes

- rPIC saving format is incompatible with other software
- does not support TIFF format
- only one pre-defined color palette
- most of sample art is copyrighted, prohibiting modification



Who needs Modern Artist?

Although Modern Artist is not the most advanced color painting application, it contains all the tools and features many users will ever need to create full-color computer graphics. Its greatest plus is its ease of use. There are very few unfamiliar tools, and once you learn them, you quickly discover that the rest of the operating environment is so consistent that it takes very little experimenting to master the transition from monochrome to color. In short, Modern Artist is for the moderate user who wants color at a reasonable price, and doesn't want to spend a lot of time learning a new application.

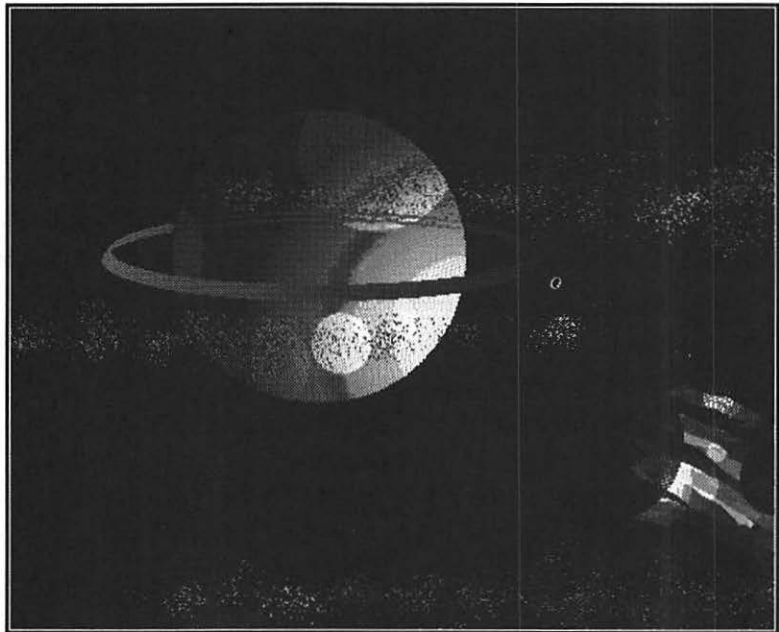

Computer Friends
14250 NW
Science Park Dr.
Portland, OR
97229
(503) 626-2291
\$495 retail

The above painting was created in Modern Artist 2.0. The planet shape was created using the 3-D circle tool, with the light source set near the bottom right corner of the screen. The surrounding circles were created with the sunglasses tool, tinting an area of the graphic darker or lighter depending on the selected color. A dual-color spraypaint tool was used to draw the mists of celestial debris. Finally, the "Wet canvas" feature caused the smeared paint effect in the lower portion of the illustration.

version reviewed: 2.0

NuPaint



NuEquation, developers of NuPaint, have created an application that is both friendly and fun. Like many programs, NuPaint displays a dialog requesting your name, company, and serial number when you first launch it. But whereas most applications offer no escape aside from entering a valid serial number or rebooting your machine, NuPaint provides both a “Cancel” and a “Demo” button, the latter of which allows you to try out the application even if you own an unauthorized copy. Not having fun yet? Then choose “About NuPaint” from the Apple menu and watch the limitless animation routine, featuring the product’s logo and a tiny dancing woman. The woman also appears when you wait for a command to execute, replacing the standard watch icon. Any more and it’d be *too* amusing.

Hardware requirements

- 512K Mac or larger
- single 800 Kbyte disk drive



Distinguishing features

- opens MacPaint, PICT, and Startup Screen files
- saves in MacPaint, PICT, and Startup Screen formats
- on-line help and shortcuts screens
- pencil tool lets you know if you are deleting dots by flipping
- masking tape tool isolates area to spraypaint
- razor tool shaves off dots; trowel tool smooths out lines and repairs broken lines; both offer adjustable blade effects
- smear on-screen images with mixing bowl tool
- create bit-maps with up to 300 dot-per-inch resolution
- repeat images at specified regular intervals (see figure)
- pattern sizes can be 8 by 8, 16 by 16, or 32 by 32 pixels! (see figure)
- full range of 64 related gray values
- automatically create custom shadow of selected object (see figure)

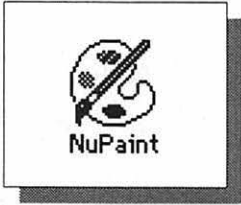

Negative attributes

- primitive text editing features
- creating high-res art involves cumbersome save and print routine
- monitor must be configured black-and-white

Who needs NuPaint?

NuPaint is fun and friendly, offering numerous features not offered by its monochrome competitors. It is also a thoughtful program. If you find that you sometimes have to squint to see on-screen icons, you may enlarge the display size of the toolbox. And because it normally takes more than one application to create a document, you may launch an application directly by choosing the “Transfer” command, thus saving time by eliminating the necessity of returning to the Finder. The razor and trowel tools also save time, performing functions that normally require meticulous editing in “fat-bits.” If fun and friendly is what you’re after, NuPaint will work for you.

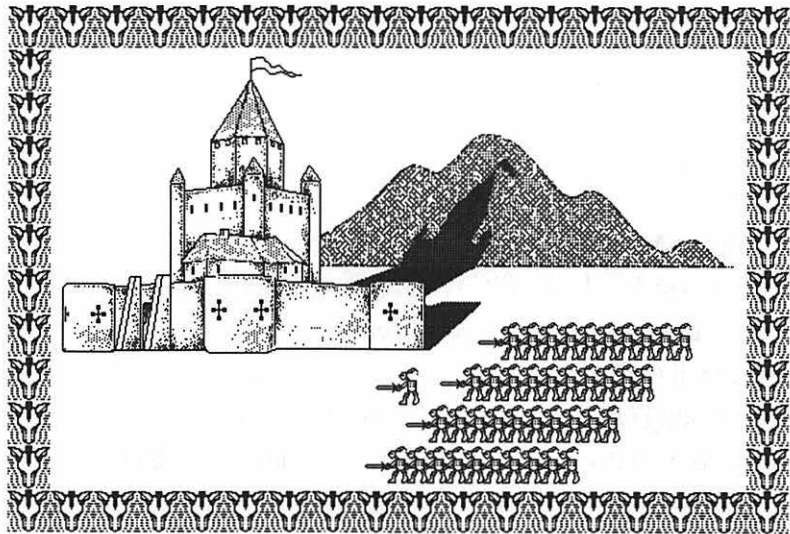

NuEquation, Inc.
1701 N. Greenville
Ave., Suite 703
Richardson, TX
75081
(214) 699-7477
\$139.95 retail

version reviewed: 1.0.3

The above painting was created in NuPaint and saved as a MacPaint file. Notice that the shadow of the castle accounts for the landscape by bending at the mountains. This was accomplished by applying the “Shadow” command to the upper and lower portions of the castle separately. The rows of knights were created using NuPaint’s regular repetition feature. And the border is composed of four rectangles filled with a 32-by-32 pixel pattern.

Photon Paint

Photon Paint, possibly more than any other paint application for the Mac, is a special effects program. Several astounding transformation commands are available in both the color and monochrome version of the program. For example, you may mold any selected object—as if it were a sheet of wrapping paper—around a custom three-dimensional shape, including a cube, cone, cylinder, sphere, or freehand drawing. Photon Paint also allows you to illuminate this shape by specifying the position of a standard flood light or a pinpoint-beam spotlight. The effects are spectacular and entirely automated. However, a program that draws for you is a program that makes you wait. Some of the more mathematically complicated transformations, like wrapping a large colored object around a cube, can take as long as five minutes to complete! If you're unhappy with the effect, you have to choose "Undo" and try it again. You must be very patient to get the hang of the powerful features offered by this program.

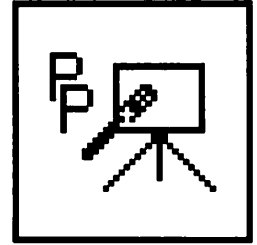

Hardware requirements

- Macintosh II
- at least one Mbyte of RAM (two Mbytes is recommended)
- gray scale or color monitor
- dual 800 Kbyte disk drives

Photon Paint comes with a monochrome version of the product called B/W Photon Paint, designed to run on a Mac Plus or SE.



Color



Monochrome

Distinguishing features

- opens PICT files
- saves in PICT format
- "Pixelize" command sections selected graphic into series of n by n pixel squares, where n is defined by choosing "Set pixelization"

Who needs Photon Paint?

Photon Paint sports many unfamiliar tools and lacks some of the most familiar, utilitarian tools offered by a basic application like MacPaint. There is no eraser, no pencil, no grabber hand, and no substitutes for these tools. In a sense, the program has sacrificed ease of drawing for special effects. In its defense, the effects—including automatic highlighting, automatic shading, and automatic surface mapping—are truly amazing features, once associated solely with dedicated mainframes. B/W Photon Paint offers many of these features in a monochrome format. In addition, Photon Paint is by far the least expensive true color paint application available on the Macintosh, making it, if not ideal, at least extremely useful for the power-user on a budget.

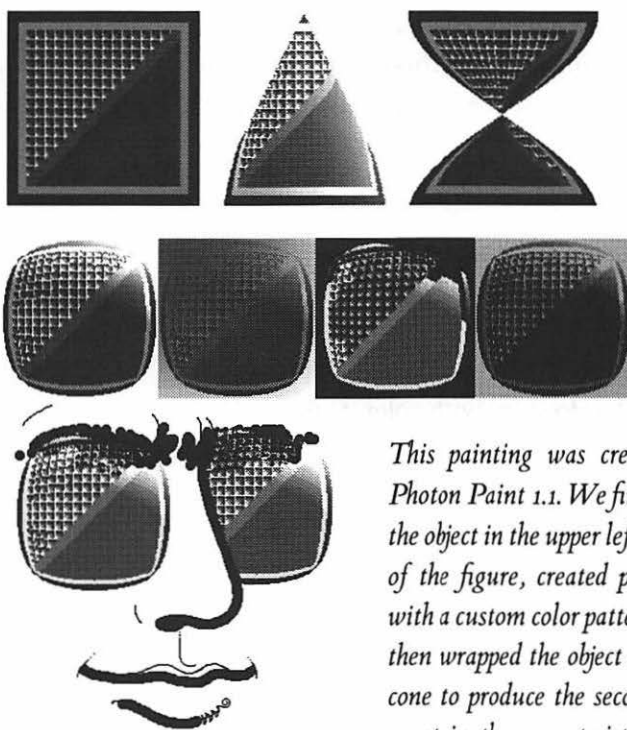
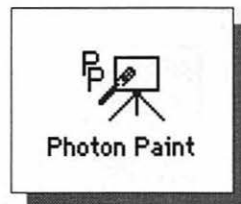

This painting was created in Photon Paint 1.1. We first drew the object in the upper left corner of the figure, created partially with a custom color pattern. We then wrapped the object about a cone to produce the second element in the row; twisted it to produce the third; and wrapped it about a sphere to create the eyeglass lens shape. The cone and the sphere were subjected to a soft light emitting from the upper right corner. The last three elements in the second row demonstrate the various transparency features of the application.

This painting was created in Photon Paint 1.1. We first drew the object in the upper left corner of the figure, created partially with a custom color pattern. We then wrapped the object about a cone to produce the second element in the row; twisted it to produce the third; and wrapped it about a sphere to create the eyeglass lens shape. The cone and the sphere were subjected to a soft light emitting from the upper right corner. The last three elements in the second row demonstrate the various transparency features of the application.

MicroIllusions
17408 Chatsworth
Granada Hills, CA
91344
(818) 360-3715
\$299.95 retail

version reviewed: 1.1

Distinguishing features

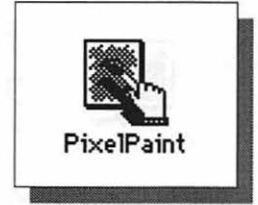

- opens MacPaint, PICT, EPS, TIFF, or Startup Screen files
- saves in MacPaint, PICT, EPS, TIFF, and Startup Screen formats
- Pantone color matching system compatibility
- custom document sizes
- command-click with lasso tool to select entire area with single color; shift-command-click to add colored areas
- blur, smooth, sharpen, lighten, darken, mosaic, or wash selected colors; “Mosaic” command sections selected graphic into series of four-by-four pixel squares (see figure)
- may also apply contour, diffuse, dither, etch, or relief effects to selected image (see figure)
- array of special effects commands specifically applicable to each tool
- 18 pre-defined color palettes
- color quick edit dialog allows for minor adjustments
- gradations are defined as series between currently selected foreground and blend colors, thus including multiple hues
- fully editable gradation and Clipboard image fill effects
- transformation features include free rotate, slant, distort, perspective, arch, double arch, and balloon (see figure)
- customizable shadow effects (see figure)
- create multiple color patterns called tiles; range from 16 by 16 to 128 by 128 pixels (see figure)
- mask images by selection or by color
- when pasting image created using different color palette, existing palette is not affected; the colors of pasted image are remapped
- four-color separation with true pre-press control over screen density, screen angle, and ink build-up
- comes with sample art library and Pantone color formula guide!

Negative attributes

- masking configuration is not saved with document
- lacks auto-scrolling; can only select and draw within screen size

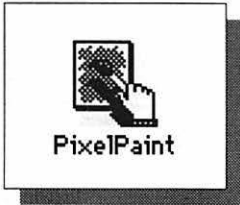

Who needs PixelPaint?

PixelPaint is an extremely powerful and elegant program for creating color images using a Macintosh II. Unlike its powerful rival LaserPaint, it has no object-oriented capabilities; all images are bit-mapped. Yet PixelPaint provides more special painting effects features and greater color control than any of its competitors. If there is anything wrong with the program, it is that it is often difficult to select an image from a complex background, making editing more time-consuming than it might be in an application like Studio/8, which provides a variety of selection modifiers. Nonetheless, PixelPaint is arguably the strongest paint program for the Macintosh, virtually limitless in its graphic potential.

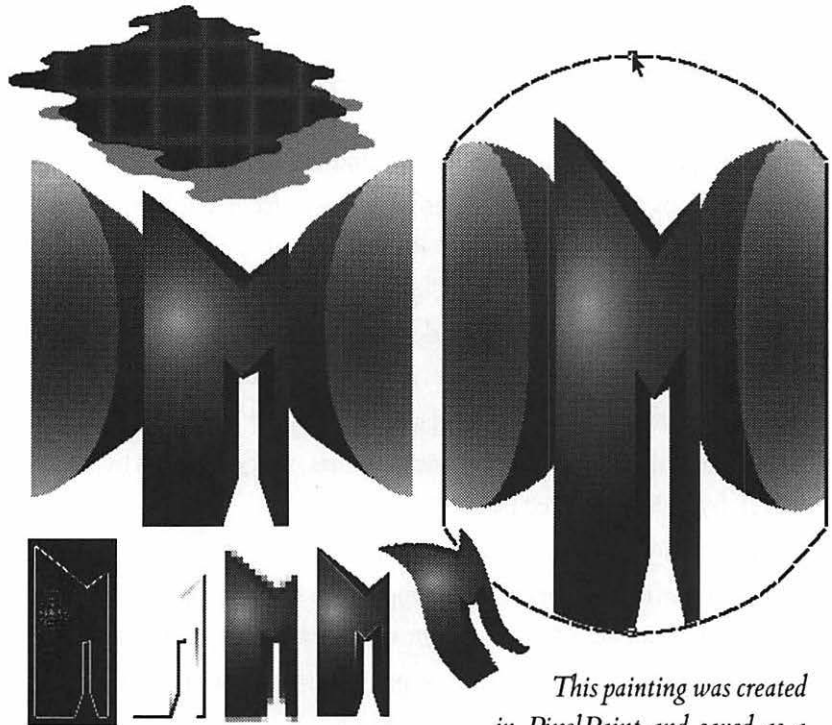

SuperMac Software
295 Bernardo Ave.
Mtn. View, CA
94043
(415) 964-8884
\$595 retail

version reviewed: 2.0

This painting was created in PixelPaint and saved as a TIFF file. We began by creating the stylized, gradated initials on the left. We then cloned them and applied the "Balloon" command to arrive at the image on the right. The cloud in the upper left corner is filled with a 64-by-64 pixel tile pattern and supported by a drop shadow. The "M"s at the bottom of the figure have been subjected to (from left to right) the etch, relief, mosaic, sharpen, and warp effects, respectively.

Studio/8

Studio/8, named for the 8-bit video card required to run the application, is another high-end color painting software, similar to PixelPaint or Modern Artist. In some respects, it is more utilitarian than its competitors. Not only are most of its tools familiar to any MacPaint user, but tools may be modified using a series of nine pull-down menus, each of which is conveniently accessible from the keypad, *even while using the tool!* In addition, Studio/8 is surprisingly fast. The screen scrolls quickly and you rarely have to wait on seemingly simple operations. Finally, Studio/8 comes with a slide show utility called Gallery, useful for displaying your color paintings on-screen in a presentational format. If all of this sounds pretty amazing, it might be because Electronic Arts, the developer of Studio/8, holds one of the longest track records in the personal graphics software business, having previously created Deluxe Paint II for the IBM PC, Commodore Amiga, and Apple IIGS computers.

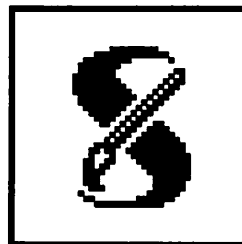

Hardware requirements

- Macintosh II
- at least two Mbytes of RAM
- 8-bit video card with color monitor
- 20 Mbyte hard drive with two Mbytes free space

Optional equipment:

- color thermal printer or film recorder

Slated for release from Electronic Arts is a monochrome version of their product called Studio/1, designed to run on a Mac Plus or SE. Plans are also under way for Studio/32, a more advanced application designed specifically for more powerful color monitors with 24-bit and 32-bit video cards.





Distinguishing features

- opens MacPaint, PICT, or TIFF files
- saves in PICT and TIFF formats
- on-line detailed help dialog with scrolling list of commands and tools
- advanced selection tool options; 36 ways to select an object in all
- blend, smooth, lighten, darken, or tint selected colors
- a second pencil tool mode exposes colors covered by current color
- load any selected image as a paintbrush (see figure); application comes with several multi-colored sample brushes
- customizable airbrush (similar to spraypaint tool) with testing area inside dialog
- bezier curve tool creates freehand shapes that may be edited immediately after creation; pressing control key produces scissors tool, used to divide single line in two
- four pre-defined color palettes
- small on-screen palette remembers last 16 colors used
- create library of eight gradations of up to 32 colors each (see figure); allow filling, painting, and airbrushing in multiple colors
- transformation features include free rotate and rotate by specified degrees, shear (same as slant), distort, and bend (see figure)
- create perspective grid of selected object (see figure); grid can be altered using highly sophisticated x, y, and z-axis modifiers
- mask images by selection or by color
- when pasting image created using different color palette, existing palette is not affected; the colors of pasted image are remapped
- comes with large-sized screen fonts (see figure) and sample art library

Negative attributes

- auto-scrolling is generally inoperative, being limited by the size of the “work area,” the amount of the document that RAM allows to be displayed on-screen
- prints only composites; lacks color separation feature

Who needs Studio/8?

Studio/8 is one of those unique programs that meets almost every graphic demand you can contrive. It's fast, friendly, and elegant, yet remarkably simple in design. If you're looking for a wide variety of special effects, or if you want an application that draws pictures for you, then Studio/8 might disappoint you. But what it lacks in flash it makes up in dependability. It is a hard-working, advanced artist's tool. Its biggest drawback is that it does not print color separations, which means you need a color laser printer or a color slide recorder to get high-quality output. However, if you own either of these devices or if you're simply interested in producing high-quality on-screen images, then Studio/8 is a very satisfactory choice.

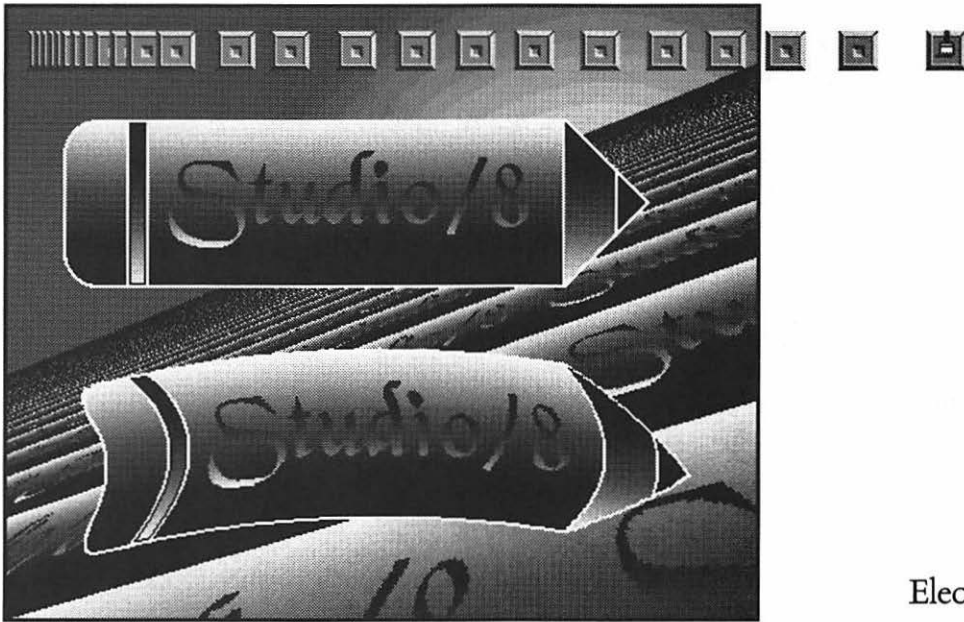

This painting was created in Studio/8 and saved as a TIFF file. The type was created in 48-point Black Knight, one of the large-screen fonts included with the application. The pencils demonstrate the gradation and bending capabilities. Notice we have also painted along the top of the graphic with a custom brush. The most amazing feature, however, is the great field of repeated images in the background, created in perspective automatically using Studio/8's "Fill perspective plane" command.

Electronic Arts
1820 Gateway Dr.
San Mateo, CA
94404
(415) 571-7171
\$495 retail

version reviewed: 1.0

Distinguishing features (cont.)

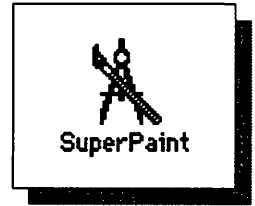

- four marquee tools—rectangle (standard), oval, polygon, and freehand
- set size, flow, and shading attributes of airbrush (similar to spraypaint tool); standard spraypaint also included as plug-in tool
- multigon tool creates specified equilateral polygons
- object-oriented (MacDraw-type) graphics capabilities, including bezier curve manipulation
- precise autotracing features
- adjustable arrowhead line cap and dashed line options
- advanced brush mirror control
- “SuperBits” feature allows bit-maps with up to 300 dot-per-inch resolution to be created in draw layer
- move selected images up, down, left, or right by one pixel using arrow keys (not available on old keyboards)
- coordinates window displays exact and relative position of cursor
- over 30 plug-in tools, the effects of which may be modified by selecting line weights, pressing shift and options keys, double-clicking tool icons, and so on (see figure)
- plug-in commands include blend (same as gradation, see figure), diffuse, lighten, darken, and pickup
- comes with sample art library

Negative attributes

- does not support TIFF format
- cannot set origin of brush mirrors
- pressing command key does not shrink oval, polygon, or freehand marquee to smallest shape that will hold selected image
- only advanced users can create or customize plug-ins; requires substantial knowledge of Apple’s ResEdit utility (see figure)



Who needs SuperPaint?

Since its inception, SuperPaint has been one of the most highly regarded monochrome paint applications for the Macintosh. Newly armed with plug-in tools and advanced autotracing control, the application remains a rugged contender. Our only disappointment in the program is that users cannot *easily* define their own plug-ins. Advanced users may manipulate existing plug-in tools using ResEdit, as we have done below, but the process is complicated and time-consuming, hardly worth the effort if you only plan to use a tool in one or two illustrations. However, plug-ins produce more diverse effects than are possible using a custom tool created in Cricket Draw or Canvas. And providing there is enough third-party interest, there may one day be more plug-ins available for SuperPaint than any other application could hope to emulate.

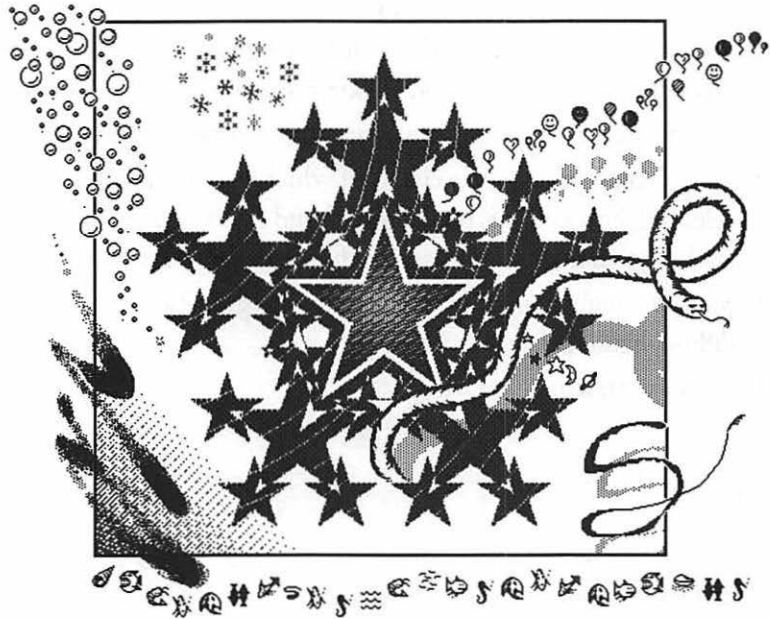

Silicon Beach
Software
9770 Carroll Center
Rd., Suite J
San Diego, CA
92126
(619) 695-6956
\$199 retail

version reviewed: 2.0

The above painting was created in SuperPaint and saved as a MacPaint file. We created each object in the graphic using a plug-in tool provided with the application. For example, the central star pattern was created with a single drag of the allGON tool, which allows you to specify virtually infinite shape-on-shape-on-shape patterns. The row of objects at the bottom of the graphic were created with the sea life tool, a plug-in we customized using Apple's ResEdit.

Appendices



Clip-Art Listing

Many graphics in this book are clip-art images. The following list itemizes each page number that contains a clip-art image, a description of the image, and the clip-art package from which the image originates. A second list includes specific vendor information for each clip-art package.

Note that most clip-art images in this book have been modified to some extent or another. Do not expect a purchased clip-art image to exactly match one of our figures.

Page numbers that are not listed contain original artwork created by the author.

Pages featuring clip-art images

<i>page</i>	<i>description</i>	<i>package name</i>
10	mortar board	Education 1
11	mortar board and car	Education 1
14	dog	Artfolio 1
15	ships	Graphics & Symbols 1
16	ship	Graphics & Symbols 1
18	Washington	Four Seasons 1
20	all but center Washington	Four Seasons 1
20	center Washington	Personal Graphics
25	cat	Artfolio 1
27	dolls	Artfolio 1
29	boy	Seasonal
30	bird	Graphics & Symbols 1
31	bird	Graphics & Symbols 1
32	cat	Artfolio 1
35	right fish	Graphics & Symbols 1
36	flamingos	Artfolio 1
38	football player	Sports 1
40	chipmunk and elephant	Artfolio 1
41	bowler	Sports 1
42	bowler	Sports 1
43	United States	MacAtlas
44	United States	MacAtlas
48	left elephant	Artfolio 1
49	right fish	Sports 1
121	airplanes	Business 1
122	airplanes	Business 1
125	rhinoceros creature	Fanciful Animals
131	eye	Graphics & Symbols 1
158	hornet	Animals 2
160	hornet	Animals 2
167	page ornaments	Business Image
180	left cartoon	Holidays (CA)
180	center cartoon	Sports 1
180	right cartoon	Business 1

<i>page</i>	<i>description</i>	<i>package name</i>
197	left & right silhouettes	Four Seasons 1
197	two center silhouettes	Graphics & Symbols 1
225	Jefferson	Electronic Art Samples
225	robot arm	Business 1
225	soldier	Four Seasons 1
244	owls	Education 1
245	owls	Education 1
247	David	Personal Graphics
248	Davids	Personal Graphics
249	Davids	Personal Graphics
251	animals	Horror/Fantasy 1
252	rabbits	Holidays (PCQ)
253	left ghost	Graphics & Symbols 1
253	right ghost	Holidays (PCQ)
253	street lamp & castle	Graphics & Symbols 1
254	girls	Education 1
255	elves & barrel	Artfolio 1
256	elves & barrel	Artfolio 1
258	ocean liner	Electronic Art Samples
259	furniture	Artfolio 1
259	people	Graphics & Symbols 1
260	furniture	Artfolio 1
260	people	Graphics & Symbols 1
261	foliage border	Pictorial Nature Borders
261	liberty bell border	Holidays (PCQ)
261	bamboo border	Borders & Mortices 1
262	left border	Elaborate Antique Borders
262	woman	Business 1
263	border	Borders & Mortices 1
263	woman	Business 1
268	giraffes	Color Scans
271	women	Victorian Emblems
286	car	Electronic Art Samples
295	spaceships	Storyboards
303	Native American	Color Scans

Clip-art package vendors

<i>package name</i>	<i>product line</i>	<i>company</i>
Animals 2	MacMatbook	Electronic Publishers, Inc.
Artfolio 1	DeskTop Art	Dynamic Graphics, Inc.
Borders & Mortices 1	DeskTop Art	Dynamic Graphics, Inc.
Business 1	DeskTop Art	Dynamic Graphics, Inc.
Business Image	ClickArt	T/ Maker Company
Color Scans	<i>included with LaserPaint Color II application</i>	
Education 1	DeskTop Art	Dynamic Graphics, Inc.
Elaborate Antique Borders		Sunshine Graphics
Electronic Art Samples		Metro ImageBase, Inc.
Fanciful Animals		Sunshine Graphics
Four Seasons 1	DeskTop Art	Dynamic Graphics, Inc.
Graphics & Symbols 1	DeskTop Art	Dynamic Graphics, Inc.
Holidays (CA)	ClickArt	T/ Maker Company
Holidays (PCQ)		PC Quick-Art, Inc.
Horror/Fantasy 1		AAH Computer Graphics
MacAtlas		MicroMaps
Personal Graphics	ClickArt	T/ Maker Company
Pictorial Nature Borders		Sunshine Graphics
Seasonal	MacMatbook	Electronic Publishers, Inc.
Sports 1	DeskTop Art	Dynamic Graphics, Inc.
Storyboards	<i>included with GraphicWorks 1.1 application</i>	
Victorian Emblems		Sunshine Graphics

Vendor information

AAH Computer Graphics, PO Box 4508, Santa Clara, CA 95054

compatible with Macintosh computers only

(408) 980-7363

Dynamic Graphics, Inc., 6000 N. Forest Park Dr., Peoria, IL 61614

compatible with both Macintosh and DOS-based computers

(800) 255-8800

Electronic Publishers, Inc., 210 S. Marietta, Excelsior Springs, MO 64024

compatible with Macintosh computers only

(816) 637-7233

Metro ImageBase, Inc., 18623 Ventura Blvd., Suite 210, Tarzana, CA 91356

compatible with both Macintosh and DOS-based computers

(800) 843-3438

MicroMaps, PO Box 757, Lambertville, NJ 08530

compatible with Macintosh computers only

(609) 397-1611

PC Quick-Art, Inc., 394 S. Milledge Ave., Suite 252, Athens, GA 30606

compatible with DOS-based computers only

(800) 523-1796

Sunshine Graphics, PO Box 4351, Austin, TX 78765

compatible with Macintosh computers only

(512) 453-2334

T/Maker Company, 1973 Landings Dr., Mountain View, CA 94043

compatible with both Macintosh and DOS-based computers

(415) 962-0195

Index

A

AAH Computer Graphics 329

Aba Software 298

academic knowledge 23

additive primary model 68

Adobe Illustrator 305

Adobe Systems 141

Adone Systeme 296

advertisements 244

advertisements 261

airbrush tool 294, 302, 318, 321

Aldus FreeHand 305

“Align left” command 109

“Align middle” command 109, 193,
212

“Align right” command 109

alignment 109, 212

allGON tool 322

“Animate palette” command 297

Ann Arbor Softworks 292

anti-aliasing brush tool 297

appeal 11, 26, 28

guidelines 30

Apple Computer 300, 304

Apple fonts 106

Apple IIGS 317
 Apple menu 284, 290, 309
 appropriateness 26, 27
 arch feature 315
 arrow keys *See* cursor arrow keys
 arrowhead line cap 285, 321
 ArtGrabber 305
 artistic knowledge 8
 artistic style 18, 19, 250, 263
 consistency 30
 developing 21, 257
 examples of 20
 modifying 259
 Art RoundUp 305
 artwork,
 appealing 26
 appropriate 27
 as a commodity 243
 attributes of 28
 camera-ready 244
 cartoons 180
 combining with clip-art 257
 combining with photo-
 graphy 276
 copyrighted 307
 finished *See* final draft
 geometric 253
 library of 244
 logos 211
 object-oriented 283
 page ornaments 167
 reusing 15
 scanned 269
 serious-subject 225
 serious-subject 252
 silhouettes 197
 traditional 265
 warehouse of 251
 with important elements 43
 with incidental elements 44
 Ashton-Tate 293
 Athens screen font 106
 Atkinson, Bill 299
 audience,
 attention 262
 confusing 11
 gaining attention of 27, 44
 impressing 45, 57, 60, 67
 proximity to object 41
 relationship with artist 26
 auto-scrolling, lack of 315, 318
 autotracing feature 290, 321
 Avant Garde screen font 106

B

background 41, 55, 63, 146, 275, 285,
 319
 backspace key 105, 213
 “Balloon” command 316
 balloons 294
 behind 159
 bending 312, 319
 bezier curves 283, 288, 318, 321
 bird’s eye view 57
 bit-mapped type 103
 Bitstream 141
 black pigment 69, 70
 black-and-white graphics
 See monochrome graphics
 “Blend” command 275
 blending 275, 318, 321
 See also blurring
 block tool 287
 blue light 68
 blurring 298, 315

- color 24, 59, 68, 96, 100, 102, 181
 - graphics 73
 - models 68
 - monitor *See* monitor, color
 - painting application
 - See* painting application, color
 - palette 285, 297, 302, 307, 312, 315, 318
 - quick edit dialog box 315
 - scanning device 266, 301, 314
 - separations 70, 307, 312, 315, 319
 - shading 72
 - software 73
 - theory 68, 307
- “Color” icon 283
- ColorPrint 293
- ColorSep 307
- ComicWorks 295
- command key
 - drag at marquee corner 116, 159
 - drag at marquee side 213
 - plus < and > keys 292, 300
 - plus cursor arrow keys 285
 - plus option key
 - drag selected element 126
 - plus shift key
 - click with any tool 288
 - drag at marquee corner 182
 - plus 3 key 305
 - plus < and > keys 292, 300
 - with lasso 315
 - with pencil 130
 - plus shift and option keys
 - drag selected element 128
 - with eraser tool 305
 - with lasso 299, 315
 - with line tool 175
 - with marquee tool 114
 - with pencil 130, 175
 - with spraypaint tool 300
- commands 75, 133
 - basic 110
 - plug-in 320
- Commodore Amiga 317
- company logo *See* logo
- composition, 37
 - linear 38
- Computer Friends 308
- concept 9, 10, 27, 258
 - clarifying 11
- cone 311
- constant graphic element 212
- constraints 81
 - cloning 214
 - eraser 81
 - line tool 84
 - moving 218
 - pencil 81
 - polygon tool 85
 - shape tools 85
 - skewing 159
- contour feature 298, 315
- contracts 180
- contrasting pairs 71
- cookie cutter 138, 145, 151, 155, 288, 303
 - method 137
- “Copy” command 124, 183
- copy-protection 302

copying, 125, 183
 elements 111
 copyright laws 266
 Courier screen font 106
 covering a shape with another 113
 Cricket Draw 287
 Cricket Graph 287
 Cricket Paint 285, 287, 320
 Cricket Software 289
 cross-section 226
 cube 53, 287, 311, 320
 uses of 54
 cursor arrow keys 105, 285, 288, 321
 cursor coordinates 285, 288, 293,
 321
 curves 77
 custom shape tools 83
 customizable tools *See* macros
 "Cut" command 124
 cyan pigment 69, 70
 cylinder 311

D

dark shades 60, 78, 154, 234
 dBase 292
 delete key 105, 213
 deleting
 elements 213
 type 105
 Deluxe Paint II 317
 demagnify 130, 176
 "Demo" button 309
 Deneba Software 286
 density 94, 100, 235, 315
 depth 24, 51, 148, 226, 237, 272
 angles of 56
 directions of 53

dramatic 55
 perspective 51
 shades of 59
 within single object 61
 desk accessory 284, 290
 DeskDraw 290
 DeskPaint 290, 320
 DeskTop Art 328
 detail 46, 196, 239, 271
 intense 58
 diamonds 287, 300
 diffuse feature 298, 315, 321
 Digital Darkroom 267, 296
 dimension 51, 61
 directories 197
 disk buffer 267
 display type *See* type, display
 "Distort" command 123, 292
 distorting 123, 247
 dithering 267, 298, 315
 documents
 formal 180, 197, 211
 informal 179, 211
 legal 180
 serious 197
 dot-matrix printer
 See ImageWriter
 dot-matrix printer, color 70
 dots *See* pixels
 double-clicking
 eraser icon 80
 lasso icon 112
 marquee tool icon 115
 paintbrush icon 94, 181
 pattern icon 92, 152, 214
 plug-in tool icons 321
 double-spacing 109
 dragging a selected element 112

“Draw from center”
 command 168, 171
drawing 7
 a cartoon 179
 a face 184
 a hand 189
 a lamp 224
 a logo 210
 a page ornament 166
 a shadow 157
 a silhouette 196
 a sphere 62
 a voluminous object 62, 224
appealing artwork 29
as a process 12
curves 77
elegantly 30
final draft 14
for your audience 27
free-form lines 77
from a model 34
from a photograph 34
gradations 153
immense objects 45
in perspective 52
needs and restrictions 12
negative images 35, 121
shapes from center 169
single pixels 78, 194
sketching 13
three-dimensional objects 52
upside down 34
with a mouse 77
with a selected element 126
with incremental gray
 values 156
with transformation
 commands 190, 216

drawing layer 321
drawing speed 77, 99, 129
drawing technique 17, 19, 21, 243,
 269, 281
drawing theory 17, 19, 23, 243, 249,
 272
 complex 51
drop shadow *See* shadow, drop
duplication techniques 124
Dynamic Graphics 329

E

easels 294
editable type 104
Electronic Arts 319
electronic artwork *See* artwork
electronic clip-art *See* clip-art,
 electronic
electronic graphic process
 See graphic process
Electronic Publishers 329
electronic scans *See* scanned
 images
ellipse tool 84, 172, 183, 226
 filled 215
 with pattern 89, 215
ellipses 82
enclosed shapes 101, 113, 138, 191,
 201
enhancing reality 36, 37, 43, 47, 49
environment *See* object environ-
 ment *or* painting environment
EPS format 302, 306, 315
eraser 76, 79, 147, 169, 201, 290
 double-clicking icon 80
 lack of 312
eraser tool *See* eraser

erasing 271
 entire window 80
 in straight lines 81
 light source 233
 reference lines 54, 233
 sketch lines 169
 with eraser 79, 170, 201
 with line tool 145, 175
 with marquee tool 213
 with paintbrush 219
 with pencil 80, 205, 208
 with spraypaint tool 300

etching 316
 expert mode 307
 exporting 299

F

façade 55
 “fat-bits” 130, 175, 193, 201, 204,
 207, 270, 300
 features 46, 197
 “Fill perspective plane”
 command 319
 fill tool *See* paint can
 “Fill” command 119, 121, 143, 158,
 217
 filling
 an outline 102
 a shape with a custom
 interior 136, 249
 a solid area 102
 an enclosed shape 170, 101,
 202
 multiple elements 121
 partial elements 122
 shape with gradation 148
 solid area 206, 209

traced outline 135
 type 121
 with a pattern 143
 with custom
 interior 145

film 272
 film recorder 317
 final draft 9, 12, 14, 27, 239, 258, 270
 finder 284
 finished graphic *See* final draft
 first impressions 26, 31
 fit-in-window view size *See* view
 size, fit-in-window
 flat-bed scanners 266
 “Flip horizontal” command 115,
 229, 248
 “Flip vertical” command 115, 159,
 182, 190
 flipping 115, 247, 256, 274
 optional 159
 fluorescence 71
 flush left type 109
 flush right type 109
 focus 58
 font 106, 212
 commands 103
 Font/DA Mover 107, 284, 290
 foreground 41, 55, 285
 form 24, 32, 65, 157, 247, 272
 accurate 35
 basic 33, 38, 64, 167, 181, 200,
 230
 consistent flow of 37
 human 196
 naturalistic 36
 recording 34
 simplification of 200
 stylizing 36

formats *See* image-saving formats
four-color separations 70
“Free rotate” command 122, 292
freehand shapes 83
freehand tool 85
 filled 202, 270
 with patterns 89
FreshPaint feature 287
FullPaint 281, 292, 305
FullWrite 292

G

Gallery 317
Geneva screen font 106
geometric objects 36, 64, 82, 253
globe *See* sphere
grabber hand 130, 132, 176
 lack of 312
grabber tool *See* grabber hand
gradation 64, 66, 148, 151
 automated 288, 297, 312, 315,
 319
 color 71
 commands 148
 demos 297
 swash 149
 symmetrical 65
graphic environment 57
graphic process 9, 21
graphics *See* artwork
GraphicWorks 294
GraphistPaint B&W 296
GraphistPaint II 296
gray scale scanning device 266, 301
gray values, 96, 100, 102, 136, 143,
 148, 155, 181, 270
 examples of 90

incremental 152, 155, 233, 288,
 309

green light 68
ground level *See* surface or horizon

H

half-toning 268
hand tool *See* grabber hand
handles 117, 122, 287
hard drive 284, 290, 296, 301, 314
haze 59
Helvetica screen font 106
hexagons 287, 300
highlights 61
hints and tips 133, 248
horizon 52, 159
 extending object into 55
hyper polygon tool 287
HyperCard 282, 287, 299, 304, 320

I

IBM PC 292, 317
illumination *See* light source
“Illumination” command 307
Image Studio 267, 296
image-saving formats 267
ImageWriter 178, 194, 209, 221, 240
immensity 45
important graphic elements 43
importing 299
in back of *See* behind
in front of 112, 159
incidental graphic elements 44
interaction 255
“Invert” command 119, 121, 145,
 146, 218, 248



Macintosh 512K 292, 294, 309
 Macintosh Plus 68, 105, 284, 287,
 290, 293, 296, 299, 301, 311, 317,
 320
 Macintosh SE 68, 284, 287, 290, 296,
 299, 301, 311, 317, 320
 MacPaint 281, 292, 299, 304, 317,
 320
 format 267, 284, 287, 290, 292,
 294, 297, 299, 302, 304,
 306, 309, 315, 318, 320
 lack of support 312
 macros 284, 288, 320
 magenta pigment 69, 70
 magnified view size *See* view size,
 magnified
 magnify 130
 magnifying glass *See* zoom tool
 manuals 197
 marquee tool 111, 114, 146, 159, 182,
 213, 226, 287, 321
 double-clicking icon 115
 marquee
 corner handle 117, 122
 loosely 216
 shrinking 115
 lack of 321
 masking 297, 302, 312, 315, 318
 masking tape tool 309
 MasterJuggler 284, 290
 medium shades 235
 Metro ImageBase 329
 MicroIllusions 313
 MicroMaps 329
 MindScape 295
 mixing bowl tool 309
 Mobile screen font 106
 models 34
 Modern Artist 306, 317
 Monaco screen font 106
 monitor
 color 68, 73, 296, 301, 306, 311,
 314, 317, 320
 incompatibility 293, 295
 gray scale 306, 311
 monochrome 68, 269, 310
 monochrome graphics 68, 73, 267
 “Monochrome” icon 283
 monochrome monitors
 See monitors, monochrome
 monochrome painting applications
 See painting applications,
 monochrome
 monochrome scanning 266
 “Mosaic” command 315
 mouse 17, 77, 186
 mouse button 75
 “Mouse crawl” option 293
 “MouseSpot” window 293
 moving
 elements 111, 112
 page within window 132
 Multifinder 284
 multigon tool 321

N

neutral pairs 71
 New Century Schoolbook screen
 font 106
 New York screen font 106
 newsletters 49, 166
 newspapers 244, 268
 “None” button 97
 normal view size *See* view size,
 normal

NuEquation 310

NuPaint 309

O

object environment 63, 67, 157, 238

object-oriented 283, 285, 290, 302

octagons 287, 300

“OK” button 92, 97, 181, 215

opacity 112, 114, 299

optic sensor 266

option key

drag page in window 132, 176

drag selected bar 153

drag selected element 126,
137, 157, 182, 184, 190

drag selected line 134

drag selected swash 150

plus command key

drag selected ele-
ment 126

plus cursor arrow
keys 285

plus shift key

drag selected ele-
ment 213

plus shift and command keys

drag selected ele-
ment 128

with rectangle tool 168

origin of light *See* light source

ornament *See* page ornament

outline 32, 85, 112, 119, 139, 158,

209, 239

accurate 35

broken 101, 113, 138, 143, 201

closing off 191, 209

filled 89

overlay modes 283, 294, 295, 297,

305

P

page ornament

comparison 179, 197

definition 166

examples, of 167

purpose of 166

simplicity 167, 178

paint bucket *See* paint can

paint can 93, 101, 135, 160, 170, 201,
205, 307

flood and boundary fill
tools 312

paint can tool *See* paint can

paint layer 321

paintbrush 93, 155, 181, 271, 290,
307, 318

double-clicking icon 94, 181

with brush mirrors 97

with pattern 96, 185, 188

paintbrush tool *See* paintbrush

painting application 75

color 59, 267, 276, 296, 301,
306., 311, 314, 317

monochrome 267, 273, 284,
287, 290, 292, 294, 296,

299, 301, 309, 311, 317,
320

painting environment 75, 294

basic 132

Palatino screen font 106

palettes *See* toolbox, pattern

palette, *or* color palette

panels 294

Pantone color formula guide 315

Pantone color matching system 70,
 314
 "Paste" command 124, 189, 297
 pasting 125, 189
 patterns 82, 96, 100, 102, 136, 143,
 181, 270, 312
 altering 90
 double-clicking icons 92, 152,
 214
 editing 92, 152, 214, 233
 examples of 91
 garish 89, 100, 187
 gray values *See* gray values
 line 146, 234
 custom 288
 multi-colored tiles 316
 pattern edit dialog box 92, 214, 297
 pattern palette 91, 233, 304, 312
 pattern sizes 309
 PC *See* IBM PC
 PC Quick-Art 329
 pencil 76, 85, 138, 175, 185, 191, 201,
 203, 219, 229, 256, 270, 297, 309,
 318
 in "fat-bits" 130
 lack of 312
 with brush mirrors 98
 pencil tool *See* pencil
 "Pen" patterns 175
 pen tool 288
 personal artistic style *See* artistic
 style
 perspective 51, 52, 226, 287, 312,
 315, 320
 customizable 318
 perspective box 54
 "Perspective" command 122, 292
 photocopiers 266
 photographic process 272
 photographs 34, 269
 photo imagesetter 301, 314
 Photon Paint 311
 PICT format 284, 287, 290, 294,
 297, 302, 306, 309, 311, 315, 318,
 320
 pigmentation 69
 "Pixelize" command 311
 PixelPaint 281, 296, 306, 314, 317
 pixels 134, 152, 174, 201, 267, 270,
 275, 285, 288, 309, 311, 315, 321
 clicking on and off 78, 194
 creating 78
 deleting 79
 in "fat-bits" 131
 in pattern dialog 92, 214
 PixelScan 314
 plain type style 107, 193
 plug-in tools 320
 double-clicking icons 321
 points, unit of measure 108
 polygon tool 85, 198
 filled 270
 special 287, 300, 321, 322
 with patterns 89
 polygons 83
 portraits 225
 PosterMaker 294
 PostScript 285, 290, 301
 PostScript routines 285
 practical knowledge 23, 75
 presentation 24, 26, 32
 guidelines 30
 primary colors 68
 printing 12, 267, 307, 312
 color 70
 layers 285

process color printing 70
product illustrations 225
professional presentation
 See presentation
proportion 24, 51, 227
 altering 47
 determining 46
 exaggerating 49
 forcing visual relationships 47, 50
proportional relationships 47, 48
proximity 41
publications *See* documents
purpose 9, 10, 258

Q

QuickDraw 285, 299

R

random access memory
 (RAM) 267, 286, 291, 302
razor tool 309
realism 32, 57, 59, 60, 66, 148, 155,
 157, 196, 224, 253, 272
rectangle tool 84, 138, 168, 212
 filled 171
 with pattern 89
rectangle with rounded corners tool
 See rounded corner tool
rectangles 82
 with rounded corners 82
red light 68
reference lines 52, 62, 231
reference points 52
reflected light 67, 237
reflecting *See* flipping

relaxing elements 134, 220
relative size *See* scale
relative sizing, details 48
replacing an element 124
reports 180, 197
ResEdit 321
return key 105, 193
reusing a graphic 15
RGB color model 68, 312
RIFF (scanned image-saving
 format) 297
“Rotate” command 115, 190, 248
rotating 115, 247, 256, 274
 by degrees 307
 freely 123
rounded corner tool 84
rPIC format 306

S

San Francisco screen font 106
saving 9, 15, 178, 194, 209, 221, 240
 layers 285
scale 24, 39, 46
“Scale” command 117
scale, similar 40
scaling 115, 159, 182, 226, 247, 274,
 287, 312
 by percentage 304
 for drama 39, 45
 to indicate distance 39, 41
 to indicate importance 39, 43
 using Clipboard 124
scanned images 265
 art/photo hybrids 276
 artwork 269, 270
 photographs 269, 272
 refining 270, 272

- scanning device 265, 269, 275
 - for 35 mm slides 301
 - process 266
- scissors tool 318
- Scrapbook 290
- screen fonts 107, 142, 318
- screen font sizes 108
- screen pixel *See* pixel
- screen shot 305
- SE *See* Macintosh SE
- selecting
 - contents of entire window 112
 - entire window 115
 - existing element 111
 - multiple elements 121
 - partial element 112, 122, 184
 - tools 76
 - type 121
 - with lasso 111
- selection tool *See* lasso or marquee tool
- “Set pixelization” command 311
- shades 78
- shades of gray 59
- shade tool 307
- shading 64, 231, 239
 - color 72
 - with gray values 156
 - with line patterns 234
- shadow type style 107
- shadows 61, 226, 236
 - adding to image 157, 249
 - automated 309, 315
 - drop 316
- shape tools 82
 - filled 83, 89, 270
 - with brush mirrors 98
- shapes
 - calligraphic 87
 - closing off 191, 209
 - filling 101
 - free-form 83
 - geometric 82
 - with break in outline 101, 113, 138
 - with custom interiors 136, 249
 - with enclosed interiors 101, 113, 138
 - with gradated interiors 148
 - with opaque interiors 112, 140
 - with transparent interiors 112, 140
- sheet-feed scanners 266
- shift key
 - drag selected element 177
 - plus command key
 - click with any tool 288
 - drag at marquee corner 182
 - plus 3 key 305
 - plus < and > keys 292, 300
 - with lasso 315
 - with pencil 130
 - plus option key
 - drag selected element 213
 - with “Perspective” command 123
 - with “Skew” command 122, 159
 - with ellipse tool 173
 - with eraser 81

- with line tool 84, 168
- with pencil 81
- with polygon tool 85
- with shape tools 85
- with spraypaint tool 149
- silhouette
 - comparison 240
 - examples of 197
 - purposes of 197
 - simplification of form 200
 - versatility 196
- Silicon Beach Software 267, 300, 322
- similarizing objects 50
- single-spacing 109
- size relationships 39, 40, 45
- sizing 30
- sketch lines *See* reference lines
- sketch
 - complex 226
 - geometric 169, 198
 - softening 203
- sketching 9, 19, 64, 167, 244
 - examples of 13
 - from a model 34
 - purposes of 13
 - reference lines 52, 231
 - shading 231, 234
 - shadows 232
 - with ellipse tool 198
 - with line tool 167
 - with polygon tool 199
 - with rectangle tool 168
 - with the pencil 81
- “Skew” command 122, 292
- skewing 123, 159, 247
- “Slant” command 122
- slanting *See* skewing
- smooth lines *See* lines, smooth
- smoothing 298
- smoothing 315
- smoothing 318
- snapshot feature 305
- software tools *See* tools
- Souvenir screen font 141
- space, relationship with
 - graphics 30
- spacebar 292
 - drag page in window 132, 176
- spatter cap option 302
- special effects 115, 122, 133, 210, 224, 249, 276, 298, 311, 316
- sphere 62, 296, 311
- spherization 297
- spiograph images 288
- spot color printing 70
- spraypaint tool 93, 99, 149, 155, 207, 237, 290, 297, 307
 - plug-in 321
 - with brush mirrors 98
 - with patterns 100
- squares 82
- stack 287, 299, 320
- stain tool 307
- “Stamp object” command 288
- Startup Screen format 304, 309, 315, 320
- statements 180
- stationary elements 112
- stencil 296
- straight lines 80, 82, 84
- “Stretch” command 117, 182, 213
- stretching *See* scaling
- Studio/1 317
- Studio/8 281, 296, 316, 317
- Studio/32 317

style *See* artistic style *or* type style
stylization 36, 253
subtractive primary model 69
successful drawing technique
 See drawing technique
Suitcase 284, 290
sunglasses tool 307
Sunshine Graphics 329
“SuperBits” feature 321
SuperCard 300
SuperMac Software 316
SuperPaint 300, 320
surface 62, 159, 172, 238
Symbol screen font 106
symmetry 64, 98, 229
System file 107, 142, 147, 284, 290

T

tagged image file format
 (TIFF) 267, 284, 287, 290, 294,
 297, 302, 315, 318
 lack of support 307, 312, 321
“Take snapshot” command 305
technical support 292, 302, 320
technique *See* drawing technique
text *See* type
text entry cursor 105
text tool 103, 193, 212
textural effects 103
textural interior 136, 145, 151, 249
textural type 147
texture tool 288
texture tool dialog box 288
theoretical tools *See* drawing
 theory
theory *See* drawing theory
thermal printer 317

three-dimension tool 307
three-dimensional box *See* cube
three dimensions 51
 translating to paper 159
TIFF *See* tagged image file format
 (TIFF)
tiles 315
Times screen font 106, 142
 using 193, 212
tint 72
tinting 318
T/Maker 329
tool icons, editable 288, 302
tool palette *See* toolbox
toolbox 17, 76, 292, 304, 312
tools 17, 19, 75, 133, 269
 custom *See* macros
 plug-in 320
“Trace edges” command 118, 135,
 216
tracing edges 118, 247
tracing, with a PostScript path *See*
 autotracing feature
transformation commands 290,
 292, 297, 318
transformations 115, 212, 247, 249
 advanced 122
 irregular 124
transforming elements 111
transparency 112, 295, 297, 299, 313
triangles 287, 300
trowel tool 309
twisting 312
type 103, 141
 as a graphic element 104, 141,
 213
 attributes of 28
 body copy 110

deleting 105
display 110, 144
entering 105, 193, 212
inverted 146
jagged 108, 142, 145
large 144
on a curve 302
surrounding a graphic 10, 28
with break in outline 143
with custom fill 145
type size 108, 193, 212, 300
type style 107, 212
type tool *See* text tool
typeface 106, 212
typesetter *See* photo imagesetter

U

underline type style 107
“Undo” command 186, 188, 199,
202, 215, 302, 311
undrawing 35, 80, 205, 208

V

Venice screen font 106
video card
8-bit 296, 301, 306, 314, 317
24-bit 301, 317
32-bit 317
video frame-grabbing card 296
video images 298
view size 129, 304
demagnified 130
fit-in-window 131
magnified 130, 175, 203, 219
multiple windows 312
normal 131, 176, 233

viewer *See* audience
visual themes 10, 46
volume 24, 61, 226, 272
voluminous object 64
versatility 225, 240

W

warping 316
water drop tool 297
weight *See* line weight
components *See* line weight,
components
“Wet canvas” command 307
word-processor 103, 110
worm’s eye view 57

Y

yellow pigment 69, 70

Z

Zapf Chancery screen font 106
Zapf Dingbats screen font 106
Zedcor 291
zoom tools 130, 175

Acknowledgements

The following people encouraged another idea to run away from home.

Thanks to Bill Gladstone and Susan Glinert for engaging contract sports; to Kathi Townes and Carolyn MacPhail for writing all the wordly wrongs; to Scott Harmon for churning out the fonts; to Mark Bradin, Brian Griswold, Susan Janow, Tom Midgely, and Eric Patzer for holding down the fort. And a big thanks to Craig Danuloff for getting in my way so many times that it finally made sense.

For product acquisition, thanks to Alan Parks at Deneba, Sally Dunn at Cricket, Isaac Goff at LaserWare, Sharon McBride at Computer Friends, Susie Hegg at NuEquation, Curtis North at MicroIllusions, Kathy Williams and Nancy Duenkel at SuperMac, Nicole Noland at Electronic Arts, and Stuart Henigson and Caroline Twitchell at Silicon Beach. Also thanks to MSC Technologies and Laurin at Kurta Corp. for their respective ADB input devices.

This makes it five for five, gentlemen—R.D., S.R., J.G., A.E., and J.M.

Thank you, too, to the lovely Elizabeth Pheasant for waiting ten minutes multiplied by every day in our marriage. And to Dave and Ronda for making me look timely.

Colophon

Painting on the Macintosh was outlined in MORE 1.1 and written in Microsoft Word 3.2 and 4.0.

Graphics were created using MacPaint 2.0, SuperPaint 1.1 and 2.0, Canvas 2.0, and Studio/8 1.0. Diagrams in Chapters 1 and 2 were partially created in Adobe Illustrator 88 1.6. In combination with DeskPaint 2.0, Capture was used to create screen shots displayed in Chapters 3 through 7. Some scans in Chapter 9 were enhanced using Image Studio 1.5. And each figure in Chapter 10 was created in the featured application.

The front cover was created using PixelPaint 2.0 and Studio/8, and digitally separated at 175 lines-per-inch by ImageSet Corp.

Pages were composed in Aldus PageMaker 3.01. Art RoundUp 1.2 was used to import many paint files; The Clipper 1.0 was used to scale them. Body copy was set in LaserPerfect Ambo and Ambo Italic, both from NeoScribe International. Em dashes and question marks are in Times. Chapter titles were created in Campanile from Casady & Greene's Fluent Laser Fonts; chapter numbers are in Flourish by Judy Sutcliffe, available through the Electric Typographer. The cover features Campanile as well as ITC Eras Book and ITC Eras Demibold from the Adobe Typeface Library.

MasterJuggler 1.0 was used for font management; Set Paths 1.3 was used to manage networked printer fonts and LaserStatus 3.0.3 was used for manual downloading. Final camera-ready pages were imaged at 1270 dots-per-inch from a Linotronic 100P by Publishing Resources Inc.

The following are trademarks and registered trademarks that were used throughout this book—succeeded by the controlling companies: Adobe Illustrator 88, Adobe Type Library, PostScript—Adobe Systems Inc.; Aldus FreeHand, Aldus PageMaker—Aldus Corporation; Amiga—Comodote Business Machines Inc.; Apple IIGS, Finder, HyperCard, ImageWriter, LaserWriter, Macintosh, MultiFinder, QuickDraw—Apple Computer, Inc.; Art RoundUp—Dubl-Click Software; B/W Photon Paint, Photon Paint—MicroIllusions; Canvas, Canvas DA—Deneba Software; ClickArt—T/Maker Company; ColorSep, Modern Artist—Computer Friends; ComicWorks, GraphicWorks, PosterMaker—Mindscape, Inc.; Cricket Draw, Cricket Graph, Cricket Paint, FreshPaint—Cricket Software; dBase, FullPaint, FullWrite—Ashton-Tate; DeluxePaint, Gallery, Studio/8—Electronic Arts; DeskDraw, DeskPaint—Zedcor, Inc.; Desk Top Art—Dynamic Graphics, Inc.; Digital Darkroom, SuperCard, SuperPaint—Silicon Beach Software; GraphistPaint II, GraphistPaint B&W—Adone Systeme; Helvetica, Palatino, Times—Allied Corporation; IBM PC—International Business Machines; ITC Avant Garde Gothic, ITC Bookman, ITC Eras, ITC Zapf Chancery, ITC Zapf Dingbats—International Typeface Corporation; ImageBase—Metro Creative Graphics, Inc.; Image Studio—Letraset USA; LaserPaint, LaserPaint Color II—LaserWare, Inc.; LaserStatus—CE Software, Inc.; Linotronic—Linotype Company; MacAtlas—MicroMaps; MacMatbook—Electronic Publishers, Inc.; MasterJuggler—AlSoft, Inc.; NuPaint—NuEquations, Inc.; Pantone, Pantone Matching System—Pantone, Inc.; PC Quick-Art—PC Quick-Art, Inc.; PixelPaint, PixelScan—SuperMac Software; Suitcase—Supply Software; Set Paths—Paul F. Snively; The Clipper—Solutions International.

What's your opinion?

At Publishing Resources Inc., we are interested in helping you to better understand and utilize your computer and computer software. This means that we not only want to produce quality books, but that we also strive to make our existing books better.

As a reader, we value your criticism. If you find any inaccuracies, typographical or informational, or have any suggestions for future editions, we encourage you to write us at the address at the bottom of this page. Perhaps you have a tip you would like to share, or an opinion regarding an application covered in this book. Your letter will be very much appreciated.

About the Author



Deke McClelland provides training and consulting services through Publishing Resources Inc. His previous work, along with co-author Craig Danuloff, includes *Desktop Publishing Type & Graphics*, *Mastering Aldus FreeHand*, *Mastering Adobe Illustrator 88*, and *The PageMaker Companion*, Macintosh and PC versions.

**PUBLISHING
RESOURCES**
INCORPORATED

711 Walnut Street, Suite 200
Boulder, Colorado 80302
(303) 442-8221

Also available from Dow Jones-Irwin

Mastering Aldus FreeHand

Deke McClelland and Craig Danuloff

ISBN 1-55623-118-0

DJI # 15-2757-01

Mastering Adobe Illustrator 88

Deke McClelland and Craig Danuloff

ISBN 1-55623-157-1

DJI # 15-2861-01

The PageMaker Companion Macintosh 3.0 Edition

Deke McClelland and Craig Danuloff

ISBN 1-55623-190-3

DJI # 15-2945-01

The PageMaker Companion PC 3.0 Edition

Deke McClelland and Craig Danuloff

ISBN 1-55623-189-X

DJI # 15-2944-01

Purchase these titles from your local bookseller

or order directly from Dow Jones-Irwin by calling **1-800-634-3966**



ng on the Macintosh!

A NON-ARTISTS GUIDE TO DRAWING WITH POPULAR PAINTING SOFTWARE

Do you wish that you could create better graphics with your bit-map drawing software? Well now you can. This book teaches you how an artist thinks, the techniques that an artist employs, and inside tricks for use with the familiar tools available in all painting software. In later chapters, sample projects let you practice what you learn.

Understand the graphic process. Learn to develop the concept of your graphics, sketch your initial ideas, create final drafts, and save your work for future use.



Understand drawing theory. Learn how you can improve your graphics by mastering professional presentation, realistic drawing form, object scaling, proportion, depth perspective, volume, and color.

Understand the tools of bit-mapped software. Learn how to effectively use the pencil, eraser, line tools, shape tools, spraypaint tool, paint can, fill patterns, brush shapes, text tool, transformation commands, and other special effects features. Plus the most important painting tips, tricks, and secrets.



Sample projects bring it all together. Follow along as we create a graphic icon, a simple cartoon, a silhouette, a company logo, and a realistic voluminous object. Learn how to spruce up your clip art, and make the most of your own scanned artwork and photographs.

Comprehensive review of all fifteen paint applications available for the Mac. Complete descriptions include hardware requirements, distinguishing features, negative attributes, and a "Who needs this software" summary.



ISBN 1-55623-265-9



9 781556 232657

15-3108-01